

MEDICON eG · GERMANY · 47° 57' 31.4" N · 8° 46' 58.6" E



MEDICON

instruments

OMF - SURGERY

Mund-, Kiefer- und Gesichtschirurgie
Oral and Maxillofacial Surgery
Cirugía oral y maxilofacial
Chirurgie maxillo-faciale
Chirurgia maxillo-facciale

medicon[®]



Not all products illustrated in this documentation are available for sale in all countries.
Please contact your local distributor for more information.

MEDICON

instruments

OMF - SURGERY

Instrumente für die Mund-, Kiefer- und Gesichtschirurgie
Instruments for Oral and Maxillofacial Surgery
Instrumentos para cirugía oral y maxilofacial
Instruments pour la chirurgie maxillo-faciale
Strumenti per la chirurgia maxillo-facciale

Die Entwicklung, Herstellung und der Vertrieb chirurgischer Instrumente und Implantate haben bei uns eine jahrzehntelange Tradition. In unseren 11 Mitgliedsbetrieben werden über 35.000 verschiedene Artikel für die Humanmedizin gefertigt.

Wir haben es uns zur Aufgabe gemacht, Chirurgen und OP-Personal der Mund-, Kiefer- und Gesichtschirurgie mit innovativen Implantaten und Instrumenten zu versorgen, welche die Fortschritte der operativen Behandlung unterstützen.

Mit Verantwortung und Engagement bündeln wir unsere Aktivitäten in drei Kernkompetenzen.

Our company has decades of experience in developing, manufacturing and selling surgical instruments and implants. Our 11 member companies produce over 35,000 different items for human medicine.

We have made it our goal to supply surgeons and surgical personnel in Oral and Maxillofacial Surgery with innovative implants and instruments, which support the progress in surgical treatment.

With responsibility and commitment, we focus our activities on three core competences.

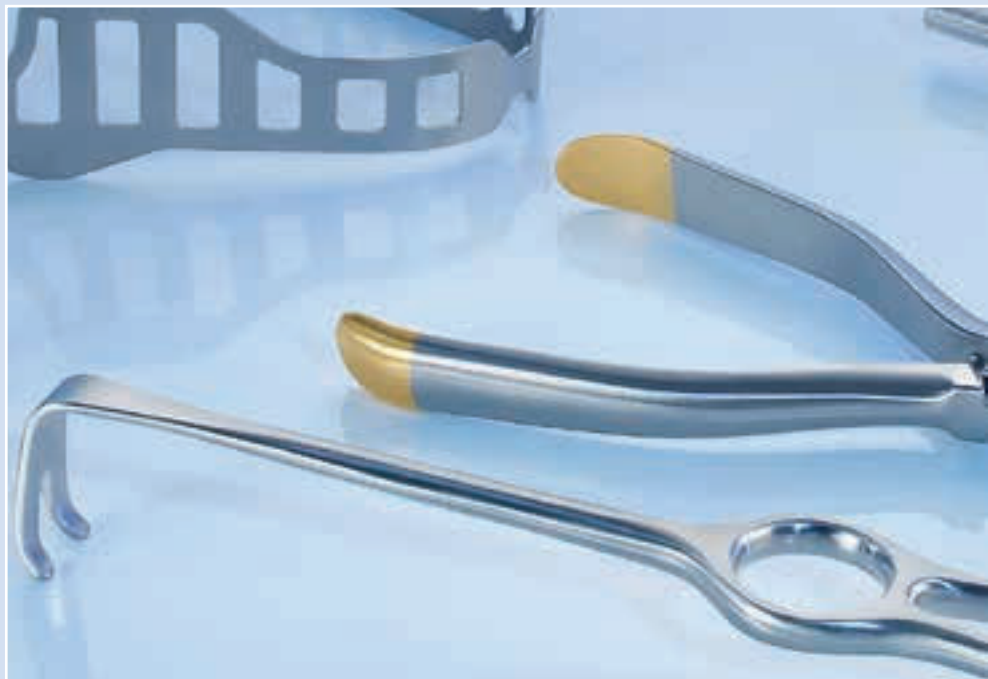

El desarrollo, la fabricación y la distribución de implantes e instrumentos quirúrgicos representa para nosotros décadas de tradición. En los talleres de nuestros 11 socios se fabrican más de 35.000 artículos diferentes para la medicina humana.

Nos hemos propuesto la tarea de abastecer a cirujanos y a personal de quirófano de la cirugía oral y maxilofacial con innovadores implantes e instrumentos que respaldan el progreso del tratamiento quirúrgico.

Con responsabilidad y compromiso, centramos nuestra actividad en tres competencias básicas.

Le développement, la fabrication et la vente d'instruments chirurgicaux et d'implants ont une tradition longue depuis plusieurs décennies chez Medicon.

Nos 11 entreprises membres produisent plus de 35.000 articles différents dans le secteur de la médecine.

Nous nous sommes fixés pour objectif de fournir aux chirurgiens et au personnel opératoire actifs dans le secteur de la chirurgie maxillo-faciale des implants et instruments novateurs suivant les progrès du traitement opératoire.

Avec conscience et engagement, nous regroupons nos activités dans trois compétences majeures.

Lo sviluppo, la produzione e la distribuzione di strumenti chirurgici e impianti hanno da noi una tradizione pluridecennale.

Nelle nostre 11 aziende associate, vengono fabbricati oltre 35.000 diversi articoli per la medicina umana.

Il compito che ci siamo proposti è quello di fornire ai chirurghi e al personale di sala operatoria di chirurgia maxillo-facciale impianti e strumenti innovativi che supportano i progressi del trattamento chirurgico.

Con responsabilità e impegno riuniamo le nostre attività in tre competenze di base.



CMF

Das Kompetenzfeld **CMF** kombiniert unsere modular aufgebauten Systeme für die Distraction und Osteosynthese in der kranio-maxillo-fazialen Chirurgie mit anwendungs-optimierten Lösungen und intuitiver Bedienbarkeit zu einem zukunfts-orientierten Konzept.

The competence field **CMF** combines our modular systems for distraction and osteosynthesis in Cranio-Maxillofacial surgery with application-optimised solutions and intuitive operation to produce a forward-looking concept.

SURGICAL

Das Kompetenzfeld **SURGICAL** vernetzt unsere mehr als siebzigjährige Erfahrung als Medizintechnik-Unternehmen mit weit über 35.000 Produkten, die nahezu alle Indikationen der einzelnen chirurgischen Fachbereiche abdecken.

The competence field **SURGICAL** links our more than seventy years of experience as a medical technology company with over 35,000 products covering nearly all indications of the individual surgical specialty fields.

NEURO+SPINE

Das Kompetenzfeld **NEURO+SPINE** konzentriert sich auf unser Produkt-Portfolio von qualitativ hochwertigen Instrumenten und innovativen Implantaten für die Neurochirurgie mit dem Fokus der produktbezogenen Spezialisierung als Grundlage einer transparenten Vertriebsstrategie.

The competence field **NEURO+SPINE** focuses on our product portfolio of high-quality instruments and innovative implants for Neurosurgery with the main emphasis on product-related specialisation as a basis for a transparent sales strategy.

El área de especialización **CMF** combina nuestro sistema modular para la distensión y osteosíntesis en la cirugía cráneo-maxilofacial con soluciones orientadas a la aplicación y un manejo intuitivo para desarrollar un concepto enfocado hacia el futuro.

Le domaine de compétence **CMF** associe nos systèmes modulaires utilisés pour la distraction et ostéosynthèse en chirurgie crânio-maxillo-faciale à des solutions d'application optimisées et à une manipulation intuitive. Le résultat: Un concept d'avenir.

L'area di competenza **CMF** associa i nostri sistemi componibili per la distrazione e la osteosíntesi nella chirurgia cranio-maxillo-facciale a soluzioni ottimizzate nell'applicazione e manipolazione intuitiva, per un concetto orientato al futuro.

El área de especialización **SURGICAL** fusiona nuestros más de 70 años de experiencia como empresa de tecnología médica con más de 35.000 productos que cubren casi todas las indicaciones de cada una de las disciplinas quirúrgicas.

Le domaine de compétence **SURGICAL** allie notre expérience de plus de 70 années dans le secteur des techniques médicales à plus de 35.000 produits, couvrant la quasi-totalité des indications de la chirurgie actuelle.

L'area di competenza **SURGICAL** collega la nostra ultrasettantennale esperienza aziendale nel campo della tecnica medica con oltre 35.000 prodotti che soddisfano quasi tutte le indicazioni delle singole aree di specializzazione chirurgiche.

El área de especialización **NEURO+SPINE** se centra en nuestra cartera de productos de instrumentos de alta calidad e implantes innovadores para la neurocirugía considerando la especialización relacionada con los productos como base de una estrategia de ventas transparente.

Le domaine de compétence **NEURO+SPINE** se concentre sur notre gamme d'instruments de grande qualité et d'implants novateurs pour la neurochirurgie, avec une spécialisation sur les produits comme base d'une stratégie de vente transparente.

L'area di competenza **NEURO+SPINE** si concentra sul nostro portfolio di strumenti di alta qualità e impianti innovativi per la neurochirurgia, e si propone come focus la specializzazione del prodotto come base di una trasparente strategia di distribuzione.

**Wir setzen auf Farben.
We rely on colours.
Apostamos por el colores.
Nous mettons l'accent sur les couleurs.
Puntiamo sul colori.**



COLOR[®]
YOUR TOOLS!

medicon®



Mit unserem neuen Service "COLOR YOUR TOOLS" bieten wir die Möglichkeit, fast alle chirurgischen Standard-Instrumente komplett oder partiell in einen der sechs definierten Farbtöne zu kolorieren. Diese individuelle Farbgebung verleiht ihren Instrumenten nicht nur eine unverwechselbare Note sondern auch einen speziellen Vorteil bei der Zuordnung und Identifikation.

With our new service "COLOR YOUR TOOLS" we offer nearly all surgical standard instruments fully or partially coloured in six different tones. These individual colours not only give your instruments a unique look but also provide an advantage when distinguishing and identifying them.

Con nuestro nuevo servicio "COLOR YOUR TOOLS", ofrecemos la posibilidad de dar a casi todos los instrumentos quirúrgicos estándar una coloración completa o parcial en uno de los seis colores definidos. Esta coloración individual no solo confiere a sus instrumentos un toque inconfundible, sino también una utilidad especial en su clasificación e identificación.

Grâce à notre nouveau service "COLOR YOUR TOOLS", vous avez la possibilité de colorer, en tout ou partie, l'ensemble de nos instruments chirurgicaux standard dans l'un des six coloris pré-définis. Cette coloration individuelle confère non seulement une touche personnelle et unique à vos instruments, mais permet également de mieux les trier et les identifier.

Con il nostro nuovo servizio "COLOR YOUR TOOLS", vi offriamo la possibilità di colorare completamente o parzialmente quasi tutti gli strumenti chirurgici standard in una delle sei tonalità disponibili. Questa colorazione personalizzata conferisce ai vostri strumenti non solo un tocco inconfondibile, ma anche un vantaggio specifico nell'associazione e nell'identificazione.

www.coloryourtools.de

Weitere Informationen finden Sie in unserem Prospekt und auf unserer Webseite.
For further information, please refer to our special brochure and on our homepage.
Informaciones adicionales se encuentran en nuestro folleto y en nuestra página web.
Vous trouverez d'autres informations dans notre prospectus et sur notre page d'accueil.
Altri informazioni si trovano nel nostro depliant e sul nostro sito.

Der Ihnen vorliegende Katalog "Instrumente für die Mund-, Kiefer- und Gesichtschirurgie" bleibt unser Eigentum, auch wenn eine Leih- oder Schutzgebühr bezahlt wurde. Er darf nur zum Einkauf und Vertrieb der darin beschriebenen MEDICON-Produkte durch den dazu autorisierten Fachhandel und für die Bedarfsbeschaffung durch den jeweiligen Anwender verwendet werden. Seine Verwendung gegen unsere Interessen berechtigt uns zur sofortigen Rückforderung und möglichen weitergehenden Maßnahmen. Ohne unsere ausdrückliche, schriftliche Genehmigung darf dieser Katalog weder im Gesamten noch auszugsweise nachgedruckt oder kopiert werden.

This present "Instruments for Oral and Maxillofacial Surgery" catalogue remains exclusively our property even if a lending fee or charge has been paid for it. It shall only be used by specialized dealers to buy and sell MEDICON products or by individual users to meet their own requirements. In case of misuse we are entitled to recall the catalogue immediately and to take further steps if necessary. It is not allowed to reprint or copy this catalogue in whole or in parts without our written permission.

El presente catálogo "Instrumentos para cirugía oral y maxilofacial" sigue siendo nuestra propiedad aunque se ha pagado ciertos derechos de préstamo. Debe servir a los revendedores autorizados del ramo exclusivamente para la compra y la distribución de los productos MEDICON que describe, y a los especialistas y usuarios particulares para escoger los instrumentos necesarios para su abastecimiento. Su empleo abusivo en perjuicio de nuestros intereses, nos da derecho a exigir su devolución inmediata y a tomar todas las medidas ulteriores que juzguemos necesarias. Sin nuestro permiso expreso por escrito es prohibido reproducir o copiar este catálogo, tanto en su totalidad como en extractos.

Le présent catalogue "Instruments pour la chirurgie maxillo-faciale" demeure notre propriété, même après acquittement d'une taxe autorisée ou taxe de prêt. Il ne peut être utilisé que pour l'achat ou la vente des produits MEDICON qui y sont décrits, par des spécialistes et étant autorisés et par l'utilisateur pour l'approvisionnement de ses besoins. Son utilisation contre nos intérêts nous autorise à une demande en restitution immédiate et à la prise éventuelle de mesures disciplinaires. Sans autorisation formelle écrite, ce catalogue ne peut être ni réimprimé, ni copié, que ce soit complètement ou partiellement.

Il presente catalogo "Strumenti per la chirurgia maxillo-facciale" rimane di nostra proprietà anche se è stato pagato un diritto di noleggio o di proprietà riservata. Esso può essere adoperato soltanto per l'acquisto e la vendita dei prodotti MEDICON ivi descritti attraverso il commercio specializzato e autorizzato o per l'approvvigionamento tramite chi, di volta in volta, li impiega. L'uso del catalogo contro i nostri interessi ci autorizza al suo immediato ritiro e possibili ulteriori provvedimenti. Senza la nostra esplicita autorizzazione scritta questo catalogo non può essere ristampato o copiato né integralmente né parzialmente.

Modelländerungen vorbehalten
Patterns are subject to change
Salvo modificaciones
Tous droits réservés des changements de modèle
Ci riserviamo la facoltà di cambiamenti nei modelli

Für Druckfehler übernehmen wir keinerlei Haftung
We are not liable for misprints
Declinamos toda responsabilidad por los errores de impresión que pueda contener este documento
Nous déclinons toute responsabilité en cas d'erreurs d'impression
Non ci assumiamo nessuna responsabilità per eventuali errori di stampa

Gedruckt in Deutschland
Printed in Germany
Impreso en Alemania
Imprimé en Allemagne
Stampato in Germania
Trykkt i Tyskland

© Copyright 06/2015, MEDICON eG, Tuttlingen, Germany

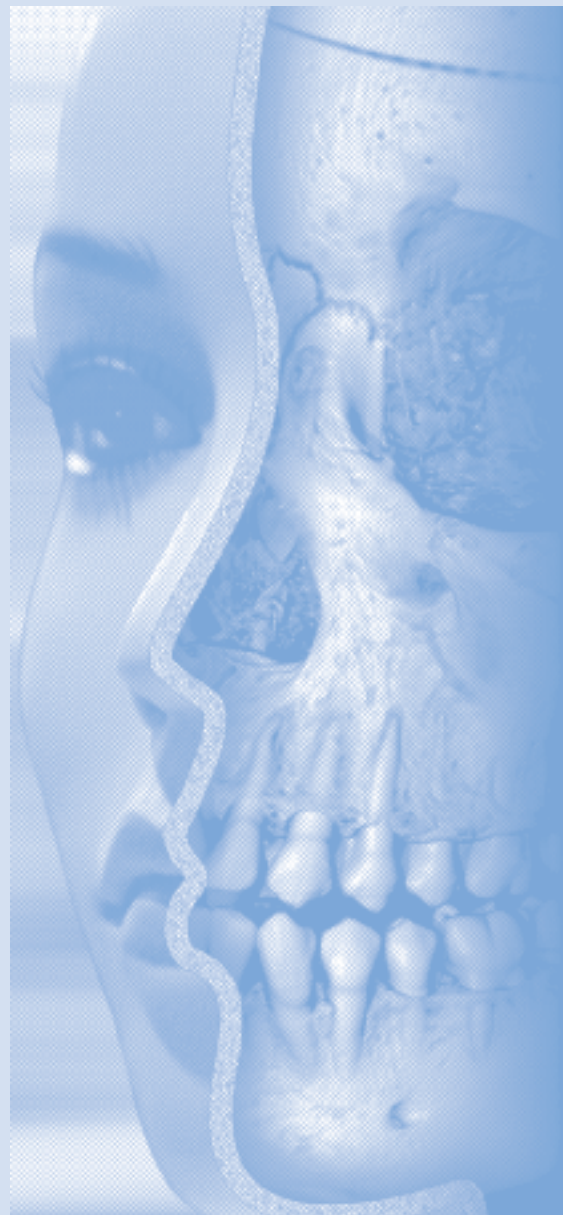



BASIC INSTRUMENTS

1

OMF INSTRUMENTS

57

SPECIALITIES

147

SET SUGGESTIONS

177

INDEX

215

A

Standardinstrumente Basic Instruments Instrumentos básicos Instruments de base Strumenti di base

A01	Skalpellsklingen und Skalpellgriffe Scalpel blades and scalpel handles Hojas de bisturí y mangos de bisturí Lames de bistouris et manches pour bistouris Lame per bisturi e manici per bisturi	2
A02	Scheren Scissors Tijeras Ciseaux Forbici	5
A03	Pinzetten Forceps Pinzas Pincas Pinze	19
A04	Bipolare Antihaf-Pinzetten Bipolar non-sticking forceps Pinzas bipolares no adherentes Pincas bipolaires anti-adhésives Pinze bipolarari antiaderenti	27
A05	Nadelhalter Needle holders Porta-agujas Porte-aiguilles Portaghi	33
A06	Saug- und Spülinstrumente Suction and irrigating instruments Instrumentos de aspiración y de lavado Instruments à aspiration et à irrigation Strumenti per aspirazione e lavaggio	39
A07	Sonden Probes Estiletes Stylets Specilli	45
A08	Klemmen Clamps Pinzas Clamps Pinze	49
A09	Kornzangen Dressing forceps Pinzas para curaciones Pincas à pansements Pinze per medicazione	54

B

Instrumente für die Mund-, Kiefer- und Gesichtschirurgie Instruments for Oral and Maxillofacial Surgery Instrumentos para cirugía oral y maxilofacial Instruments pour la chirurgie maxillo-faciale Strumenti per la chirurgia maxillo-facciale

B01	Wundhaken Retractors Separadores Ecarteurs Divaricatori	58
B02	Lidhalter und Orbitahaken Lid retractors and orbital hooks Separadores para párpados y separadores orbitales Releveurs à paupières et crochets orbitaux Elevatori per palpebre e retrattore orbitale	83
B03	Wundspreizer, Nasenhaken und Lidplatte Self-retaining retractors, nasal retractors and lid plate Separadores autoestáticos, separadores nasales y placa para párpados Ecarteurs autostatiques, ecarteurs nasaux et plaque à paupières Divaricatori autostatici, divaricatori nasali e piastra per palpebre	84
B04	Lippen- und Wangenhalter Lip and cheek retractors Separadores de labios y mejillas Ecarteurs de lèvres et de joues Divaricatori per labbra e guance	86
B05	Zungenspatel, Zungendrücken und Mundsperrer Tongue spatulas, tongue depressor and mouth gags Espátulas bucales, bajalengua y abrebocas Spatules à langue, abaisse-langue et ouvre-bouches Spatole per lingua, abbassalingua e apribocca	88
B06	Raspatorien und Elevatorien Raspatories and elevators Legras y elevadores Rugines et élévateurs Periostotomi ed elevatori	97
B07	Knocheninstrumente Bone instruments Instrumentos para huesos Instruments à os Strumenti per ossa	105
B08	Messinstrumente Measuring instruments Instrumentos para medir Instruments à mesurer Strumenti per misurare	129
B09	Drähte, Drahtinstrumente und Ahlen Wires, wire instruments and awls Alambres, instrumentos para alambres y leznas Fils, instruments pour fils métalliques et alènes Fili, strumenti per fili d'acciaio e punteruoli	133
B10	Lippen- und Gaumenspalteninstrumente Lip and cleft palate instruments Instrumentos para labios y fisuras paladares Instruments pour lèvres et fissures palatines Strumenti per labbra e fessure del palato	138
B11	Sinuslifting-Instrumente Sinuslifting instruments Instrumentos para sinus-lift Instruments pour sinus-lift Strumenti per sinus-lifting	141

C

Spezialitäten Specialities Especialidad Spécialités Specialiti

C01	Spekulum und Nasenraspeln Speculum and nasal rasps Espéculo y raspadores nasales Spéculum et râpes nasales Specolo e raspe nasali	“Kluba”	148
C02	Nasenraspeln Nasal rasps Raspadores nasales Râpes nasales Raspe nasali	“X-Change”	149
C03	Instrumente für den Beckenkamm Instruments for the pelvic crest Instrumentos para la cresta iliaca Instruments pour la crête iliaque Strumenti per la cresta iliaca	“Cristaca”	150
C04	Zylinder-Osteotome Cylinder osteotomes Osteótomos cilíndricos Ostéotomes cylindriques Osteotomi cilindrici	“Shepard”	153
C05	Knochenmühlen Bone mills Molinos de hueso Moulins à os Mulini per ossa		154
C06	Fibula-Raspatorium Fibula raspatory Legra para fibula Fibula rugine Fibula periostotomo	“Hakim”	155
C07	Instrumente für Frakturen des Collum mandibulae Instruments for mandibular collum fractures Instrumentos para las fracturas en el cuello mandibular Instruments pour les fractures du col mandibulaire Strumenti per fratture del collum mandibulae	“Hakim”	156
C08	Chirurgische Handstücke Surgical hand pieces Piezas de mano quirúrgicas Pièces à main chirurgicales Manipoli chirurgici		160
C09	Winkelschraubendreher Angular screwdrivers Destornilladores de ángulo Tournevis angulaire Cacciaviti angolati		162
C10	Mikro-Sägen Micro saws Micro sierras Micro scies Micro seghe		165

D

Siebvorschläge Set Suggestions Proposiciones de juegos Propositions pour boîtes Proposte di sets

D01	Rhinoplastik Rhinoplasty Rinoplastia Rhinoplastie Rinoplastica	“Gubisch” “Daniel”	178
D02	Lidkorrektur Eyelid correction Corrección de párpados Correction des paupières Chirurgia delle palpebre		185
D03	Lipofilling Lipofilling Lipofilling Lipostructure Lipofilling		186
D04	Sinuslifting Sinus Lifting Alzamiento sinusal Lifting des sinus Sinus lifting		187
D05	Mikrochirurgischer Gaumenverschluss Microsurgical palate closure Cierre del paladar con microcirugía Fermeture microchirurgicale du palais Chiusura microchirurgica del palato		188
D06	Lippen-, Kiefer- und Gaumenspalten Lip, jaw and palate fissures Fisuras palatinas, labiales y maxilares Fentes labiales, maxillaires et palatines Labio-palatoschisi		190
D07	Dysgnathie Dysgnathia Disgnatia Dysgnathie Disgnatia		193
D08	Spongiosaentnahme aus dem Beckenkamm Removal of spongiosa from the iliac crest Extracción de sustancia esponjosa de la cresta iliaca Prélèvement d'os spongieux sur la crête iliaque Prelievo di spongiosa dalla cresta iliaca	“Christaca” “Shepard”	198
D09	Frakturbehandlung Fracture treatment Tratamiento de fracturas Traitement des fractures Trattamento di frattura		202
D10	Orbitarekonstruktion Orbital reconstruction Reconstrucción de la cavidad orbitaria Reconstruction orbitale Ricostruzione dell'orbita		206
D11	Weichteilbehandlung Soft tissue therapy Tratamiento de tejido blando Traitement des parties molles Trattamento dei tessuti molli		209

E

Alphabetischer und numerischer Index
Alphabetical and Numerical Index
Índice alfabético y numérico
Index alphabétique et numérique
Índice alfabético e numerico

E01	Alphabetischer Index	DEUTSCH	216
E02	Alphabetical index	ENGLISH	222
E03	Índice alfabético	ESPAÑOL	228
E04	Index alphabétique	FRANÇAIS	233
E05	Índice alfabético	ITALIANO	238
E06	Numerischer Index Numerical index Índice numérico Index numérique Índice numerico		246

Hinweise
Indications
Indicaciones
Indications
Indicazioni

Unsere Instrumenten-Abbildungen haben eine Größe von 50 %. Andere Darstellungsgrößen werden im Maßstab (zum Beispiel 1:1) angegeben. Die dazugehörigen Detailbilder sind in Originalgröße (100 %) abgebildet. Die angegebenen Bemaßungen unterliegen herstellungsbedingt einer Fertigungstoleranz.

In general the instrument illustrations are scaled to be 50 % of actual size. If other scales are used they are indicated (for example 1:1). The corresponding detailed tip illustrations are shown in actual size (100 %). The stated measurements may have a slight variation in permissible tolerances due to minor variations in manufacturing conditions.

Las ilustraciones de los instrumentos tienen un tamaño de 50 %. Otros tamaños de las ilustraciones serán indicados con la indicación en una escala (por ejemplo 1:1). Los imagenes detallados pertinentes son en su tamaño original (100 %). Las dimensiones indicadas son sujeto de tolerancias.

Nos illustrations d'instruments sont à 50 % de la taille réelle. D'autres dimensions de représentation sont données avec indication d'échelle (par exemple 1:1). Les images de détail sont projetées en taille réelle (100 %). Toutes les dimensions données ont une tolérance de fabrication.

Le illustrazioni dei nostri strumenti hanno una dimensione del 50 %. Altre dimensioni di raffigurazione sono segnate con una scala (per esempio 1:1). Le relative illustrazioni dettagliate sono illustrate in dimensioni originali (100 %). Le dimensioni indicate sono soggette a una tolleranza di fabbricazione.

Beispiel
 Example
 Ejemplo
 Exemple
 Esempio

Vorderansicht (Schere gerade)
 Front view (straight scissors)
 Vista frontal (tijera recta)
 Vue de face (ciseaux droits)
 Vista frontale (forbice retta)

Seitenansicht (Schere gebogen)
 Lateral view (curved scissors)
 Vista lateral (tijera curva)
 Vue laterale (ciseaux courbes)
 Vista laterale (forbice curva)

50 % = 7 cm



Mayo

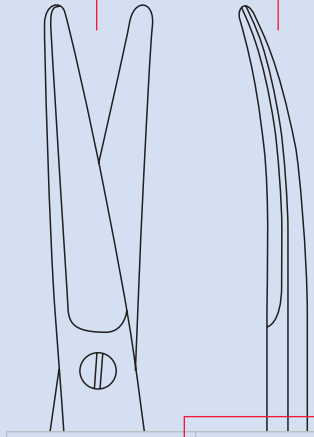

Darstellungsgröße
 Image size
 Tamaño de representación
 Dimension de représentation
 Dimensione di raffigurazione

1:1

Instrumentengröße
 Instrument size
 Tamaño del instrumento
 Taille des instruments
 Dimensione degli strumenti

14 cm – 5½"	14 cm – 5½"	
03.50.14	03.51.14	standard
203.50.14	203.51.14	supercut
213.50.14	213.51.14	blackline
03.50.64	03.51.64	"HM"
203.50.64	202.51.64	supercut plus
223.50.64	222.51.64	magiccut

Artikelnummer
 Item number
 Número de artículo
 Référence
 Codice

MEDICON

instruments

OMF - SURGERY

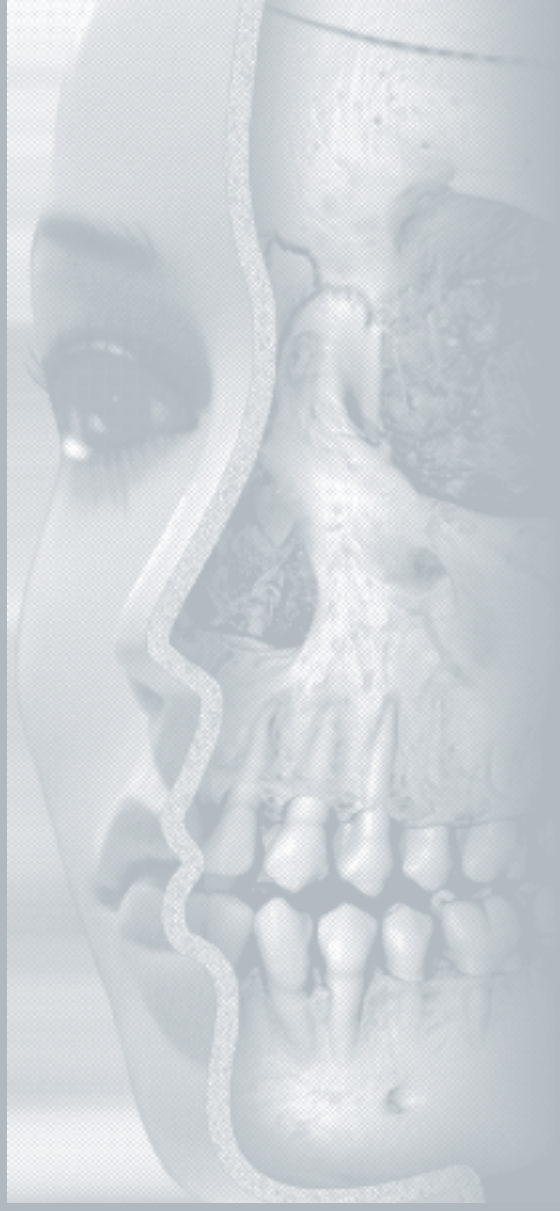

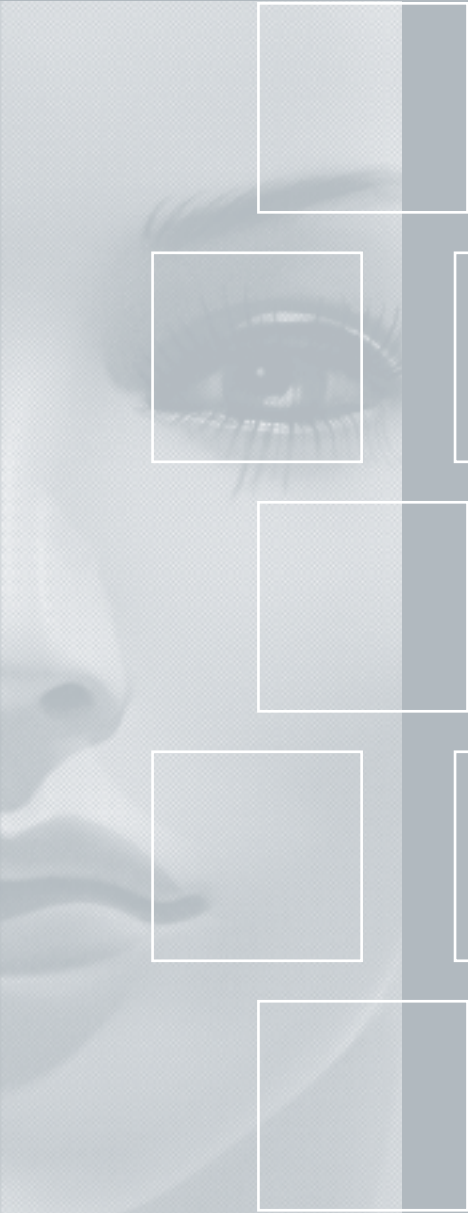

BASIC INSTRUMENTS



A01

Skalpellklingen und Skalpellgriffe
Scalpel Blades and Scalpel Handles
Hojas de bisturí y mangos de bisturí
Lames de bistouris et manches pour bistouris
Lame per bisturi e manici per bisturi



1:1

 **STERILE**





Fig. 10 **01.22.10** 





Fig. 11 **01.22.11** 





Fig. 12 **01.22.12** 



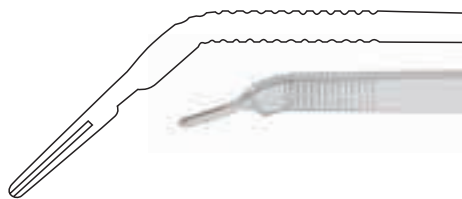



Fig. 15 **01.22.15** 



Verpackung für Skalpellklingen
 Packing for scalpel blades
 Paquete para hojas de bisturí
 Emballage pour lames de bistouris
 Confezione per lame per bisturi

12,5 cm – 5" **01.27.03** no. 3



12,0 cm – 4¾" **01.27.17** no. 7K



16,5 cm – 6½" **01.27.07** no. 7



15,5 cm – 6⅛" **01.27.40**



15,5 cm – 6⅛" **01.30.38** **Blake**



21,0 cm – 8¼" **01.27.13** no. 3L



20,5 cm – 8" **01.27.23** no. 3LA



Einmalprodukt
 Single use product
 Producto para un solo uso
 Produit à usage unique
 Prodotto monouso



Verpackungseinheit "X" Stück
 Packing unit "X" pieces
 Paquete de "X" unidades
 Emballage de "X" pièces
 Confezione da "X" pezzi

Skalpellklingen und Skalpellgriffe
Scalpel Blades and Scalpel Handles
Hojas de bisturí y mangos de bisturí
Lames de bistouris et manches pour bistouris
Lame per bisturi e manici per bisturi

A01

1:1

⊗ **STERILE**



Fig. 18 **01.22.18** P₁₀₀

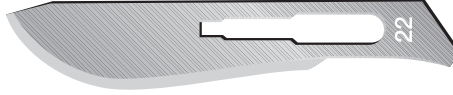

Fig. 22 **01.22.22** P₁₀₀



Fig. 19 **01.22.19** P₁₀₀



Fig. 23 **01.22.23** P₁₀₀



Fig. 20 **01.22.20** P₁₀₀



Fig. 24 **01.22.24** P₁₀₀



Fig. 21 **01.22.21** P₁₀₀



Fig. 25 **01.22.25** P₁₀₀



Verpackung für Skalpellklingen
 Packing for scalpel blades
 Paquete para hojas de bisturí
 Emballage pour lames de bistouris
 Confezione per lame per bisturi



13,5 cm – 5³/₈" **01.28.04** no. 4



21 cm – 8¹/₄" **01.28.14** no. 4L

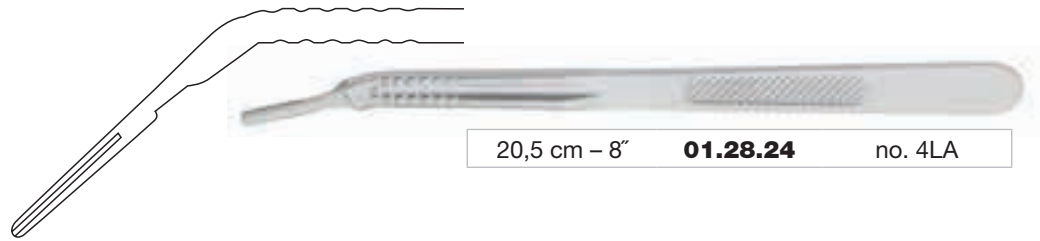

20,5 cm – 8" **01.28.24** no. 4LA



Einmalprodukt
 Single use product
 Prodotto para un solo uso
 Produit à usage unique
 Prodotto monouso



Verpackungseinheit "X" Stück
 Packing unit "X" pieces
 Paquete de "X" unidades
 Emballage de "X" pièces
 Confezione da "X" pezzi



A01

Skalpellklingen und Skalpellgriffe
Scalpel Blades and Scalpel Handles
Hojas de bisturí y mangos de bisturí
Lames de bistouris et manches pour bistouris
Lame per bisturi e manici per bisturi

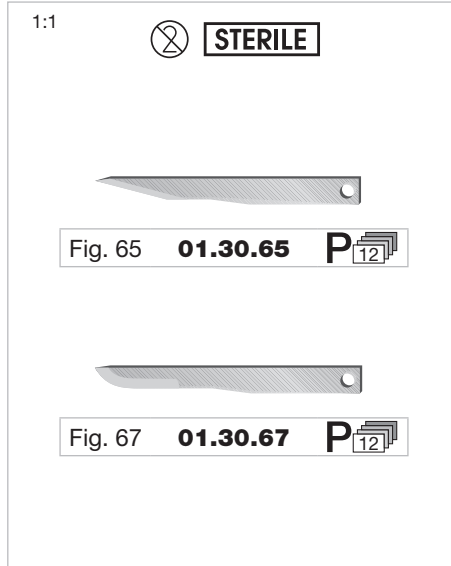

13,0 cm – 5 1/8" **01.30.32**



15,5 cm – 6 1/8" **01.30.36**



Einmalprodukt
 Single use product
 Producto para un solo uso
 Produit à usage unique
 Prodotto monouso

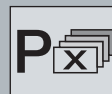

Verpackungseinheit "X" Stück
 Packing unit "X" pieces
 Paquete de "X" unidades
 Emballage de "X" pièces
 Confezione da "X" pezzi

Von "standard" bis "magic cut" – alle Scheren werden von fachkundigen Chirurgiemechanikern hergestellt. Sie werden für dauerhafte Leistung sorgfältig gehärtet und qualitätsgerecht geprüft.

Starting with "standard" up to "magic cut" – all scissors are manufactured by experienced professionals. They are thoroughly hardened to ensure a long-lasting performance and are quality-checked.

Desde tijeras "standard" hasta "magic cut" – todas las tijeras son fabricadas por expertos competentes. Las tijeras son templadas e investigadas respecto la calidad para un durable rendimiento.

De "standard" à "magic cut" – tous les ciseaux sont fabriqués par des mécaniciens de chirurgie compétents. Ils sont trempés soigneusement afin d'obtenir une performance durable et passent un contrôle de qualité.

Dalla "standard" alla "magic cut" – tutte le forbici sono prodotte da meccanici chirurgici specializzati. Per una lunga durata sono temprate accuratamente e devono passare il controllo di qualità.



451.03.23

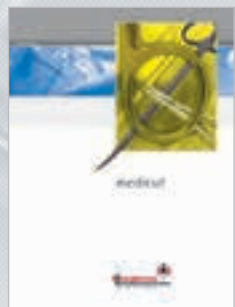

Unser komplettes Scheren-Programm finden Sie in unserem Sonderprospekt.
For our complete line of scissors, see our special brochure.
El programa completo de tijeras se encuentra en nuestro folleto especial.
Vous trouverez notre gamme complète de ciseaux dans notre brochure spéciale.
Troverete il nostro programma completo di forbici nel nostro depliant speciale.



A02

Farbcodierung
Color Coding
Codificación de color
Codage couleur
Codice colore

supercut

Goldene Schraube
Golden screw
Tornillo dorado
Vis dorée
Vite dorata



black line

Goldene Schraube und schwarze Ringgriffe
Golden screw and black rings
Tornillo dorado y anillos negros
Vis dorée et anneaux noirs
Vite dorata e anelli neri



"HM"

Goldene Ringgriffe
Golden rings
Anillos dorados
Anneaux dorés
Anelli dorati



supercut plus

Goldene Schraube und goldene Ringgriffe
Golden screw and golden rings
Tornillo dorado y anillos dorados
Vis dorée et anneaux dorés
Vite dorata e anelli dorati



magic cut

Keramikbeschichtung und goldene Schraube
Ceramic coating and golden screw
Recubrimiento de cerámica y tornillo dorado
Couche céramique et vis dorée
Rivestimento di ceramica e vite dorata



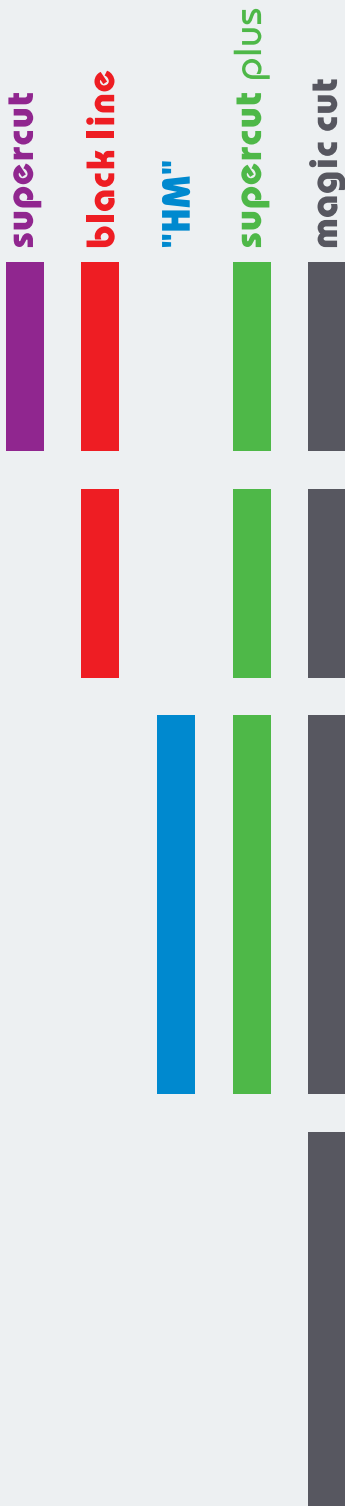

Messerschliiff und Mikroverzahnung: Feiner, minimal traumatisierender Schnitt
Knife edge and micro serration: Fine, minimally traumatizing cut
Hoja de bisturí y dentadura micro: Corte fino, mínimo traumatizante
Aiguisement tranchant et dents micro: Coupe fine, peu traumatisante
Affilatura a scalpello e dentellatura micro: Taglio fine, minimamente traumatizzante

Zusätzlicher Anschlag einer Blattrückseite: Bessere Sicht · Präzise Präparation
Reduction of the transversal cut: Better visibility · Precise dissection
Reducción del corte transversal: Visión mejorada · Disección precisa
Coupe transversale réduite: Vue améliorée · Dissection précise
Riduzione del taglio trasversale: Vista migliorata · Dissezione precisa

Eingeschweißte Hartmetallschneiden: Nahtlose, homogene und korrosionsfreie Verbindung von Hartmetall und Scherenstahl
Welded tungsten carbide cutting edges: Seamless, homogenous and corrosion-free junction of tungsten carbide and scissors steel
Hojas soldadas de carburo de tungsteno: Unión sin costuras, homogénea y resistente a la corrosión del carburo de tungsteno con el acero
Lames soudées d'un alliage de carbure de tungstène: Jointure sans trace, homogène et résistante à la corrosion du carbure de tungstène avec l'acier des ciseaux
Lame saldate al carburo di tungsteno: Congiunzione senza saldature, omogenea e resistente alla corrosione del carburo di tungsteno e all'acciaio delle forbici

Keramikbeschichtung: Lange Standzeit · Hohe Oberflächenhärte · Blendfreie Oberfläche · Hervorragende Gleitfähigkeit
Ceramic coating: Long lasting cutting ability · High surface hardness · Non-dazzling surface · Excellent sliding capacity
Recubrimiento de cerámica: Máxima duración del corte · Alta dureza de la superficie · Superficie antideslumbrante · Deslizamiento destacado
Couche céramique: Longue durée de vie · Grande dureté de la surface · Surface non-éblouissante · Glissement excellent
Rivestimento di ceramica: Massima durata del taglio · Alta durezza della superficie · Superficie antiriflesso · Eccellente scorrimento



A02

Feine Scheren
Delicate Scissors
Tijeras finas
Ciseaux délicats
Forbici delicate



Wagner

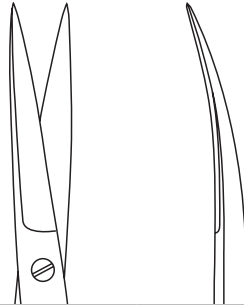

12 cm – 4¾"	12 cm – 4¾"	
02.06.12	02.07.12	standard

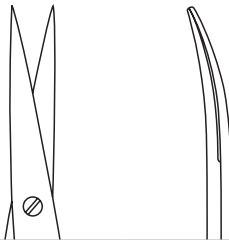

12 cm – 4¾"	12 cm – 4¾"	
02.26.12	02.27.12	standard





14,5 cm – 5¾"	14,5 cm – 5¾"	
03.02.14	03.03.14	standard
203.02.14	203.03.14	supercut
213.02.14	213.03.14	black line
03.02.64	03.03.64	"HM"



14,5 cm – 5¾"	14,5 cm – 5¾"	
03.04.14	03.05.14	standard
203.04.14	203.05.14	supercut
213.04.14	213.05.14	black line
03.04.64	03.05.64	"HM"



A02

Chirurgische Scheren und Tonsillenscheren
Operating Scissors and Tonsil Scissors
Tijeras quirúrgicas y tijeras para amígdalas
Ciseaux chirurgicaux et ciseaux à amygdales
Forbici chirurgiche e forbici per tonsille

Chirurgische Scheren
 Operating scissors
 Tijeras quirúrgicas
 Ciseaux chirurgicaux
 Forbici chirurgiche



14,5 cm – 5¾"	14,5 cm – 5¾"	
03.06.14	03.07.14	standard
203.06.14	203.07.14	supercut
213.06.14	213.07.14	black line
03.06.64	03.07.64	"HM"

Tonsillenscheren
 Tonsil scissors
 Tijeras para amígdalas
 Ciseaux à amygdales
 Forbici per tonsille

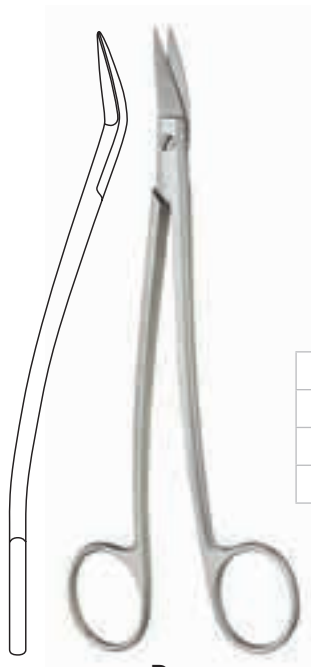

Dean

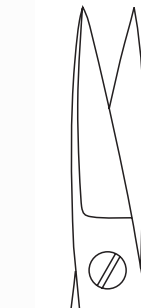

17 cm – 6¾"	
72.45.50	standard
272.45.50	supercut
282.45.50	black line



Eine Schneide gezahnt
 One blade serrated
 Una hoja dentada
 Une lame dentelée
 Una lama dentellata

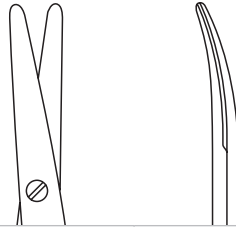

12 cm – 4¾"	12 cm – 4¾"	
02.40.12	02.41.12	standard
202.40.12	202.41.12	supercut
212.40.12	212.41.12	black line
02.40.62	02.41.62	"HM"
202.40.62	202.41.62	supercut plus
222.40.62	222.41.62	magic cut

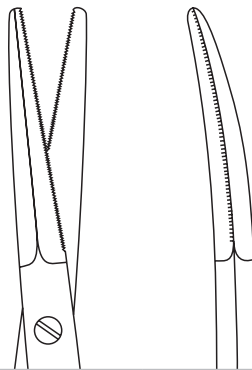

14 cm – 5½"	14 cm – 5½"	
02.70.14	02.71.14	standard

Beuse



Beide Schneiden gezahnt
 Both blades serrated
 Ambas hojas dentadas
 Les deux lames dentelées
 Entrambe le lame dentellate



A02

Feine Präparierscheren
Delicate Dissecting Scissors
Tijeras finas para disección
Ciseaux délicats pour dissection
Forbici delicate per dissezione



Ragnell (Kilner)

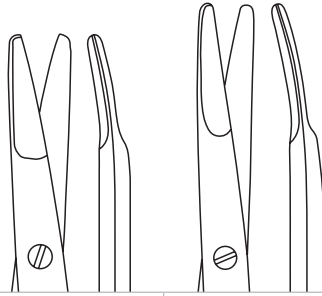

13 cm – 5 1/8"	15 cm – 6"	
04.13.13	04.13.15	standard
204.13.13	204.13.15	supercut
214.13.13	214.13.15	black line
04.13.63	04.13.65	"HM"
204.13.63	204.13.65	supercut plus



Baby-Metzenbaum

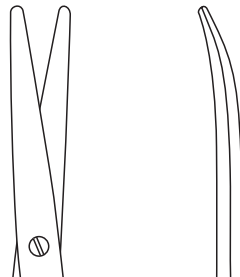

11,5 cm – 4 1/2"	11,5 cm – 4 1/2"	
04.32.11	04.33.11	standard
204.32.11	204.33.11	supercut
214.32.11	214.33.11	black line
04.32.61	04.33.61	"HM"
204.32.61	204.33.61	supercut plus
224.32.61	224.33.61	magic cut



Joseph

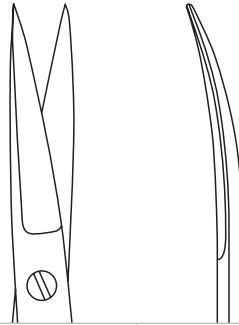

15 cm – 6"	15 cm – 6"	
04.50.15	04.51.15	standard
204.50.15	204.51.15	supercut
214.50.15	214.51.15	black line



Kelly

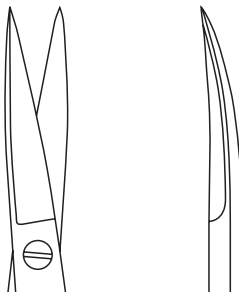

16 cm – 6¼"	16 cm – 6¼"	
04.54.16	04.55.16	standard
204.54.16	204.55.16	supercut
214.54.16	214.55.16	black line
04.54.66	04.55.66	"HM"
204.54.66	204.55.66	supercut plus
224.54.66	224.55.66	magic cut



A02

Präparierscheren
Dissecting Scissors
Tijeras para disección
Ciseaux pour dissection
Forbici per dissezione



Mayo

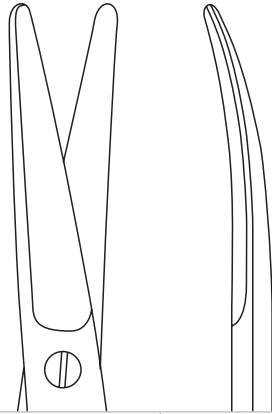

14,5 cm – 5¾"	14,5 cm – 5¾"	
03.50.14	03.51.14	standard
203.50.14	203.51.14	supercut
213.50.14	213.51.14	black line
03.50.64	03.51.64	"HM"
203.50.64	203.51.64	supercut plus
223.50.64	223.51.64	magic cut



Mayo-Stillie



15 cm – 6"	15 cm – 6"	
03.56.15	03.57.15	standard
203.56.15	203.57.15	supercut
213.56.15	213.57.15	black line
03.56.65	03.57.65	"HM"
203.56.65	203.57.65	supercut plus
223.56.65	223.57.65	magic cut



Metzenbaum-slim

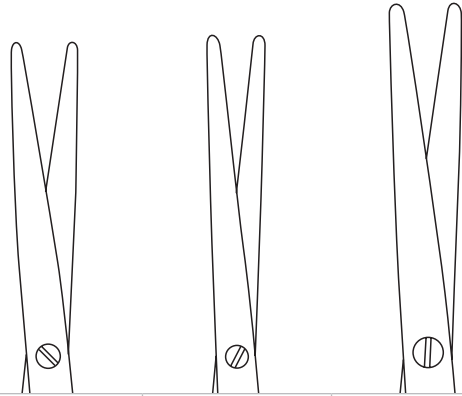

14 cm – 5½"	18 cm – 7¼"	20 cm – 8"	
04.34.14	04.34.18	04.34.20	standard
204.34.14	204.34.18	204.34.20	supercut
214.34.14	214.34.18	214.34.20	black line
04.34.64	04.34.68	04.34.70	"HM"
204.34.64	204.34.68	204.34.70	supercut plus



Metzenbaum-slim

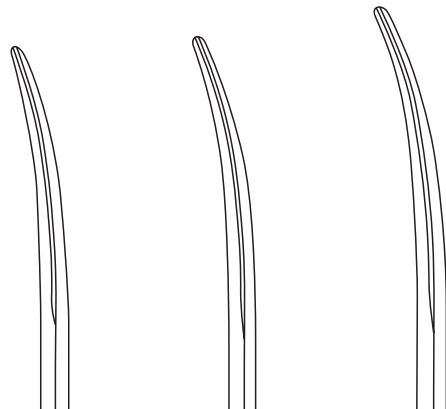

14 cm – 5½"	18 cm – 7¼"	20 cm – 8"	
04.35.14	04.35.18	04.35.20	standard
204.35.14	204.35.18	204.35.20	supercut
214.35.14	214.35.18	214.35.20	black line
04.35.64	04.35.68	04.35.70	"HM"
204.35.64	204.35.68	204.35.70	supercut plus
224.35.64	224.35.68	224.35.70	magic cut



A02

Präparierscheren und Zahnfleischscheren
Dissecting Scissors and Gum Scissors
Tijeras para disección y tijeras para encías
Ciseaux pour dissection et ciseaux à gencive
Forbici per dissezione e forbici per gengiva



Präparierscheren
 Dissecting scissors
 Tijeras para disección
 Ciseaux pour dissection
 Forbici per dissezione



Toennis-Adson

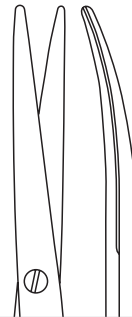

18 cm – 7 1/8"	
04.63.18	standard
204.63.18	supercut
214.63.18	black line
04.63.68	"HM"
204.63.68	supercut plus
224.63.68	magic cut

Zahnfleischscheren
 Gum scissors
 Tijeras para encías
 Ciseaux à gencive
 Forbici per gengiva



Fox

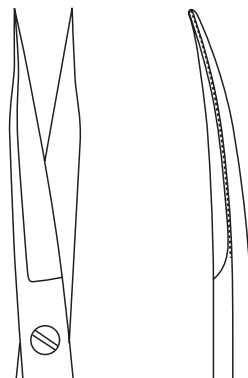

13 cm – 5 1/8"	13 cm – 5 1/8"	
04.80.13	04.81.13	standard
204.80.13	204.81.13	supercut
214.80.13	214.81.13	black line
04.80.63	04.81.63	"HM"
204.80.63	204.81.63	supercut plus



Eine Schneide gezahnt
 One blade serrated
 Una hoja dentada
 Une lame dentelée
 Una lama dentellata

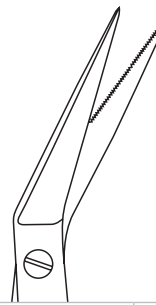
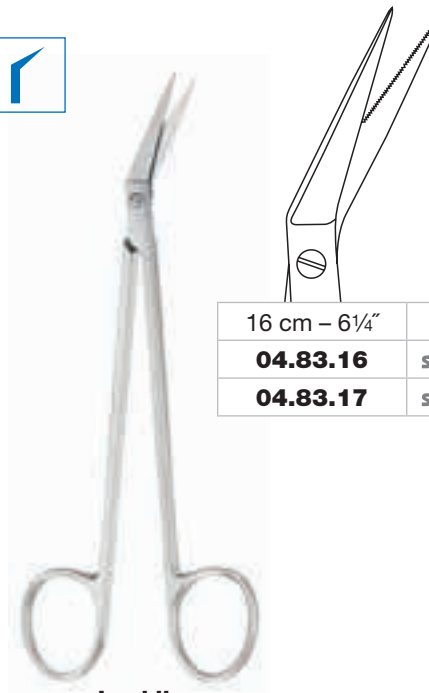

16 cm – 6¼"	
04.83.16	standard
04.83.17	standard



Locklin

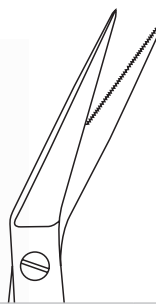

16 cm – 6¼"	
04.83.26	standard
04.83.27	standard



Locklin



Eine Schneide gezahnt
 One blade serrated
 Una hoja dentada
 Une lame dentelée
 Una lama dentellata



seitwärts gewinkelt
 angled to side
 acodadas lateralmente
 coudés latéralement
 angolata lateralmente

the art of surgery

Weitere MEDICON-Produkte finden Sie in unserem Hauptkatalog.

You will find further MEDICON products in our main catalogue.



Más productos de MEDICON se encuentra en nuestro catálogo general.

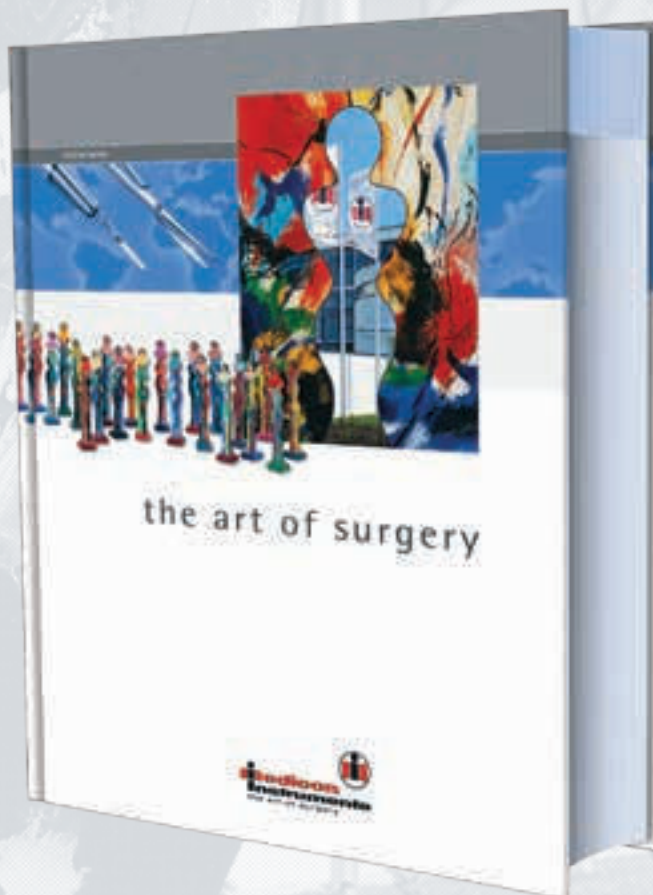

Vous trouverez d'autres produits MEDICON dans notre catalogue général.

Altri prodotti MEDICON si trovano nel nostro catalogo generale.











		
11,5 cm – 4½"	13 cm – 5⅛"	14,5 cm – 5¾"
06.00.11	06.00.13	06.00.14

		
15 cm – 6"	16 cm – 6¼"	18 cm – 7⅛"
06.00.15	06.00.16	06.00.18



		
11,5 cm – 4½"	13 cm – 5⅛"	14,5 cm – 5¾"
06.02.11	06.02.13	06.02.14

		
15 cm – 6"	16 cm – 6¼"	18 cm – 7⅛"
06.02.15	06.02.16	06.02.18



A03

Anatomische und chirurgische Pinzetten
Dressing and Tissue Forceps
Pinzas anatómicas y quirúrgicas
Pinces anatomiques et chirurgicales
Pinze anatomiche e chirurgiche



Potts-Smith "HM"

14,5 cm – 5¾"	18 cm – 7⅛"	23 cm – 9"
06.03.65	06.03.68	06.03.73



Cushing



17 cm – 6¾"	17 cm – 6¾"
06.60.17	06.60.87



Cushing



18 cm – 7⅛"	18 cm – 7⅛"
06.60.18	06.60.88

"HM"
 Hartmetall
 Tungsten carbide
 Carburo de tungsteno
 Carbure de tungstène
 Carburo di tungsteno

mit Dissektorende
 with dissector end
 con extremo sirviendo de legra
 avec extrémité dissecteur
 con la parte finale a forma di dissettore

Anatomische und chirurgische Pinzetten
 Dressing and Tissue Forceps
 Pinzas anatómicas y quirúrgicas
 Pincas anatomiques et chirurgicales
 Pinze anatomiche e chirurgiche

A03



Gerald

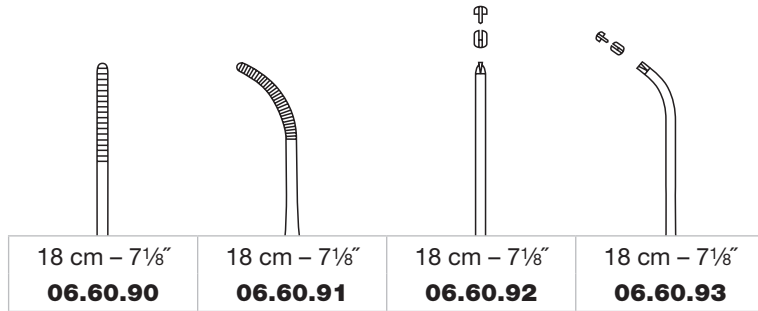

McIndoe

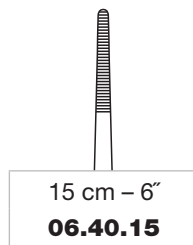

Cushing "HM"

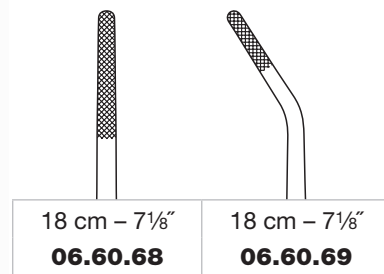

"HM"

Hartmetall
 Tungsten carbide
 Carburo de tungsteno
 Carbure de tungstène
 Carburo di tungsteno

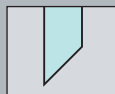

mit Dissektorende
 with dissector end
 con extremo sirviendo de legra
 avec extrémité dissecteur
 con la parte finale a forma di dissettore



A03

Feine Pinzetten, anatomisch und chirurgisch
Delicate Forceps, dressing and tissue
Pinzas finas, anatómicas y quirúrgicas
Pinces délicates, anatomiques et chirurgicales
Pinze delicate, anatomiche e chirurgiche

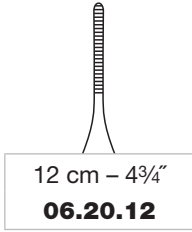

Adson

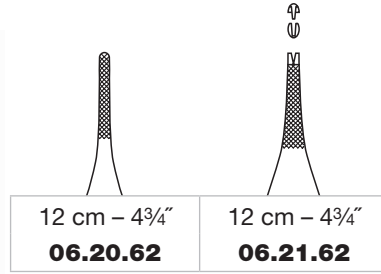

Adson "HM"

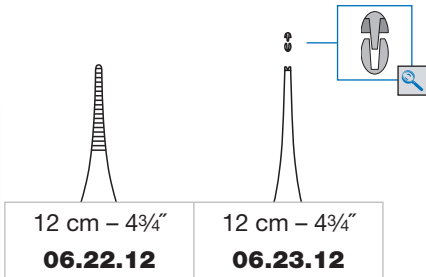

Micro-Adson

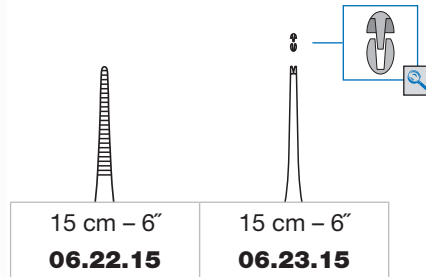

Micro-Adson

"HM"
 Hartmetall
 Tungsten carbide
 Carburo de tungsteno
 Carbure de tungstène
 Carburo di tungsteno

Vergrößerung
 Magnification
 Engrandecimiento
 Agrandissement
 Ingrandimento

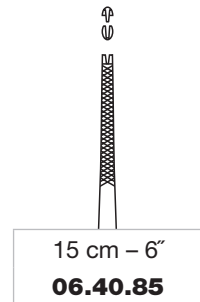
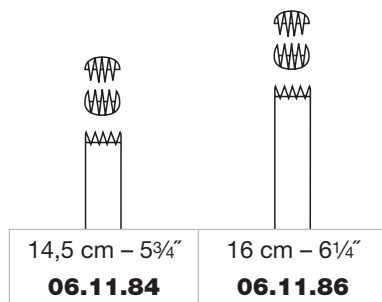
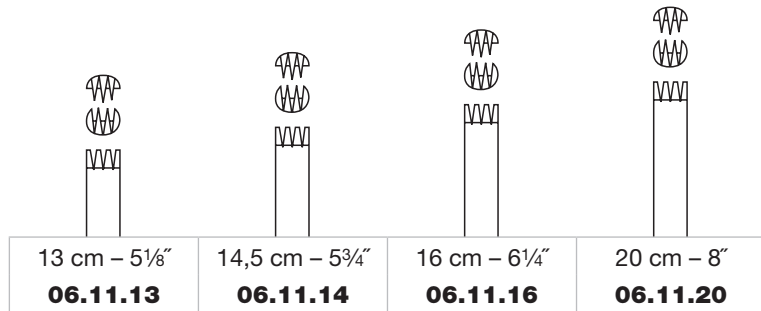
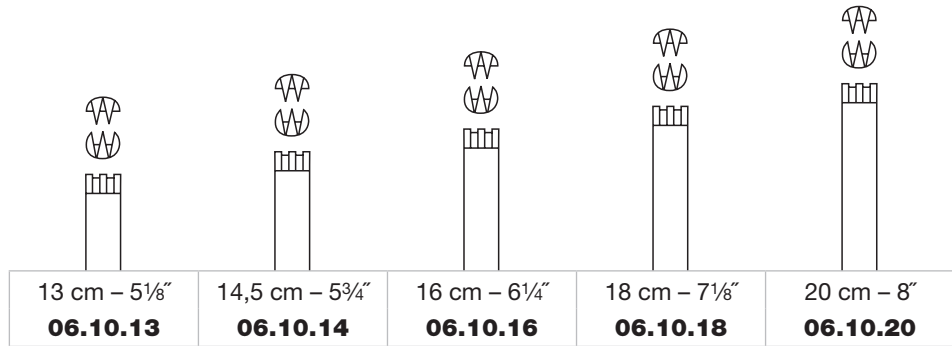

Gillies



A03

Gewebefasspinzetten und Lidfasspinzette
Tissue Grasping Forceps and Lid Grasping Forceps
Pinzas para agarrar tejidos y pinza para agarrar párpados
Pinces pour saisir le tissu et pince à saisir les paupières
Pinze per afferrare tessuti e pinza per afferrare palpebre



Gewebefasspinzetten
 Tissue grasping forceps
 Pinzas para agarrar tejidos
 Pinces pour saisir le tissu
 Pinze per afferrare tessuti



Brown

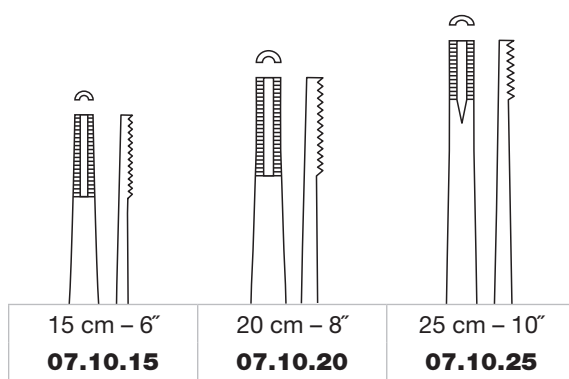

Lidfasspinzette
 Lid grasping forceps
 Pinza para agarrar párpados
 Pince à saisir les paupières
 Pinza per afferrare la palpebra



Walter

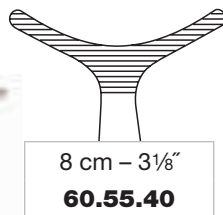

Mikro-Pinzetten
 Micro forceps
 Micro pinzas
 Micro pinces
 Micro pinze



micro 2000

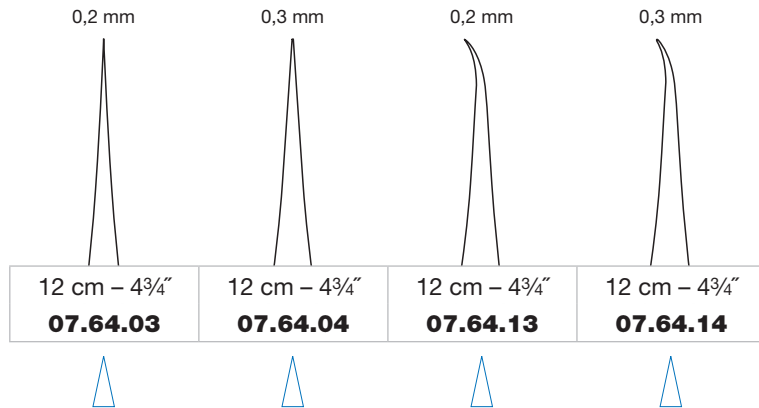

Juwelierpinzetten
 Jeweler's forceps
 Pinzas para joyero/relojero
 Pinces pour joaillier/horloger
 Pinze per gioielliere/orologiaio

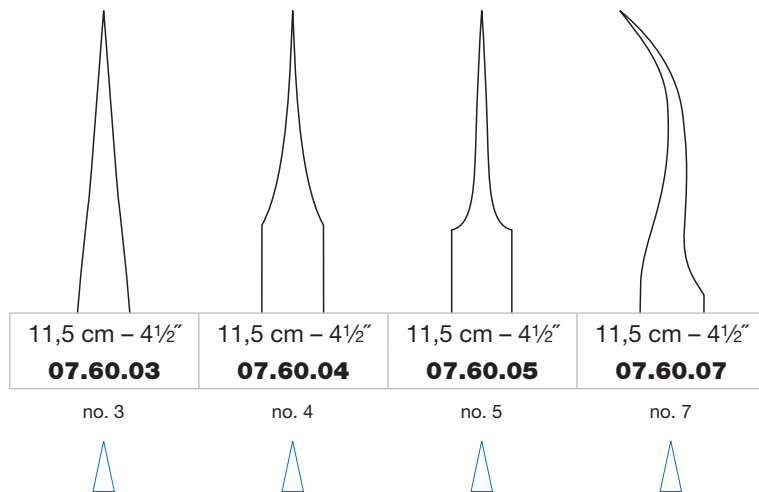



A03

Bajonettpinzetten
Bayonet Forceps
Pinzas en forma bayoneta
Pinces en forme baïonnette
Pinze a forma baionetta



a

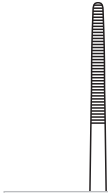

a = 80 mm
 18,5 cm - 7 1/4"
07.26.18



a = 95 mm
 19,5 cm - 7 3/4"
07.26.19



a = 80 mm
 18,5 cm - 7 1/4"
07.27.18



Cushing (Taylor)



a



a = 95 mm
 18,5 cm - 7 1/4"
07.26.68



Cushing (Taylor) "HM"

"HM"

Hartmetall
 Tungsten carbide
 Carburo de tungsteno
 Carbure de tungstène
 Carburo di tungsteno



mit Dissektorende
 with dissector end
 con extremo sirviendo de legra
 avec extrémité dissecteur
 con la parte finale a forma di dissettore

Kein Anhaften von Biogewebe ◀
 Schnelle Wärme- und Stromableitung ◀
 Einfache Reinigung ◀

No adhesion of biological tissue ◀
 Quick discharge of heat and current ◀
 Easy to clean ◀

Ninguna adherencia del tejido ◀
 Derivación rápida del calor y la corriente ◀
 Mantenimiento fácil ◀

Les tissus ne collent pas à la pince ◀
 Conductivité rapide et sûre de la chaleur et de l'électricité ◀
 Entretien facile ◀

Non aderisce ai tessuti biologici ◀
 Derivazione rapida del calore e della corrente elettrica ◀
 Pulizia facile ◀

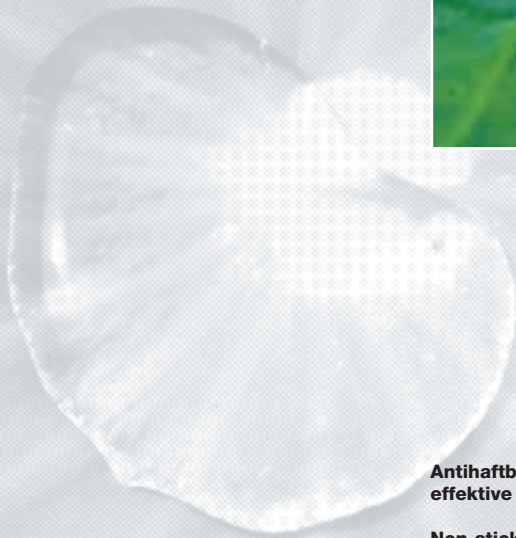

Antihaftbeschichtung sorgt für eine effektive Koagulation

Non-stick coating assures an effective coagulation

El recubrimiento no adherente permite una coagulación eficaz

Grâce à ses pointes anti-adhésives, la pince bipolaire permet une meilleure coagulation

Il rivestimento antiaderente permette una coagulazione effettiva

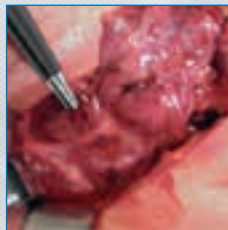



A04

Bipolare Antihaft-Pinzetten
Bipolar Non-stick Forceps
Pinzas bipolares no adherentes
Pinces bipolaires anti-adhésives
Pinze bipolari antiaderenti





0,6 mm	1,0 mm	
15 cm – 6"	15 cm – 6"	
88.07.02	88.07.03	
0,6 mm	1,0 mm	
18 cm – 7 1/8"	18 cm – 7 1/8"	
88.07.07	88.07.08	
0,6 mm	1,0 mm	
20 cm – 8"	20 cm – 8"	
88.07.12	88.07.13	



1,3 mm	
20 cm – 8"	
88.07.14	
2,0 mm	
20 cm – 8"	
88.07.15	

Juwelierpinzetten
 Jeweler's forceps
 Pinzas para joyero/relojero
 Pinces pour joaillier/horloger
 Pinze per gioielliere/orologiaio



0,25 mm	0,6 mm	1,0 mm
11 cm – 4 3/8"	11 cm – 4 3/8"	11 cm – 4 3/8"
88.07.81	88.07.82	88.07.83



spitz
sharp
aguda
pointu
acuta



stumpf
blunt
roma
mousse
smussa

Bipolare Antihaft-Pinzetten
Bipolar Non-stick Forceps
Pinzas bipolares no adherentes
Pinces bipolaires anti-adhésives
Pinze bipolari antiaderenti

A04



2,0 mm

22 cm – 8³/₄"

88.07.20

1,0 mm

24 cm – 9¹/₂"

88.07.23



0,3 mm

18 cm – 7¹/₈"

88.07.56

0,6 mm

18 cm – 7¹/₈"

88.07.57

1,0 mm

18 cm – 7¹/₈"

88.07.58

Juwelierpinzetten
 Jeweler's forceps
 Pinzas para joyero/relojero
 Pinces pour joaillier/horloger
 Pinze per gioielliere/orologiaio



0,25 mm	0,6 mm	1,0 mm
11 cm – 4 ³ / ₈ "	11 cm – 4 ³ / ₈ "	11 cm – 4 ³ / ₈ "
88.07.91	88.07.92	88.07.93



spitz
 sharp
 aguda
 pointu
 acuta



stumpf
 blunt
 roma
 mousse
 smussa



A04

Bipolare Antihaft-Pinzetten
Bipolar Non-stick Forceps
Pinzas bipolares no adherentes
Pinces bipolaires anti-adhésives
Pinze bipolari antiaderenti

Bajonettpinzetten
 Bayonet forceps
 Pinzas en forma bayoneta
 Pinces en forme baïonnette
 Pinze a forma baionetta



0,3 mm	0,6 mm	1,0 mm	1,3 mm	2,0 mm
a = 100 mm 20 cm – 8"	a = 100 mm 20 cm – 8"	a = 100 mm 20 cm – 8"	a = 100 mm 20 cm – 8"	a = 100 mm 20 cm – 8"
88.08.01	88.08.02	88.08.03	88.08.04	88.08.05
0,3 mm	0,6 mm	1,0 mm	1,3 mm	2,0 mm
a = 130 mm 22 cm – 8¾"	a = 130 mm 22 cm – 8¾"	a = 130 mm 22 cm – 8¾"	a = 130 mm 22 cm – 8¾"	a = 130 mm 22 cm – 8¾"
88.08.06	88.08.07	88.08.08	88.08.09	88.08.10
0,3 mm	0,6 mm	1,0 mm	1,3 mm	2,0 mm
a = 150 mm 24 cm – 9½"	a = 150 mm 24 cm – 9½"	a = 150 mm 24 cm – 9½"	a = 150 mm 24 cm – 9½"	a = 150 mm 24 cm – 9½"
88.08.11	88.08.12	88.08.13	88.08.14	88.08.15



spitz
sharp
aguda
pointu
acuta



stumpf
blunt
roma
mousse
smussa

Bipolare Antihaft-Pinzetten
Bipolar Non-stick Forceps
Pinzas bipolares no adherentes
Pinces bipolaires anti-adhésives
Pinze bipolari antiaderenti

A04

Bajonettpinzetten
 Bayonet forceps
 Pinzas en forma bayoneta
 Pinces en forme baïonnette
 Pinze a forma baionetta



0,3 mm	0,6 mm	1,0 mm
a = 80 mm 18 cm – 7 1/8"	a = 80 mm 18 cm – 7 1/8"	a = 80 mm 18 cm – 7 1/8"
88.08.91	88.08.92	88.08.93

0,3 mm	0,6 mm	1,0 mm
a = 100 mm 20 cm – 8"	a = 100 mm 20 cm – 8"	a = 100 mm 20 cm – 8"
88.08.71	88.08.72	88.08.73

0,3 mm	0,6 mm
a = 120 mm 22 cm – 8 3/4"	a = 120 mm 22 cm – 8 3/4"
88.08.76	88.08.77

0,3 mm	0,6 mm
a = 140 mm 24 cm – 9 1/2"	a = 140 mm 24 cm – 9 1/2"
88.08.81	88.08.82

spitz
sharp
aguda
pointu
acuta

stumpf
blunt
roma
mousse
smussa



A04

Bipolare Anschlusskabel und Halteklammer
Bipolar Connecting Cables and Bracket
Cables de conexión bipolar y dispositivo
Câbles connecteurs bipolaires et dispositif
Cavi di connessione bipolari e dispositivo di tenuta

Stecker für Instrumente (siehe Seite 28-31)
 Connector for instruments (see page 28-31)
 Enchufe para instrumentos (véase página 28-31)
 Fiche pour instruments (voir page 28-31)
 Attacco per strumenti (vedi pagina 28-31)

Stecker für Geräte von:
 Connector for generator of:
 Enchufe para equipos de:
 Fiche pour appareils de:
 Attacco per apparecchi:

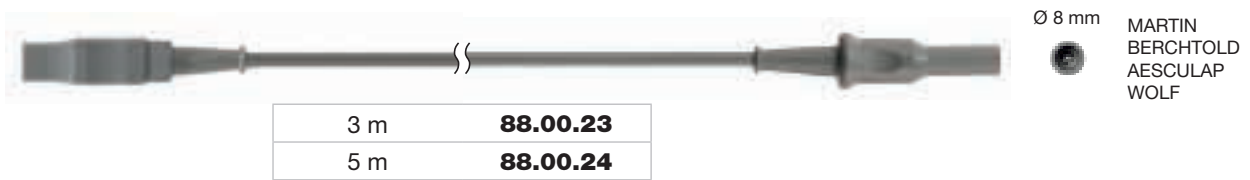
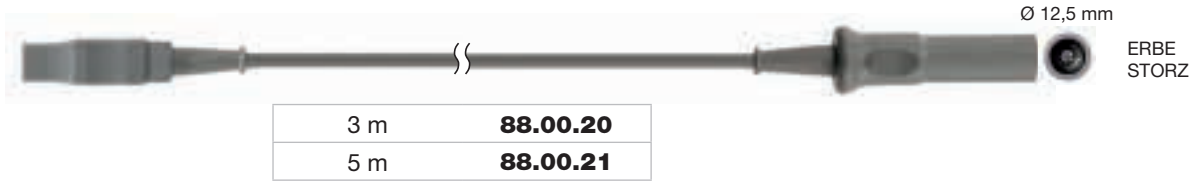

Halteklammer für ein Hochfrequenzkabel mit Knickschutz
Bracket for one high frequency cable with bend protection
Dispositivo para un cable de alta frecuencia con protección contra pliegues de cables
Dispositif pour un câble à haute fréquence avec protection contre plis de câble
Dispositivo di tenuta per un cavo ad alta frequenza con protezione antipiega

- ▶ Passend für Siebkörbe ab ½-Container
- ▶ Sicherheitsverschluss dient auch als Haltegriff
- ▶ Verwendbar für alle Hochfrequenzkabel

- ▶ Suitable for wire baskets starting from ½ container
- ▶ Safety lock serves as handle
- ▶ Suitable for all high frequency cables

- ▶ Aptos para bandejas a partir de ½ contenedor
- ▶ Cierre de seguridad sirve también de mango
- ▶ Utilizable para todos los cables de alta frecuencia

- ▶ Approprié pour paniers à partir de ½ container
- ▶ Fermoir de sécurité utilisable comme manche
- ▶ Approprié pour tous types de câbles à haute fréquence

- ▶ Adatto per cestelli da ½ contenitore
- ▶ Chiusura di sicurezza utilizzabile anche come manico
- ▶ Adatto a tutti i cavi di alta frequenza



22,5 cm - 9" **88.00.40**



“HM”

Nadelhalter mit Hartmetalleinlagen
Needle holders with tungsten carbide inserts
Porta-agujas con plaquitas de carburo de tungsteno
Porte-aiguilles avec mors en carbure de tungstène
Portaghi con placchette di carburo di tungsteno

N 0,5 mm

normal
regular
normal
normale
normale

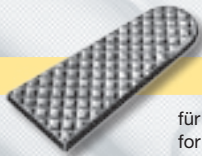

für Nadeln und Nahtmaterial bis Stärke 4-0
for needles and sutures up to size 4-0
para agujas y material de sutura hasta el espesor de 4-0
pour aiguilles et matériel à suture jusqu'à une épaisseur de 4-0
per aghi e materiale per sutura fino ad uno spessore di 4-0

F 0,4 mm

fein
fine
fino
fine
fine

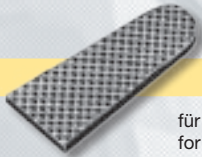

für feine Nadeln und Nahtmaterial in der Stärke 5-0 und 6-0
for delicate needles and sutures sizes 5-0 and 6-0
para agujas finas y material de sutura para espesores 5-0 y 6-0
pour aiguilles fines et matériel à suture d'une épaisseur de 5-0 et 6-0
per aghi fini e materiale per sutura fino ad uno spessore di 5-0 e 6-0

EF 0,3 mm

extra-fein
extra-fine
extra-fino
extra-fine
extra-fine

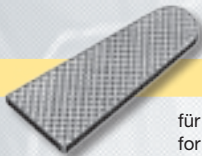

für Mikro-Nadeln und Nahtmaterial bis Stärke 10-0
for micro-needles and sutures up to size 10-0
para micro-agujas y material de sutura hasta el espesor de 10-0
pour micro-aiguilles et matériel à suture jusqu'à une épaisseur de 10-0
per aghi micro e materiale per sutura fino ad uno spessore di 10-0

glatt
smooth
liso
lisse
liscia

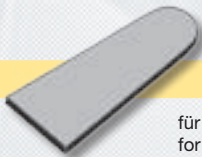

für feine Nadeln und Nahtmaterial in der Stärke 7-0 bis 10-0
for delicate needles and sutures from sizes 7-0 to 10-0
para agujas finas y material de sutura para espesores 7-0 y 10-0
pour aiguilles fines et matériel à suture d'une épaisseur de 7-0 à 10-0
per aghi fini e materiale per sutura fino ad uno spessore di 7-0 fino a 10-0



A05

Nadelhalter
Needle Holders
Porta-agujas
Porte-aiguilles
Portaghi

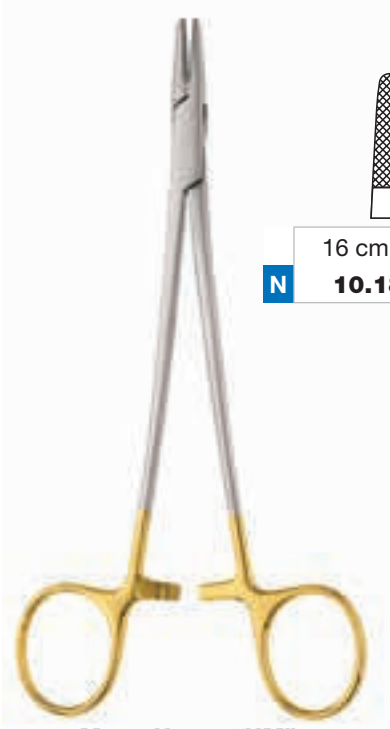

Mayo-Hegar "HM"

N

16 cm – 6¼"
10.18.65

18 cm – 7⅛"
10.18.68

20 cm – 8"
10.18.70

23 cm – 9"
10.18.73

N

24 cm – 9½"
10.18.74

26 cm – 10¼"
10.18.76

30 cm – 11¾"
10.18.80

Ti



Mayo-Hegar "HM"

N

16 cm – 6¼"
10.18.85

18 cm – 7⅛"
10.18.88

20 cm – 8"
10.18.90

23 cm – 9"
10.18.93

"HM"



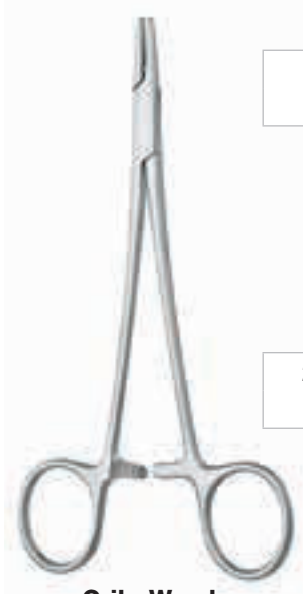

Hartmetall
Tungsten carbide
Carburo de tungsteno
Carbure de tungstène
Carburo di tungsteno

Ti

Titan
Titanium
Titanio
Titane
Titano



Crile-Wood

	
15 cm – 6" 10.20.15	18 cm – 7 1/8" 10.20.18
	
20 cm – 8" 10.20.20	23 cm – 9" 10.20.23









Baby-Crile-Wood "HM"

F 15 cm – 6" 10.20.64



**Crile-Wood "HM"
(DeBakey "HM")**

			
F 15 cm – 6" 10.20.65	18 cm – 7 1/8" 10.20.68	20 cm – 8" 10.20.70	23 cm – 9" 10.20.73
			
F 25 cm – 10" 10.20.75	26 cm – 10 1/4" 10.20.76	30 cm – 11 3/4" 10.20.80	

"HM"

Hartmetall
Tungsten carbide
Carburo de tungsteno
Carbure de tungstène
Carburo di tungsteno

F

5-0 and 6-0

fein
fine
fino
fine
fine



A05

Nadelhalter
Needle Holders
Porta-agujas
Porte-aiguilles
Portaghi



micro-slim "HM"

F



15 cm - 6"
10.24.65



18 cm - 7 1/8"
10.24.68



20 cm - 8"
10.24.70



23 cm - 9"
10.24.73



15 cm - 6"
10.24.66



18 cm - 7 1/8"
10.24.69



20 cm - 8"
10.24.71

mit Schere
with scissors
con tijera
avec ciseaux
con forbice



Gillies "HM"



F

15,5 cm - 6 1/8"
10.59.65

7-0 to 10-0
glatt
smooth
liso
lisse
liscia

N
4-0
normal
regular
normal
normale
normale

"HM"
Hartmetall
Tungsten carbide
Carburo de tungsteno
Carbure de tungstène
Carburo di tungsteno



Mathieu "HM"



14 cm – 5½"

N

11.20.64



17 cm – 6¾"

11.20.67



20 cm – 8"

11.20.70



24 cm – 9½"

11.20.74



Mathieu "HM"



14 cm – 5½"

N

11.22.64



17 cm – 6¾"

11.22.67



20 cm – 8"

11.22.70

N
4-0
normal
regular
normal
normale
normale

"HM"
Hartmetall
Tungsten carbide
Carburo de tungsteno
Carbure de tungstène
Carburo di tungsteno



A05

Mikro-Nadelhalter
Micro Needle Holders
Micro porta-agujas
Micro porte-aiguilles
Micro portaghi

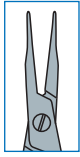

0,4 mm	0,4 mm	0,5 mm	0,5 mm
18 cm – 7 1/8"	18 cm – 7 1/8"	18 cm – 7 1/8"	18 cm – 7 1/8"
12.18.66	12.18.67	12.18.68	12.18.69

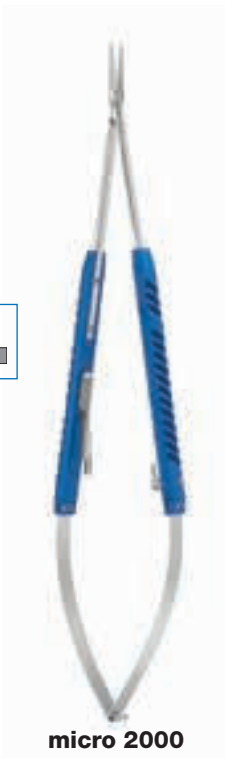

18 cm – 7 1/8"	18 cm – 7 1/8"
12.18.74	12.18.75



Instrumente mit blau eloxierten Leichtmetall-Griffen für höchste Präzision und Arbeitskomfort.

Instruments with blue anodized light metal handles for maximum precision and working convenience.

Instrumentos con mangos de metal ligero anodizados en azul para la precisión y el confort de trabajo máximo.

Instrumentes avec manches en métal léger anodisés en bleu pour un maximum de précision et de confort à l'utilisation.

Strumenti con manici di metallo leggero anodizzati blu, che permette una precisione massima e un confort lavorativo.

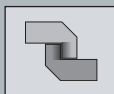

mit Sperre
with catch
avec crémaillère
con cremagliera



Beschichtung mit Diamantstaub
Coating with diamond dust
Recubierto con polvo de diamante
Revêtement avec de poussière de diamant
Rivestito con polvere di diamante



Rundgriff
Round handle
Mango redondo
Manche rond
Manico rotondo

Konisches Saugrohr verhindert ein Verstopfen der Kanüle
 Bajonettverschluss für schnellen Kanülenwechsel
 Einfache Zerlegbarkeit für optimale Reinigung

Conical suction tube prevents clogging of the cannula
 Bayonet joint for quick cannula changes
 Easy dismantling for best possible cleaning

La cánula cónica de succión evita la obstrucción de la misma
 Cierre de bayoneta para el cambio rápido de las cánulas
 Fácil desmontaje para una limpieza óptima

Un tuyau conique prévient le colmatage de la canule
 Fermeture de type baïonnette pour un remplacement rapide de la canule
 Démontage facile pour un nettoyage optimal

Cannule d'aspirazione coniche per evitare che si otturino
 Attacco a baionetta per una rapida sostituzione della cannula
 Facile da smontare per una pulizia ottimale



Progressive und ergonomische Regulierung der Saugkraft
Progressive and ergonomic adjustment of the suction power
Regulación progresiva y ergonómica de la potencia de aspiración
Réglage progressif et ergonomique de la puissance d'aspiration
Regolazione progressiva ed ergonomica dell'intensità d'aspirazione

entwickelt in Zusammenarbeit mit:
 developed in cooperation with:
 desarrollado en colaboración con:
 développée en collaboration avec:
 sviluppato in collaborazione con:

Prof. Marco Cenzato
 Head of Department Neuro Surgery
 Hospital Niguarda Ca' Granda - Milan



A06

Saug- und Spülinstrumente
Suction and Irrigating Instruments
Instrumentos de aspiración y de lavado
Instrumenti à aspiration et à irrigation
Strumenti per aspirazione e lavaggio

P ♦ E ♦ N

Handgriff mit drehbarem Schlauchansatz
 Handle with rotatable tube connection
 Mango con empalme giratorio para tubo
 Manche avec embout de tuyau pivotant
 Manico con attacco girevole per tubo

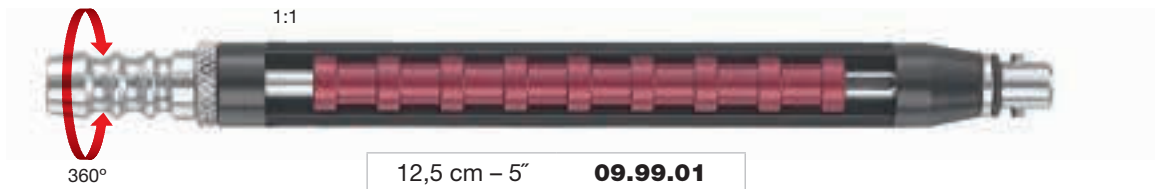

Saugkanülen (biegbar)
 Suction cannulas (malleable)
 Cánulas de aspiración (maleables)
 Canules à aspiration (malléables)
 Cannule per aspirazione (malleabili)

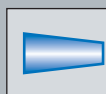
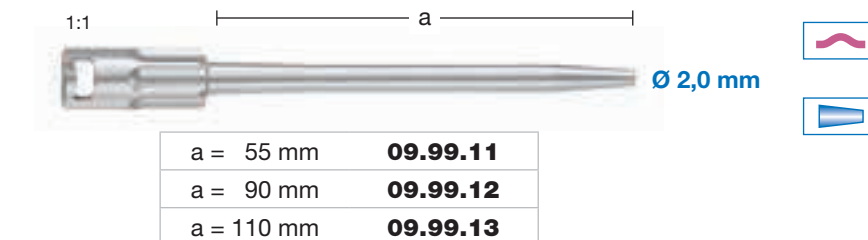
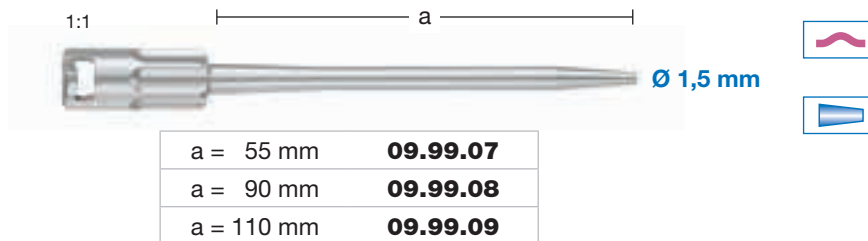

Saugkanülenrohre sind konisch
 Conical shape of the suction cannulas
 Forma cónica de la cánulas
 Canules de forme conique
 Cannule di forma conica



biegbar
 malleable
 maleables
 malléables
 malleabili

P ♦ E ♦ N

Adapter für Einweg-Saugkanülen mit Steckverbindung
 Adapter for disposable suction cannulas with plug-in connection
 Adaptador para cánulas de aspiración desechable con conexión "plug-in"
 Adaptateur pour canules à aspiration à usage unique avec connecteur rapide
 Adattatore per cannule d'aspirazione monouso con connessione "plug-in"



Ersatz-O-Ring
 Replacement O-ring
 Anillo tórico de repuesto
 Joint torique de rechange
 Guarnizione ad anello di ricambio





A06

Saug- und Spülinstrumente
Suction and Irrigating Instruments
Instrumentos de aspiración y de lavado
Instrumenti à aspiration et à irrigation
Strumenti per aspirazione e lavaggio

Knopfkannülen
 Cannulas with olive
 Cánulas con oliva
 Canules avec olive
 Cannule con oliva

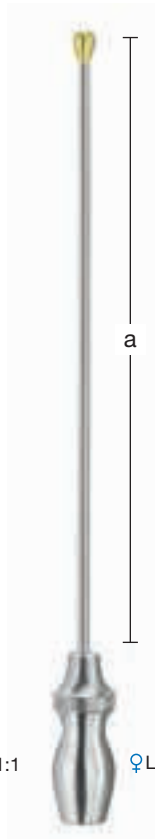

1:1 ♀ Luer

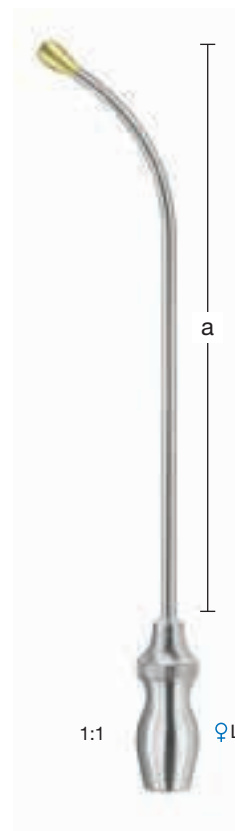

1:1 ♀ Luer

	a = 80 mm
Ø 1,0 mm	09.79.70
Ø 1,2 mm	09.79.71
Ø 1,4 mm	09.79.72
Ø 1,5 mm	09.79.73
Ø 1,6 mm	09.79.74
Ø 1,8 mm	09.79.75
Ø 2,0 mm	09.79.76

	a = 75 mm
Ø 1,8 mm	09.79.85

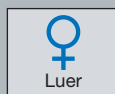

Schlauchverbindung (weiblich)
 Tube connection (female)
 Conexión de tubo (femenina)
 Raccord de tuyau (féminine)
 Raccordo per tubo (femminile)

Saugkanülen
Suction cannulas
Cánulas de aspiración
Canules à aspiration
Cannule per aspirazione

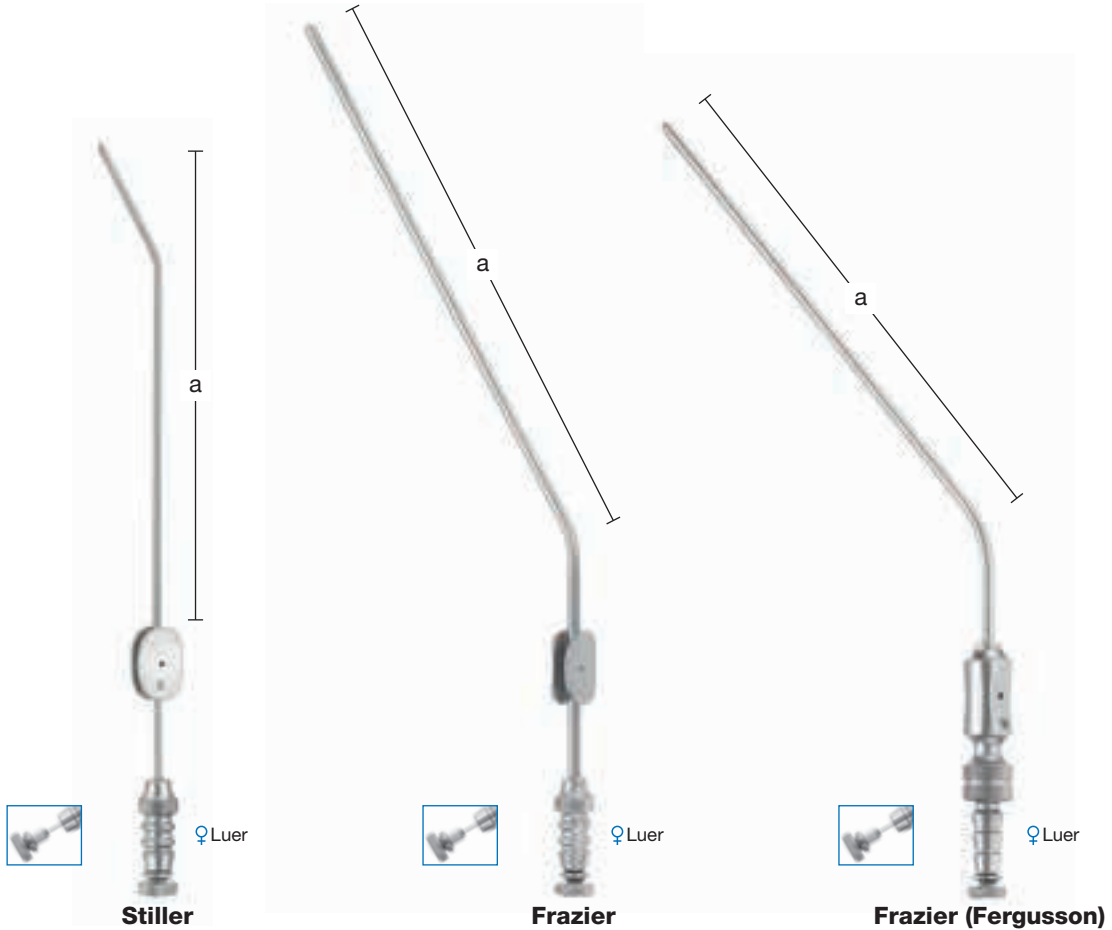

Stiller

a = 125 mm

Charr. 6	09.83.07
----------	-----------------

Frazier

a = 180 mm

Charr. 6	09.83.56
Charr. 8	09.83.58
Charr. 10	09.83.60
Charr. 12	09.83.62

Frazier (Fergusson)

a = 180 mm

Charr. 3	09.83.73
Charr. 6	09.83.76
Charr. 8	09.83.78
Charr. 10	09.83.80
Charr. 12	09.83.82

 Schlauchverbindung (weiblich)
Tube connection (female)
Conexión de tubo (femenina)
Raccord de tuyau (féminine)
Raccordo per tubo (femminile)

 mit Mandrin
with guide
con mandril
avec mandrin
con mandrino



A06

Saug- und Spülinstrumente
Suction and Irrigating Instruments
Instrumentos de aspiración y de lavado
Instrumenti à aspiration et à irrigation
Strumenti per aspirazione e lavaggio

Saugelevatorium
 Suction elevator
 Elevador aspirador
 Elévateur aspirateur
 Elevatore con aspirazione

Schlauchansatz, drehbar
 Tube connection, rotatable
 Empalme de tubo, giratorio
 Embout de tuyau, rotatif
 Attacco per tubo, girevole



Haraldsson

- ▶ Mit drehbarem Schlauchansatz und Bleistiftgriff - für ein komfortables Arbeiten.
- ▶ Die gerundete Spitze verletzt nicht den Knorpel, ermöglicht aber eine präzise, subperichondrale Präparation.
- ▶ With rotating tube connection and pencil grip - for comfortable operation.
- ▶ The rounded tip does not damage the cartilage but enables a precise subperichondrial preparation.
- ▶ Con empalme de tubo giratorio y mango en forma de lápiz - para trabajar de forma más cómoda.
- ▶ La punta redondeada no daña el cartilago, pero permite una disección subpericondril precisa.
- ▶ Avec embout de tuyau rotatif et manche crayon - pour un travail confortable.
- ▶ La pointe arrondie n'endommage pas le cartilage, et permet une préparation sous-périchondrale précise.
- ▶ Con attacco girevole per tubo girevole e manico a matita - per la massima comodità di lavoro.
- ▶ La punta arrotondata non danneggia la cartilagine, ma consente una precisa preparazione subpericondrile.

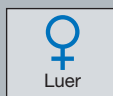

Schlauchverbindung (weiblich)
 Tube connection (female)
 Conexión de tubo (femenina)
 Raccord de tuyau (féminine)
 Raccordo per tubo (femminile)

Myrtenblattsonden
Myrtle leaf probes
Estiletes hoja de mirto
Stylets feuille de myrte
Specilli a foglia di mirto



1:1

13,0 cm – 5 1/8"	09.08.13
14,5 cm – 5 3/4"	09.08.14
16,0 cm – 6 1/4"	09.08.16
20,0 cm – 8"	09.08.20

mit Ohr
with eye
con ojete
avec chas
con ansa



1:1

13,0 cm – 5 1/8"	09.10.13
14,5 cm – 5 3/4"	09.10.14
16,0 cm – 6 1/4"	09.10.16
20,0 cm – 8"	09.10.20

mit Ohr
with eye
con ojete
avec chas
con ansa



1:1

Mod.USA

rostfrei
stainless steel
inoxidable
inoxydable
inossidabile

13,0 cm – 5 1/8"	09.11.13
14,5 cm – 5 3/4"	09.11.14
15,0 cm – 6"	09.11.15
18,0 cm – 7 1/8"	09.11.18
20,0 cm – 8"	09.11.20



A07

**Sonden
Probes
Estiletos
Stylets
Specilli**

Hohlsonden
Directors
Sondas acanaladas
Sondes cannelées
Specilli scanalati



1:1



11,5 cm – 4½"	09.15.11
14,5 cm – 5¾"	09.15.14
16,0 cm – 6¼"	09.15.16
18,0 cm – 7⅛"	09.15.18
20,0 cm – 8"	09.15.20

1:1

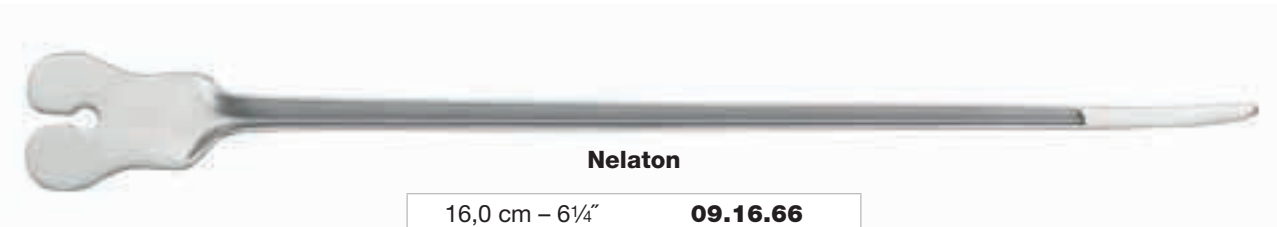

Nelaton

16,0 cm – 6¼"	09.16.66
---------------	-----------------

Watteträger
Cotton carriers
Porta-algodones
Porte-coton
Portacotone

spiralförmig
spiral threads
estrias espirales
striure en spirale
striatura a spirale

1:1

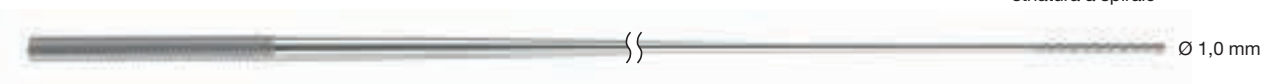

Frohn

12,0 cm – 4¾"	09.20.12
14,0 cm – 5½"	09.20.14
16,0 cm – 6¼"	09.20.16

Tränenkanalsonden aus Silber
Lacrimal probes out of sterling silver
Sondas exploradoras para canal lagrimal de plata pura
Sondes exploratrices pour le canal lacrymal en argent pur
Sonde esploratrici per canale lacrimale in argento puro



Bowman

# 0000 / 000	60.34.10
# 00 / 0	60.34.11
# 1 / 2	60.34.12
# 3 / 4	60.34.14
# 5 / 6	60.34.16
# 7 / 8	60.34.18



Bowman (Williams)

# 00 / 0	60.34.31
# 1 / 2	60.34.32
# 3 / 4	60.34.34
# 5 / 6	60.34.36
# 7 / 8	60.34.38

Größenskala für Sonden
Size scale for probes
Escala comparativa para sondas
Echelle comparative pour sondes
Scala comparativa per sonde

#	0000	000	00	0	1	2	3	4	5	6	7	8
Ø (mm)	0,6	0,7	0,8	0,9	1,0	1,1	1,2	1,3	1,4	1,5	1,6	1,7

medicon-cat OMF

Wir unterstützen unsere Kunden auch mit Vertriebstools wie Literatur und CDs.

We also assist our clients with sales tools like literature and CDs.

También apoyamos a nuestros clientes con herramientas de venta como literatura y CDs.



Nous supportons également nos clients avec des outils de vente comme la littérature et CD.

Assistiamo i nostri clienti anche con utensili di vendita come la letteratura e CD.



1:1





 3,8 cm – 1½" 15.10.38	 5,1 cm – 2" 15.10.51
--	---

Dieffenbach

1:1





 3,8 cm – 1½" 15.11.38	 5,1 cm – 2" 15.11.51
--	---

Dieffenbach

1:1





 3,5 cm – 1⅛" 15.12.35	 5,5 cm – 2⅛" 15.12.55
--	--

Dieffenbach

1:1



 3,5 cm – 1⅛" 15.13.35	 5,5 cm – 2⅛" 15.13.55
--	--

Dieffenbach



A08

Arterienklemmen
 Hemostatic Forceps
 Pinzas hemostáticas
 Pinces hémostatiques
 Pinze emostatiche



**Hartmann
(Baby-Mosquito)**



10 cm – 4"
15.32.09



10 cm – 4"
15.33.09



Providence-Hospital



14 cm – 5½"
15.50.14



14 cm – 5½"
15.51.14



Kelly



14 cm – 5½"
15.70.14



14 cm – 5½"
15.71.14



Dandy



14 cm – 5½"
16.11.84



14 cm – 5½"
16.11.94

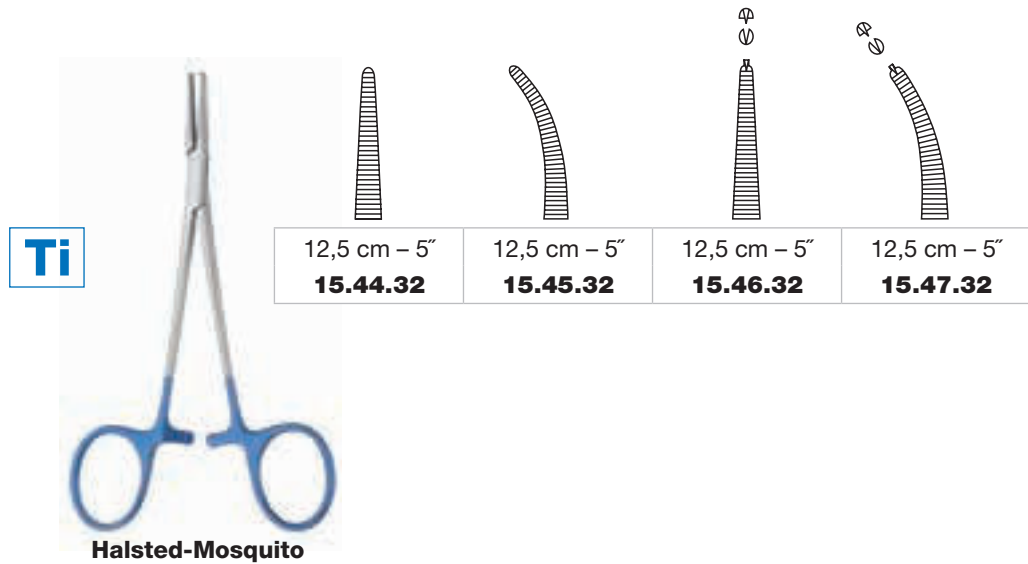
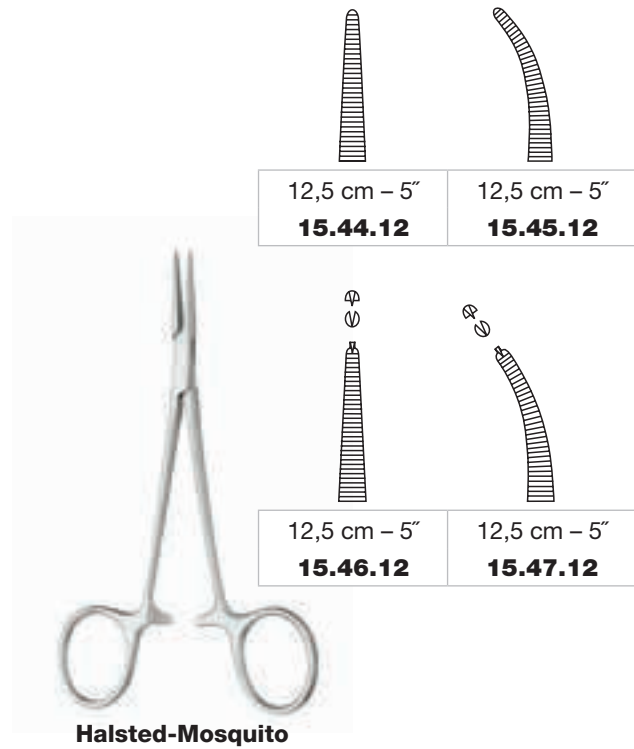
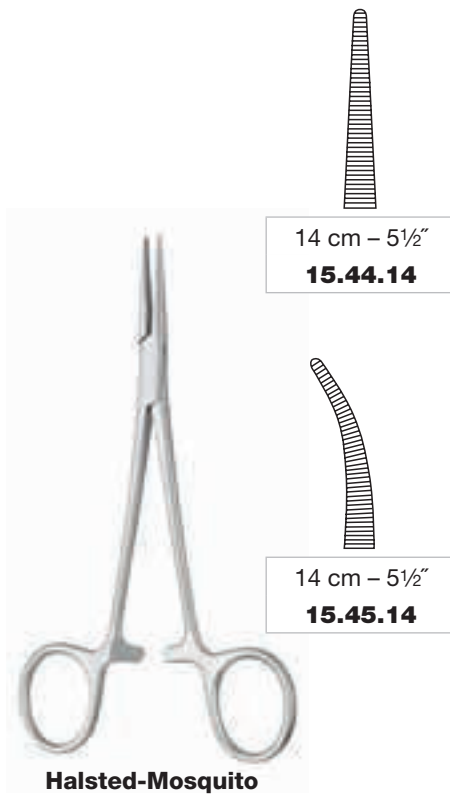



A08

Präparierklemmen und Tuchklemmen
Dissecting Forceps and Towel Clamps
Pinzas para disección y pinzas de campo
Pinces à dissection et pincès à champs
Pinze per dissezione e pinze fissateli



Präparierklemmen
 Dissecting forceps
 Pinzas para disección
 Pinces à dissection
 Pinze per dissezione



Adson-Baby

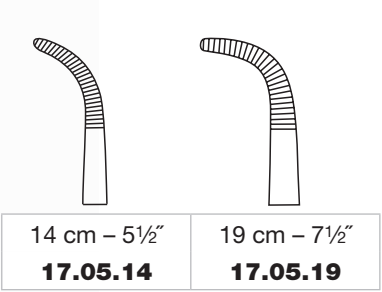

Tuchklemme
 Towel clamp
 Pinza de campo
 Pince à champs
 Pinza fissateli

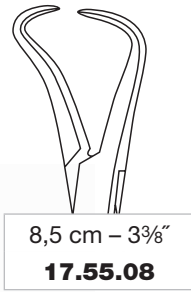

Tuchklemmen
 Towel clamps
 Pinzas de campo
 Pinces à champs
 Pinze fissateli

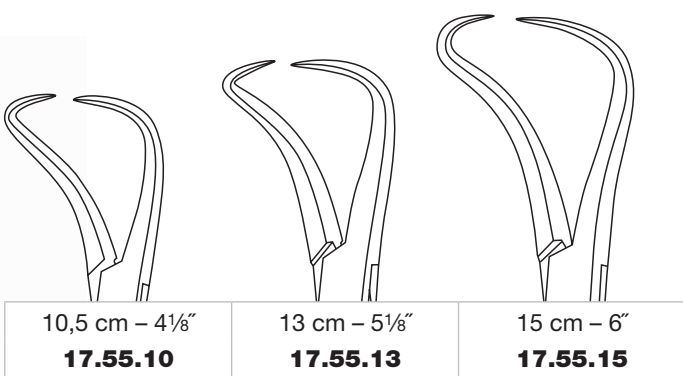
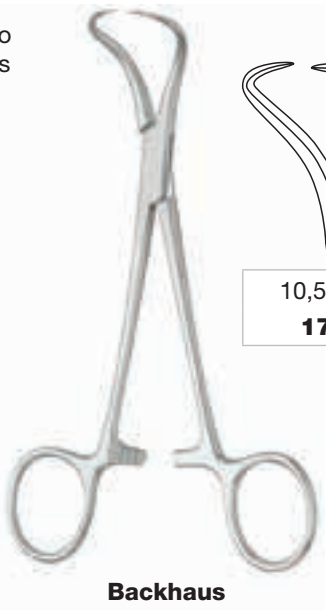

Tuchklemmen
Towel clamps
Pinzas de campo
Pinces à champs
Pinze fissateli

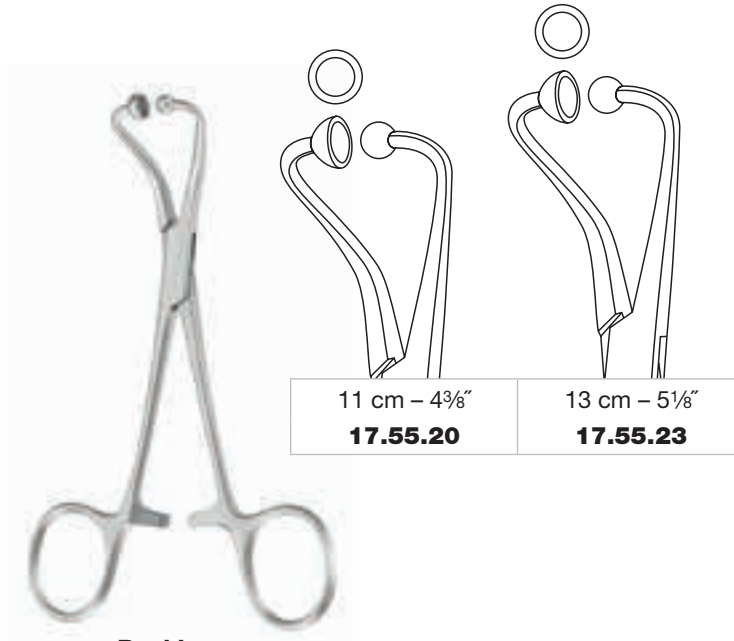

Backhaus
Ball and Socket



Backhaus-Roeder



A09

Kornzangen
Dressing Forceps
Pinzas para curaciones
Pinces à pansements
Pinze per medicazione



Gross



20 cm – 8"
19.14.20

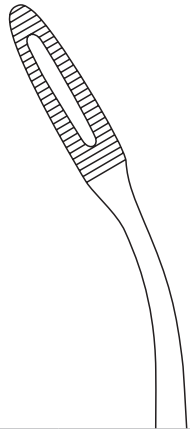

20 cm – 8"
19.15.20



Maier



26 cm – 10¼"
19.14.26



26 cm – 10¼"
19.15.26



Gross

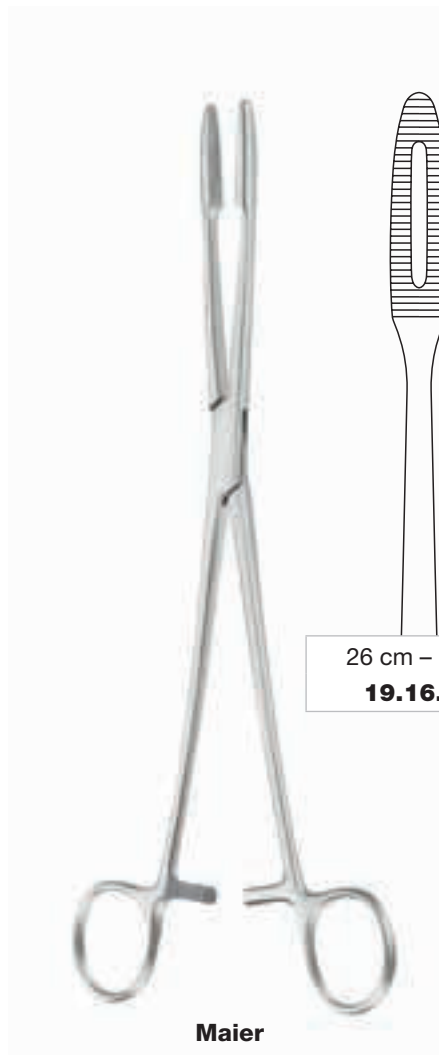
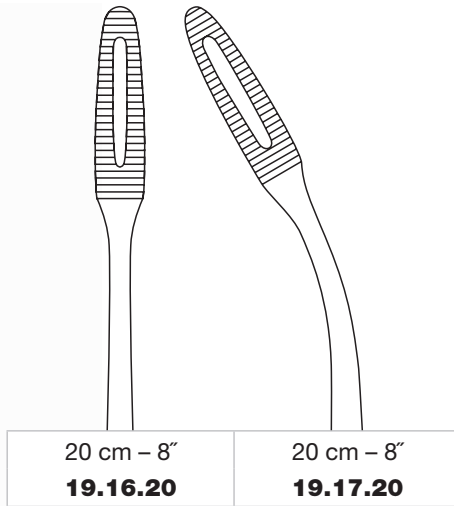

Maier

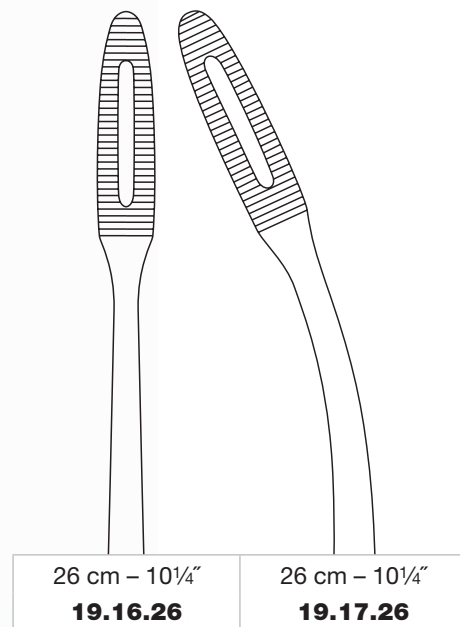

MEDICON

instruments

OMF - SURGERY

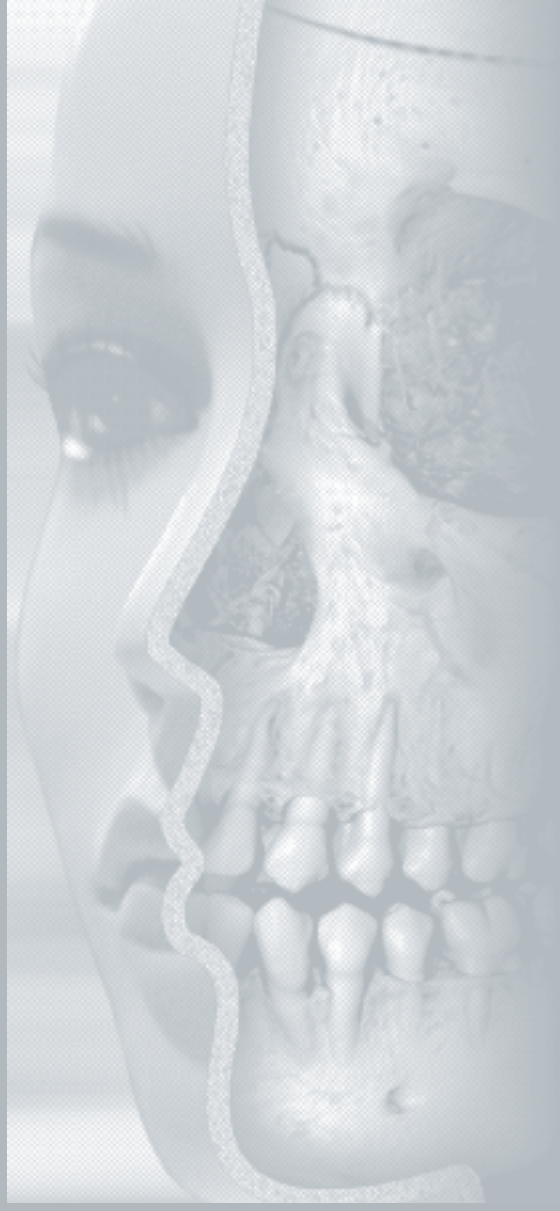



OMF INSTRUMENTS





B01





Feine Wundhaken
Delicate Retractors
Separadores finos
Ecarteurs fins
Divaricatori delicati



Nervhäkchen
 Nerve hooks
 Ganchitos para nervios
 Crochets à nerfs
 Uncini per nervi



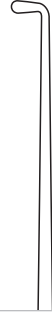

Cushing

			
4 mm	6 mm	4 mm	6 mm
19 cm - 7½"	19 cm - 7½"	28 cm - 11"	28 cm - 11"
20.22.31	20.22.32	20.22.36	20.22.37



Lucae

		
2 mm	3 mm	4 mm
14 cm - 5½"	14 cm - 5½"	14 cm - 5½"
20.22.01	20.22.02	20.22.03

Venenhaken
 Vein retractors
 Ganchos para venas
 Ecarteurs à veines
 Divaricatori per vene

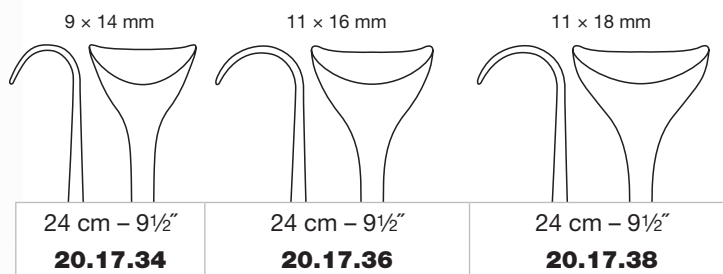
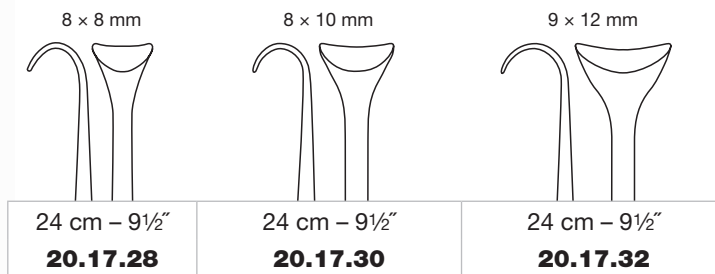
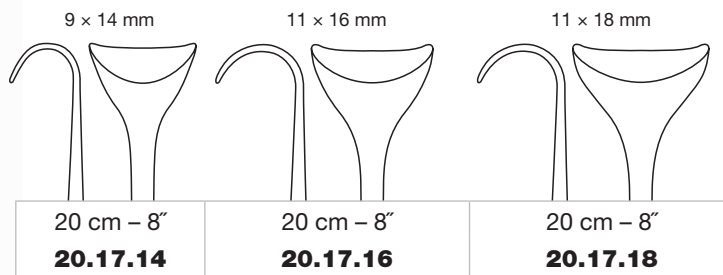
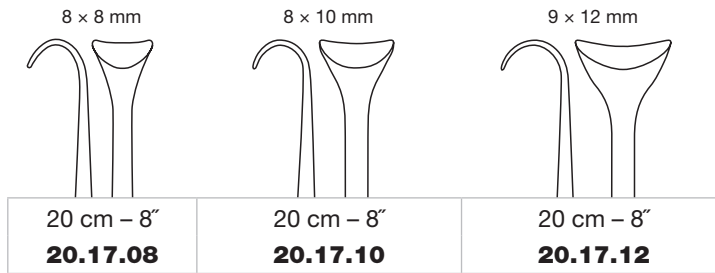



B01

Feine Wundhaken
Delicate Retractors
Separadores finos
Ecarteurs fins
Divaricatori delicati



Venenhaken
 Vein retractor
 Gancho para venas
 Ecarteur à veines
 Divaricatore per vene



Hauthäkchen
 Skin hooks
 Ganchitos para piel
 Crochets à peau
 Uncini per la cute

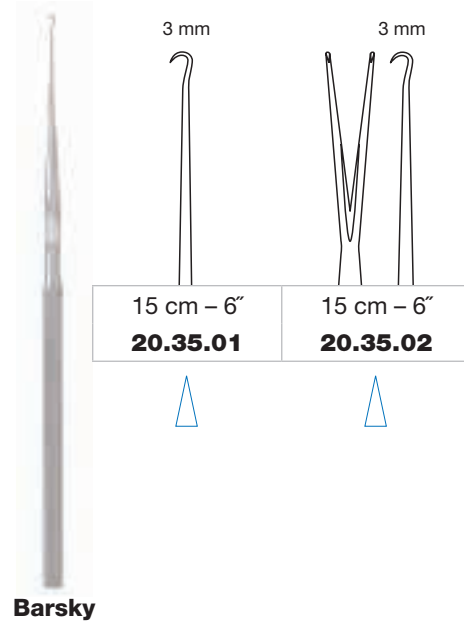

Hauthäkchen
 Skin hooks
 Ganchitos para piel
 Crochets à peau
 Uncini per la cute

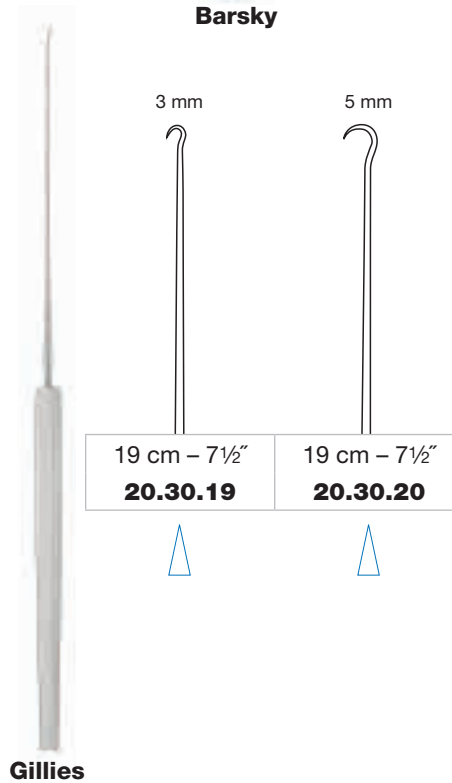
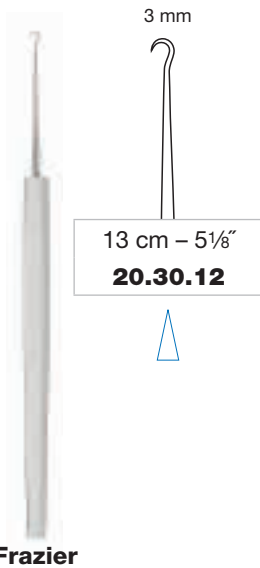

Das zweifach gebogene Arbeitsende ("S"-Form) ermöglicht eine freie Sicht auf das OP-Feld und erleichtert das Assistieren.

The double curved ("S"-form) working end enables a good sight on the operating field and facilitates the assistance.

El extremo de trabajo doble curvado (en forma "S") posibilita una buena visión sobre el campo operatorio y facilita la asistencia.

L'extrémité deux fois coudée (en forme de "S") permet une bonne vue sur le champs opératoire et simplifie aussi l'assistance.

L'estremità doppia curvata (forma di "S") rende possibile una migliore vista sul campo operatorio e facilita anche l'assistenza.



Benicke

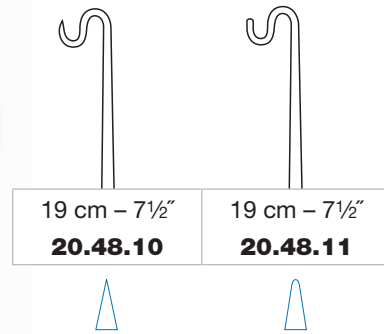

Senn-Miller

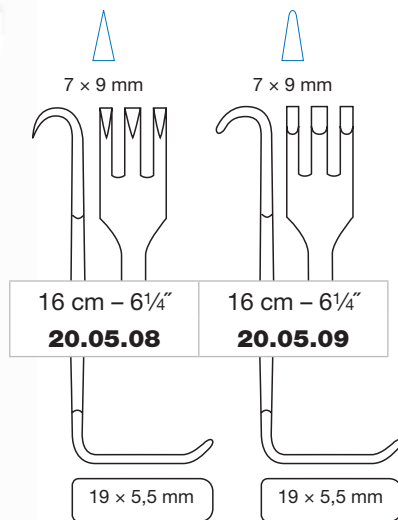

Joseph

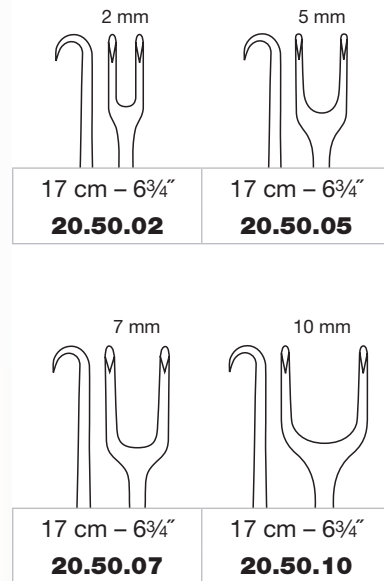

spitz
sharp
aguda
pointu
acuta



stumpf
blunt
roma
mousse
smussa



B01

Feine Wundhaken
Delicate Retractors
Separadores finos
Ecarteurs fins
Divaricatori delicati



Guthrie

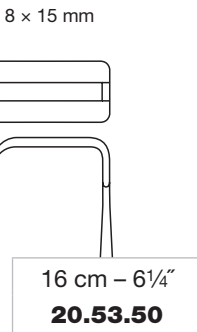
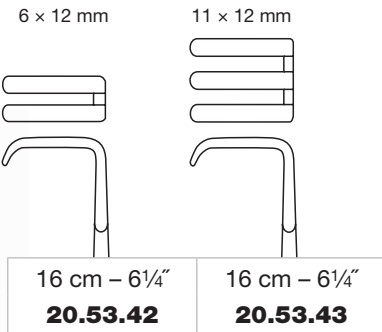
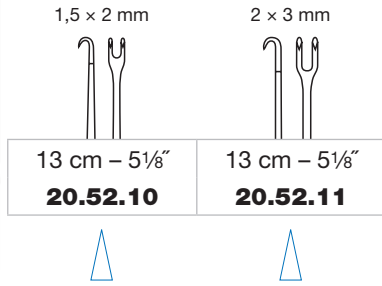



9 × 2 mm	9 × 8 mm	9 × 10 mm	9 × 14 mm
16 cm – 6¼"	16 cm – 6¼"	16 cm – 6¼"	16 cm – 6¼"
20.64.01	20.64.02	20.64.03	20.64.04



9 × 2 mm	9 × 8 mm	9 × 10 mm	9 × 14 mm
16 cm – 6¼"	16 cm – 6¼"	16 cm – 6¼"	16 cm – 6¼"
20.65.01	20.65.02	20.65.03	20.65.04



7 × 1 mm	7 × 5 mm	7 × 8 mm	7 × 11 mm
16 cm – 6¼"	16 cm – 6¼"	16 cm – 6¼"	16 cm – 6¼"
20.66.01	20.66.02	20.66.03	20.66.04



7 × 1 mm	7 × 5 mm	7 × 8 mm	7 × 11 mm
16 cm – 6¼"	16 cm – 6¼"	16 cm – 6¼"	16 cm – 6¼"
20.67.01	20.67.02	20.67.03	20.67.04



spitz
sharp
aguda
pointu
acuta

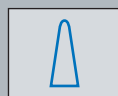

stumpf
blunt
roma
mousse
smussa



B01

Wundhaken
Retractors
Separadores
Ecarteurs
Divaricatori



Volkman

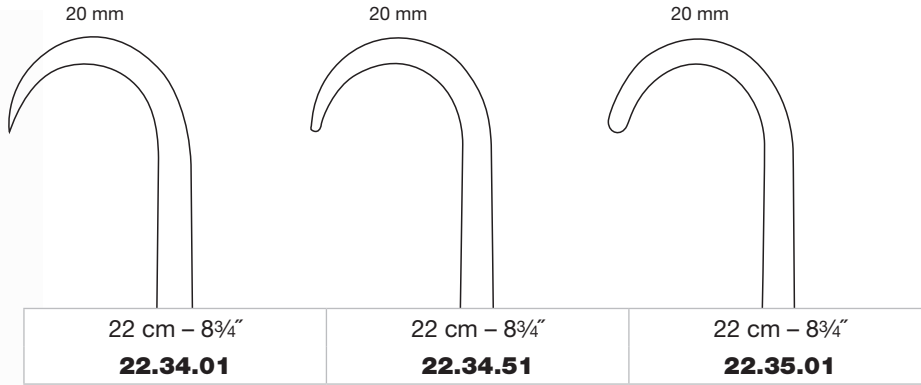

Kocher

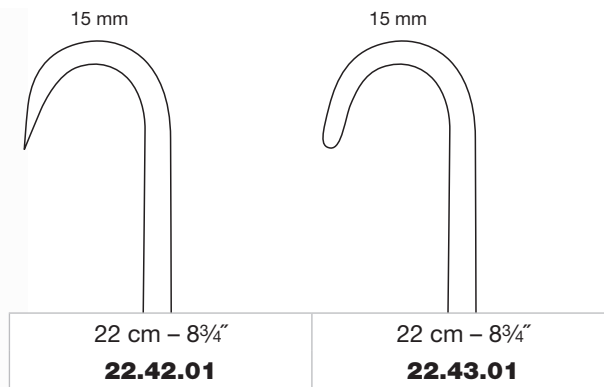

spitz
sharp
aguda
pointu
acuta

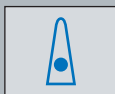

halbspitz
semi sharp
semi aguda
semi pointu
semi acuta



stumpf
blunt
roma
mousse
smussa

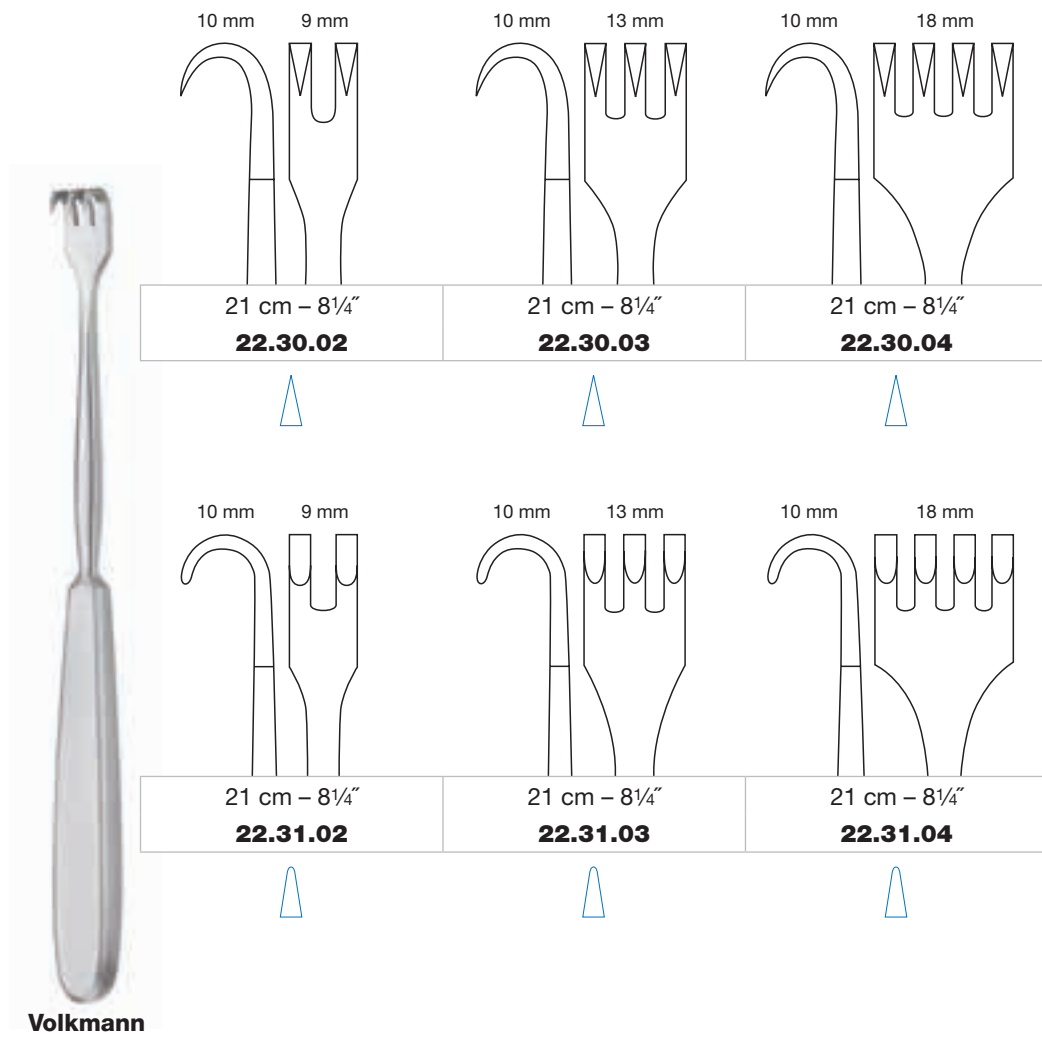

spitz
sharp
aguda
pointu
acuta

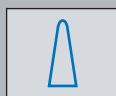

stumpf
blunt
roma
mousse
smussa



B01

Wundhaken
Retractors
Separadores
Ecarteurs
Divaricatori



Langenbeck

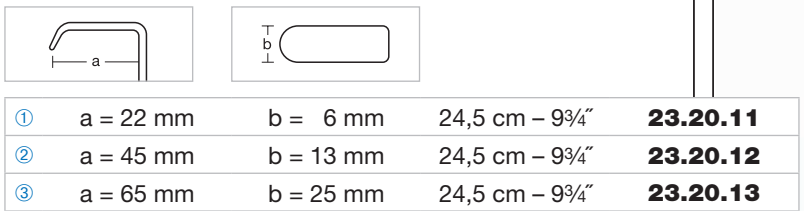
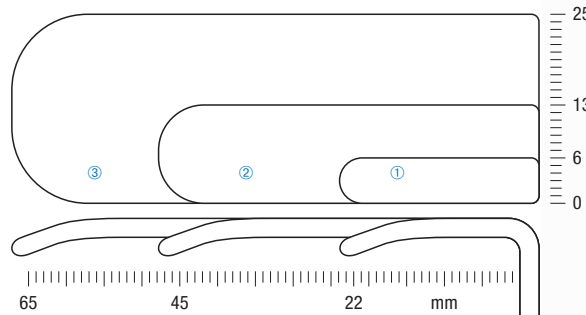
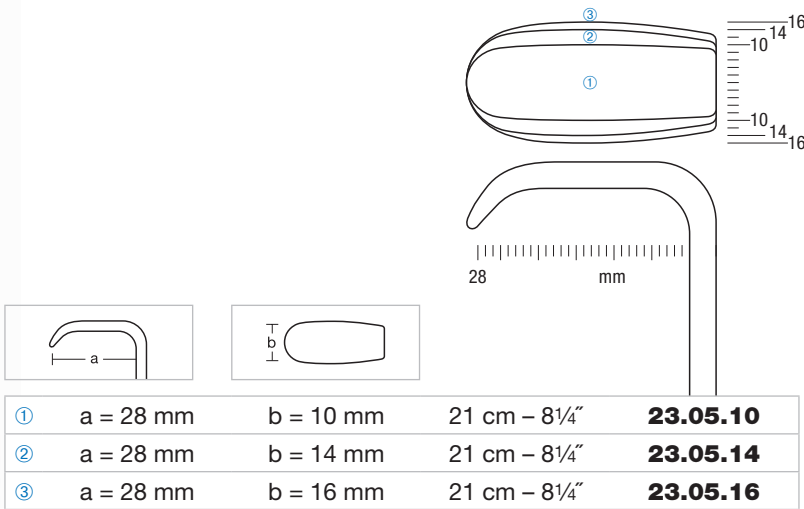



Kocher

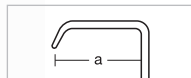
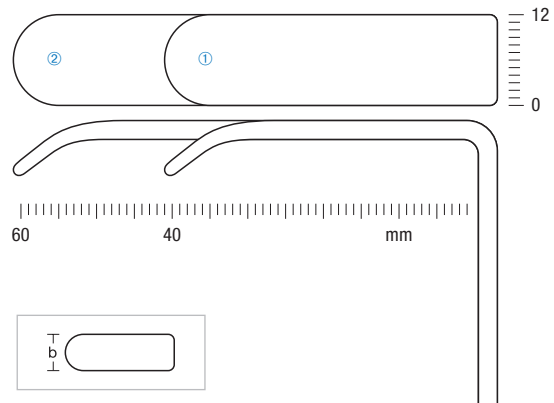

①	a = 40 mm	b = 12 mm	22 cm - 8 ³ / ₄ "	23.21.01
②	a = 60 mm	b = 12 mm	22 cm - 8 ³ / ₄ "	23.21.02

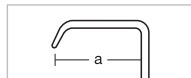
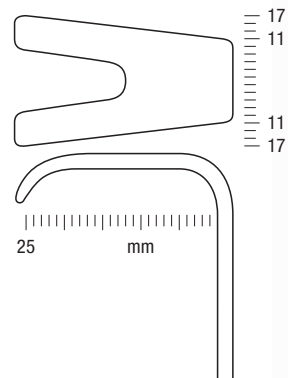

	a = 25 mm	b/c = 17/11 mm	20 cm - 8"	68.18.91
--	-----------	----------------	------------	-----------------



Wassmund



B01

Wundhaken
Retractors
Separadores
Ecarteurs
Divaricatori



Middeldorp

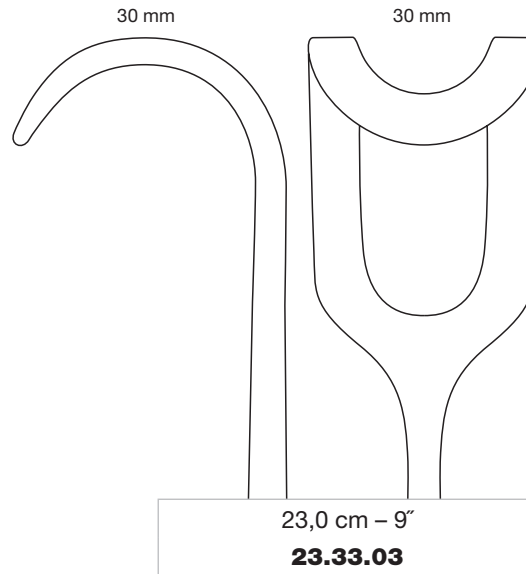
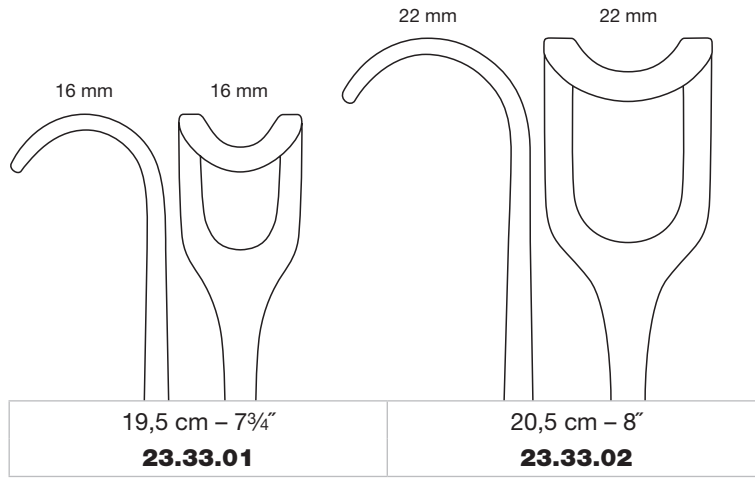



Middeldorpf

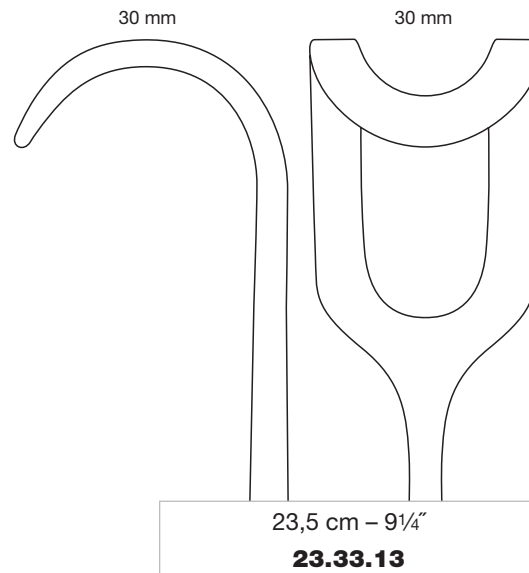
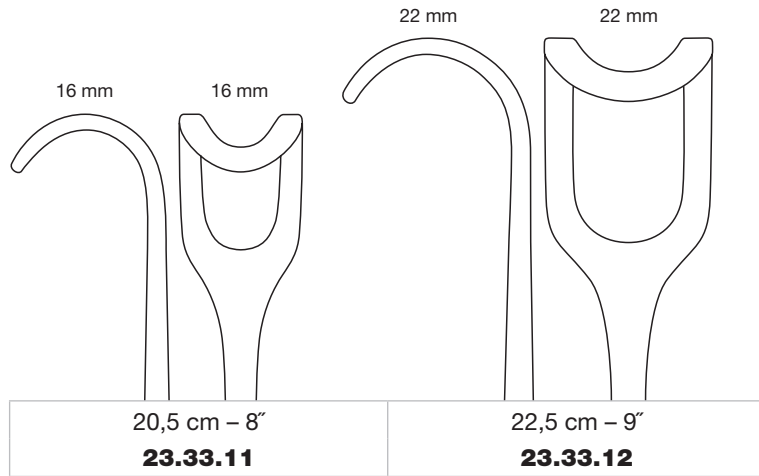



B01

Wundhaken
Retractors
Separadores
Ecarteurs
Divaricatori



Langenbeck-Kocher

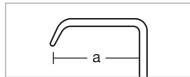
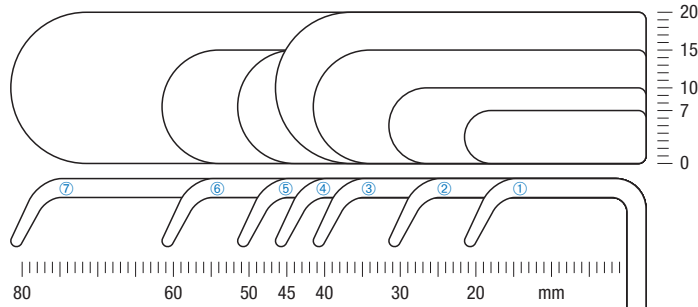

①	a = 20 mm	b = 7 mm	21 cm - 8 1/4"	23.25.01
	a = 30 mm	b = 7 mm	21 cm - 8 1/4"	23.25.02
②	a = 30 mm	b = 10 mm	21 cm - 8 1/4"	23.25.03
	a = 30 mm	b = 15 mm	21 cm - 8 1/4"	23.25.04
③	a = 30 mm	b = 20 mm	21 cm - 8 1/4"	23.25.05
	a = 40 mm	b = 10 mm	21 cm - 8 1/4"	23.25.06
④	a = 40 mm	b = 15 mm	21 cm - 8 1/4"	23.25.07
	a = 40 mm	b = 20 mm	21 cm - 8 1/4"	23.25.08
⑤	a = 45 mm	b = 20 mm	21 cm - 8 1/4"	23.25.09
	a = 50 mm	b = 10 mm	21 cm - 8 1/4"	23.25.10
⑥	a = 50 mm	b = 15 mm	21 cm - 8 1/4"	23.25.11
	a = 60 mm	b = 20 mm	21 cm - 8 1/4"	23.25.12
⑦	a = 80 mm	b = 15 mm	21 cm - 8 1/4"	23.25.13
	a = 80 mm	b = 20 mm	21 cm - 8 1/4"	23.25.14

Spina-Nasalis-Haken
Nasal spine retractors
Separadores para espina nasal
Ecarteurs d'épine nasale
Divaricatori per spina nasale

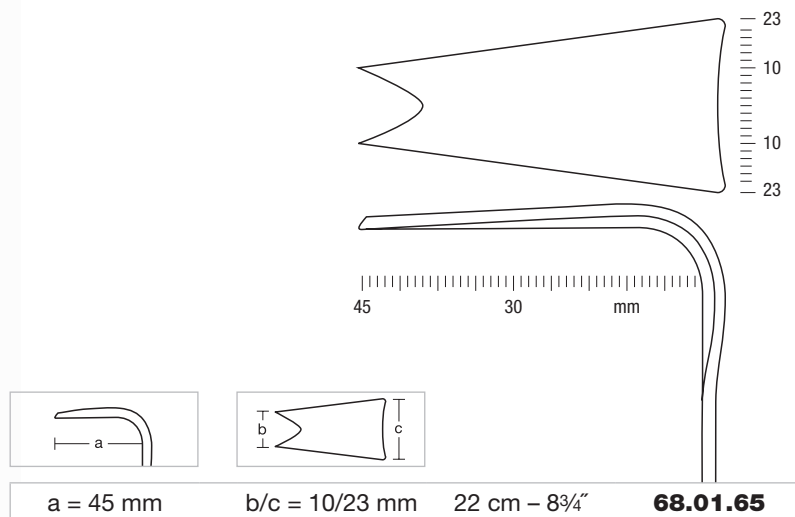
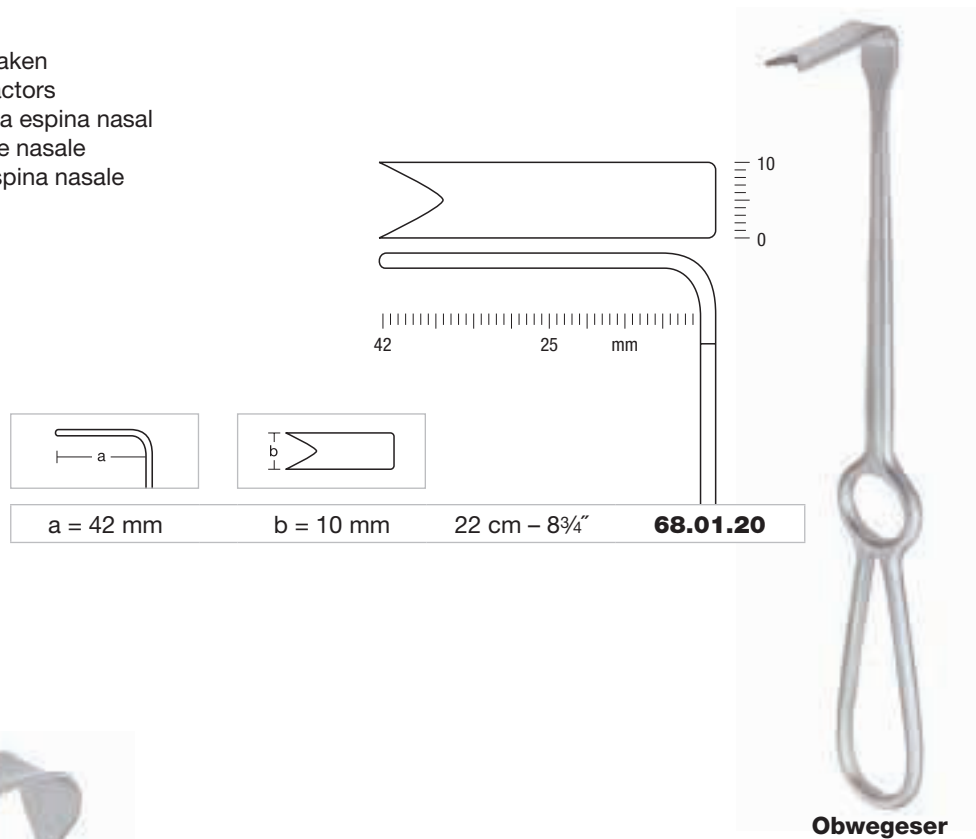

Blatt, gewölbt
Blade, curved
Hoja, abovedada
Lame, courbée
Valva, convessa



B01

**Wundhaken
Retractors
Separadores
Ecarteurs
Divaricatori**

Weichteilhaken
Soft tissue retractors
Separadores para partes blandas
Ecarteurs pour parties molles
Divaricatori per tessuti molli



Triaca

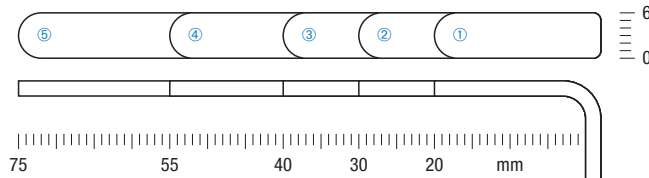

①	a = 20 mm	b = 6 mm	12 cm - 4¾"	68.06.02
②	a = 30 mm	b = 6 mm	12 cm - 4¾"	68.06.03
③	a = 40 mm	b = 6 mm	12 cm - 4¾"	68.06.04
④	a = 55 mm	b = 6 mm	12 cm - 4¾"	68.06.05
⑤	a = 75 mm	b = 6 mm	12 cm - 4¾"	68.06.07



Obwegeser

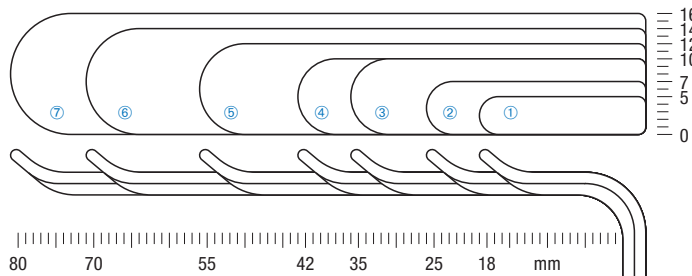

①	a = 18 mm	b = 5 mm	23 cm - 9"	68.01.31
②	a = 25 mm	b = 7 mm	23 cm - 9"	68.01.32
③	a = 35 mm	b = 10 mm	23 cm - 9"	68.01.33
④	a = 42 mm	b = 10 mm	23 cm - 9"	68.01.34
⑤	a = 55 mm	b = 12 mm	23 cm - 9"	68.01.35
⑥	a = 70 mm	b = 14 mm	23 cm - 9"	68.01.36
⑦	a = 80 mm	b = 16 mm	23 cm - 9"	68.01.37

 Blatt, gewölbt
Blade, curved
Hoja, abovedada
Lame, courbée
Valva, convessa

Weichteilhaken
Soft tissue retractors
Separadores para partes blandas
Ecarteurs pour parties molles
Divaricatori per tessuti molli



Triaca

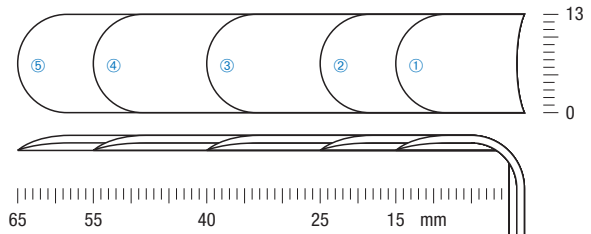

①	a = 15 mm	b = 13 mm	10 cm - 4"	68.06.11
②	a = 25 mm	b = 13 mm	10 cm - 4"	68.06.12
③	a = 40 mm	b = 13 mm	10 cm - 4"	68.06.14
④	a = 55 mm	b = 13 mm	10 cm - 4"	68.06.15
⑤	a = 65 mm	b = 13 mm	10 cm - 4"	68.06.16

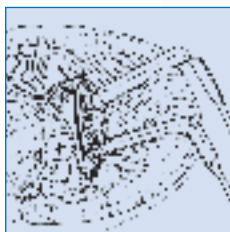

Obwegeser

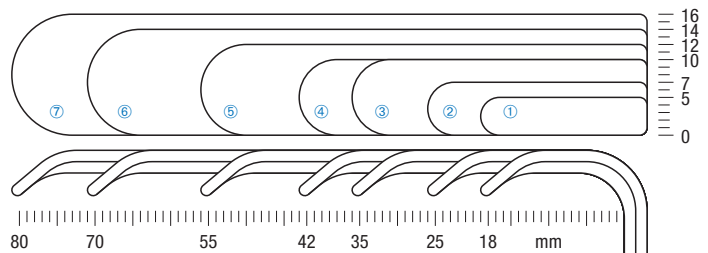

①	a = 18 mm	b = 5 mm	22,5 cm - 9"	68.01.41
②	a = 25 mm	b = 7 mm	22,5 cm - 9"	68.01.42
③	a = 35 mm	b = 10 mm	22,5 cm - 9"	68.01.43
④	a = 42 mm	b = 10 mm	22,5 cm - 9"	68.01.44
⑤	a = 55 mm	b = 12 mm	22,5 cm - 9"	68.01.45
⑥	a = 70 mm	b = 14 mm	22,5 cm - 9"	68.01.46
⑦	a = 80 mm	b = 16 mm	22,5 cm - 9"	68.01.47

Blatt, gewölbt
Blade, curved
Hoja, abovedada
Lame, courbée
Valva, convessa



B01

Wundhaken
Retractors
Separadores
Ecarteurs
Divaricatori

21
8
20
19
18
7
17
16
6
15
14
5
13
12
11
4
10
9
3
7
6
2
5
4
3
1
2
1
cm | inch



Unterkieferrand-Retraktor
Mandibular rim retractor
Separador para el borde del maxilar inferior
Ecarteur pour le bord du maxillaire inférieur
Divaricatore per il bordo della mascella inferiore



Obwegeser

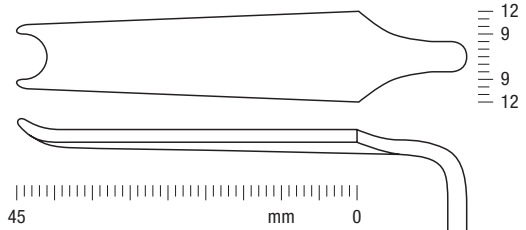

a = 45 mm b/c = 9/12 mm 17 cm - 6 3/4" **68.01.53**



Alveolar-Haken
Alveolar retractor
Separador alveolar
Ecarteur alveolaire
Uncino alveolare

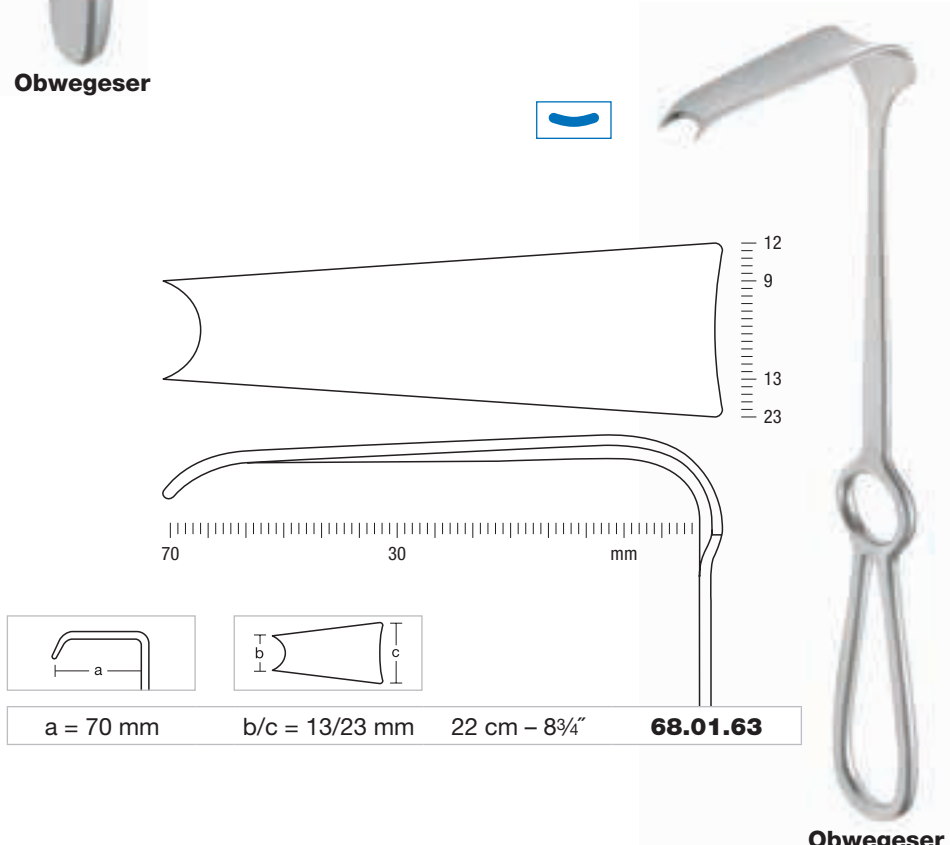

Obwegeser

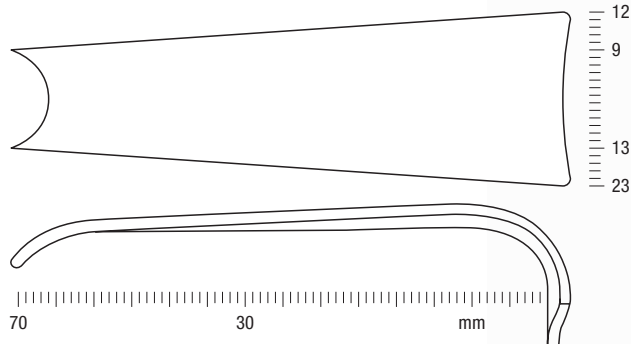

a = 70 mm b/c = 13/23 mm 22 cm - 8 3/4" **68.01.63**



Blatt, gewölbt
Blade, curved
Hoja, abovedada
Lame, courbée
Valva, convessa

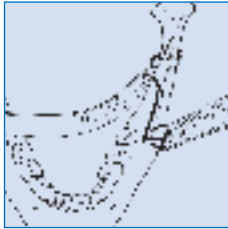

Progenie-Rinnen
Channel retractors
Separadores mandibulares
Ecarteurs mandibulaires
Divaricatori mandibolari

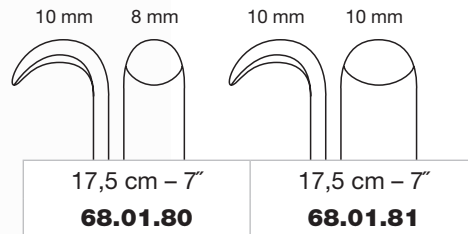

Obwegeser



Kinnhalter
Chin retractor
Gancho de mentón
Fixe-menton
Gancio per mento



Obwegeser

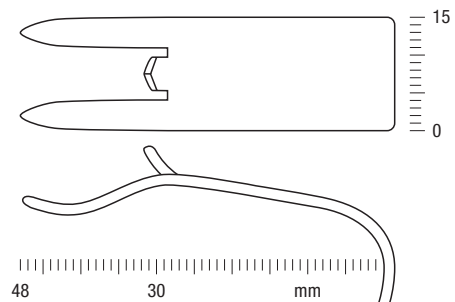



B01

Wundhaken
 Retractors
 Separadores
 Ecarteurs
 Divaricatori

21
8
20
19
18
7
17
16
6
15
5
14
13
4
12
11
3
10
9
2
8
7
3
6
5
2
4
3
1
2
1
cm | inch

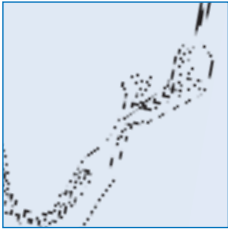

Ramus-Haken
 Ramus retractors
 Separadores para el ramo
 Ecarteurs à rameau
 Divaricatori per ramo

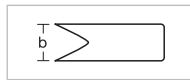
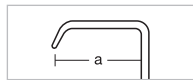
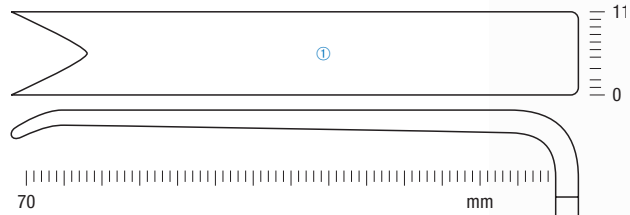

① a = 70 mm b = 11 mm 22 cm - 8 3/4" **68.01.25**

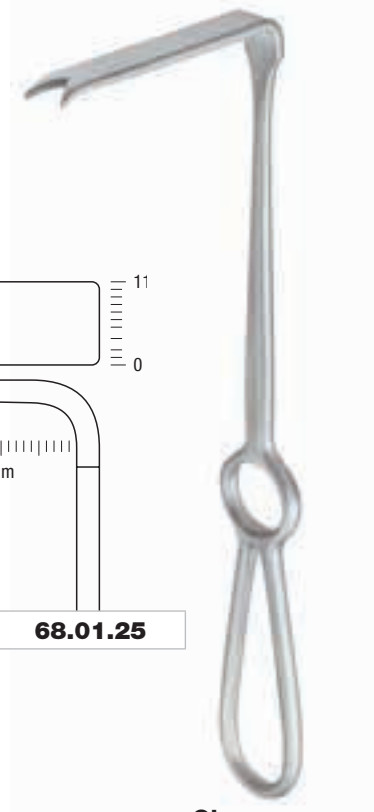

Obwegeser



Obwegeser

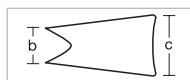
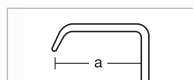
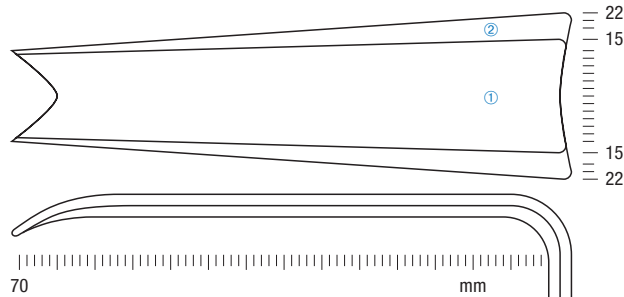

① a = 70 mm b/c = 11/15 mm 22 cm - 8 3/4" **68.01.56**
 ② a = 70 mm b/c = 12/22 mm 22 cm - 8 3/4" **68.01.57**



Blatt, gewölbt
 Blade, curved
 Hoja, abovedada
 Lame, courbée
 Valva, convessa



- ▶ Die Rinne dient zur stabilen Führung von Bohrer und Schraubendreher.
- ▶ Sie unterstützt die Verschraubung besonders in schwer zugänglichen Bereichen.
- ▶ The channel enables a secure guidance of drill and screwdriver.
- ▶ It supports screw fixation in areas with difficult access.
- ▶ La ranura sirve como guía estable para el perforador y atornillador.
- ▶ En consecuencia apoya el atornillamiento sobre todo en regiones menos accesibles.
- ▶ Le conduit sert au guidage stable de forets et de tournevis.
- ▶ Il supporte le vissage dans des régions dont l'accès est difficile.
- ▶ La scanalatura serve per una guida stabile del perforatore e cacciavite.
- ▶ La quale sostiene l'avvitamento in parti difficilmente accessibili.

mit Bohrhilfe
with drilling channel
con guía de perforación
avec guide pour perçage
con guida per la perforazione

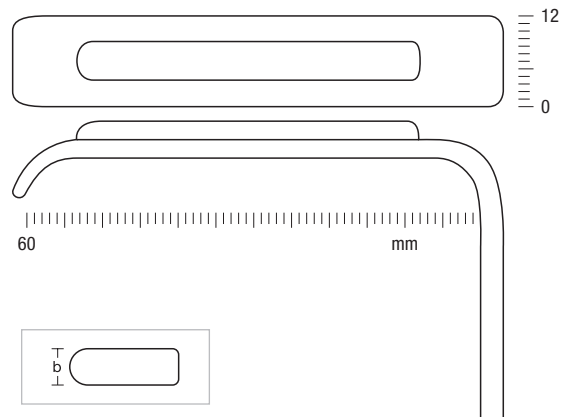
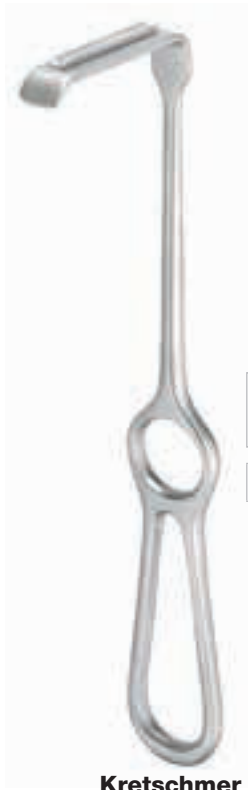

a = 60 mm	b = 12 mm	21 cm – 8¼"	68.05.30
-----------	-----------	-------------	-----------------



B01

Wundhaken, doppelendig
Retractors, double-ended
Separadores, dobles
Ecarteurs, doubles
Divaricatori, doppi



Collin

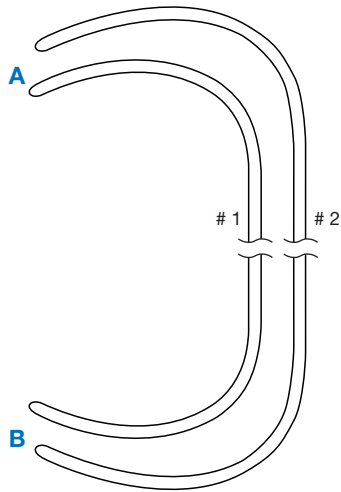

	# 1	# 2
A	15 x 28 mm	17 x 32 mm
B	15 x 28 mm	17 x 32 mm
16,5 cm – 6½"		
22.12.15		



Parker

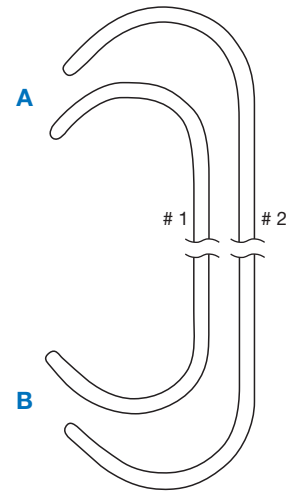

	# 1	# 2
A	16 x 18 mm	16 x 22 mm
B	16 x 18 mm	16 x 22 mm
13 cm – 5⅛"		
22.14.13		



Parker

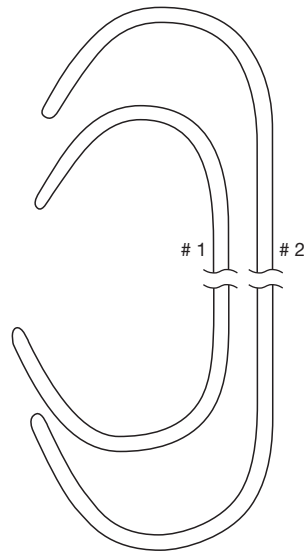

	# 1	# 2
A	26 x 24 mm	26 x 27 mm
B	26 x 25 mm	26 x 28 mm
18 cm – 7⅛"		
22.14.18		



**Parker-Langenbeck
(US-Army)**

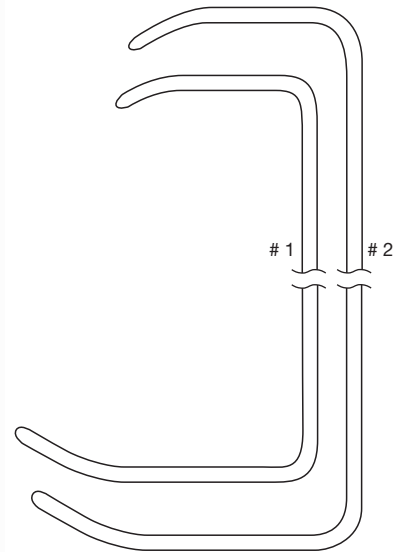

	# 1	# 2
A	15 x 23 mm	15 x 28 mm
B	15 x 37 mm	15 x 40 mm
21 cm – 8¼"		
22.18.21		

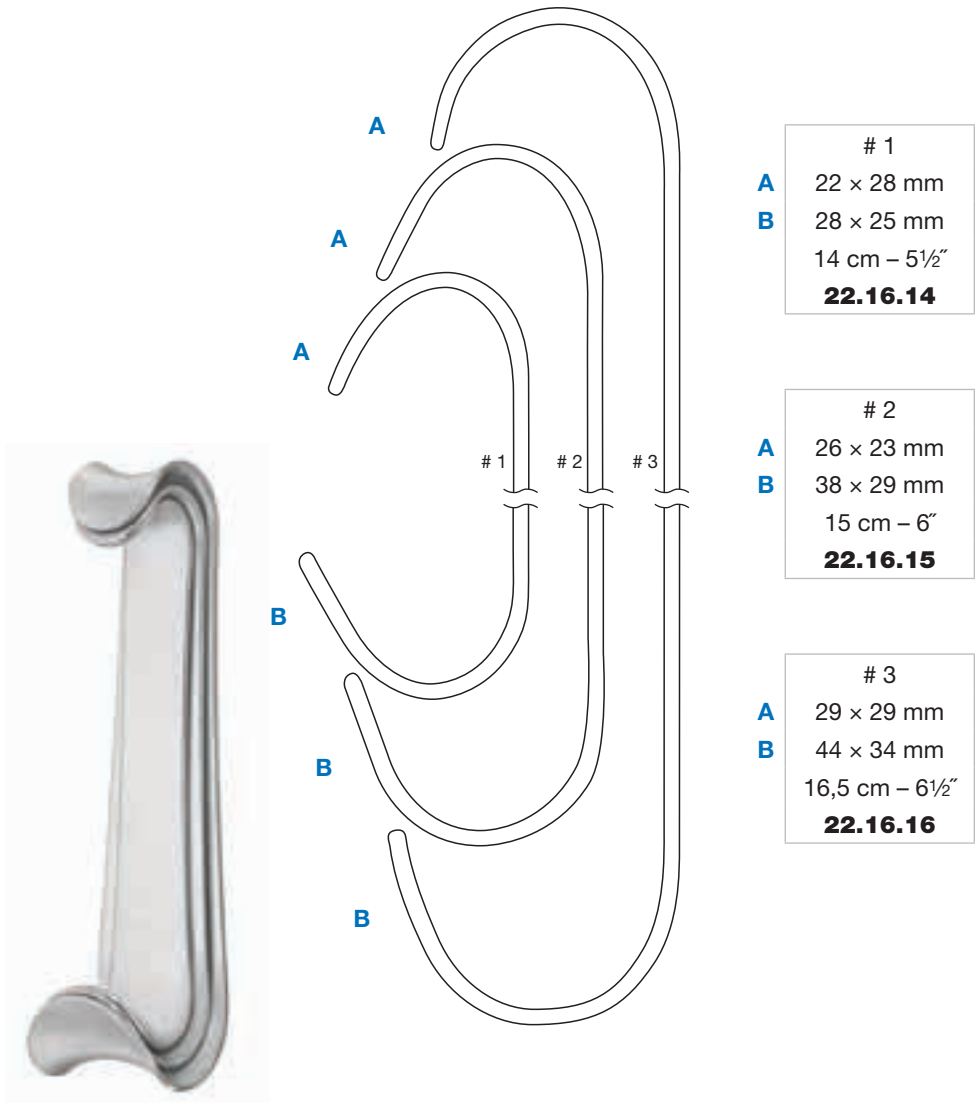

1
A 22 × 28 mm
B 28 × 25 mm
 14 cm – 5½"
22.16.14

2
A 26 × 23 mm
B 38 × 29 mm
 15 cm – 6"
22.16.15

3
A 29 × 29 mm
B 44 × 34 mm
 16,5 cm – 6½"
22.16.16

Roux		22.16.00	
Satz bestehend aus: Set consisting of: Juego compuesto por: Jeu composé de: Set composto da:	22.16.14	Retractor, double-ended, # 1	1×
	22.16.15	Retractor, double-ended, # 2	1×
	22.16.16	Retractor, double-ended, # 3	1×



B01

Mukosa-Spanner und Ramus-Klemmen
Mucosa Stretcher and Ramus Clamps
Tensor de mucosa y clamps para el ramo
Tendeur de muqueuse et clamps à rameau
Tenditore di mucosa e pinze per ramo



Mukosa-Spanner
 Mucosa stretcher
 Tensor de mucosa
 Tendeur de muqueuse
 Tenditore di mucosa

mit Schleimhauthaken
 with mucosa retractor
 con separador de mucosa
 avec crochet pour muqueuse
 con divaricatore per mucosa

10 cm – 4"
68.25.20



Steinhäuser

68.25.21

Schleimhauthaken (allein)
 Mucosa retractor (only)
 Separador de mucosa (solo)
 Crochet pour muqueuse (seul)
 Divaricatore per mucosa (solo)

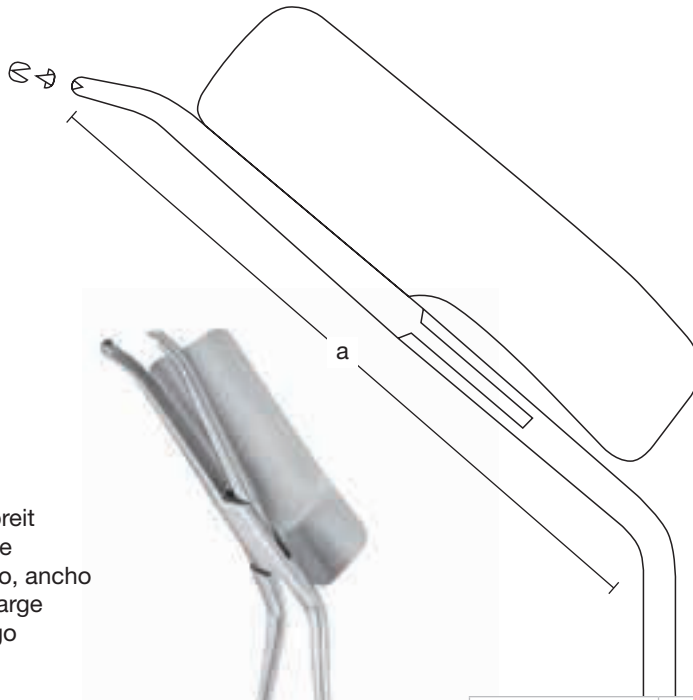

Ramus-Klemmen, breit
 Ramus clamps, wide
 Clamps para el ramo, ancho
 Clamps à rameau, large
 Pinze per ramo, largo

a = 100 mm
 18 cm – 7 1/8"
68.01.72

Blatt rechts
 Blade right
 Hoja derecha
 Lame droite
 Valva a destra



a = 100 mm
 18 cm – 7 1/8"
68.01.73

Blatt links
 Blade left
 Hoja izquierda
 Lame gauche
 Valva a sinistra



Obwegeser

Extraorale und intraorale Retraktoren
Extra and Intra Oral Retractors
Separadores extra orales y intra orales
Ecarteurs extra-oraux et intra-oraux
Divaricatori extraorali e intraorali

B01

Extraorale Retraktoren
 Extra oral retractors
 Separadores extra orales
 Ecarteurs extra-oraux
 Divaricatori extraorali

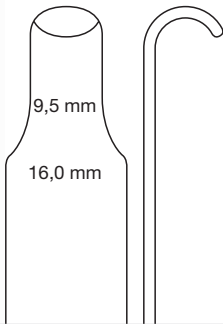

22 cm – 8¾"

68.02.69

25,5 cm – 10"

68.02.70



Intraorale Retraktoren
 Intra oral retractors
 Separadores intra orales
 Ecarteurs intra-oraux
 Divaricatori intraorali

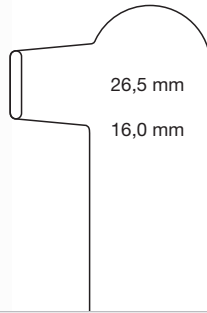
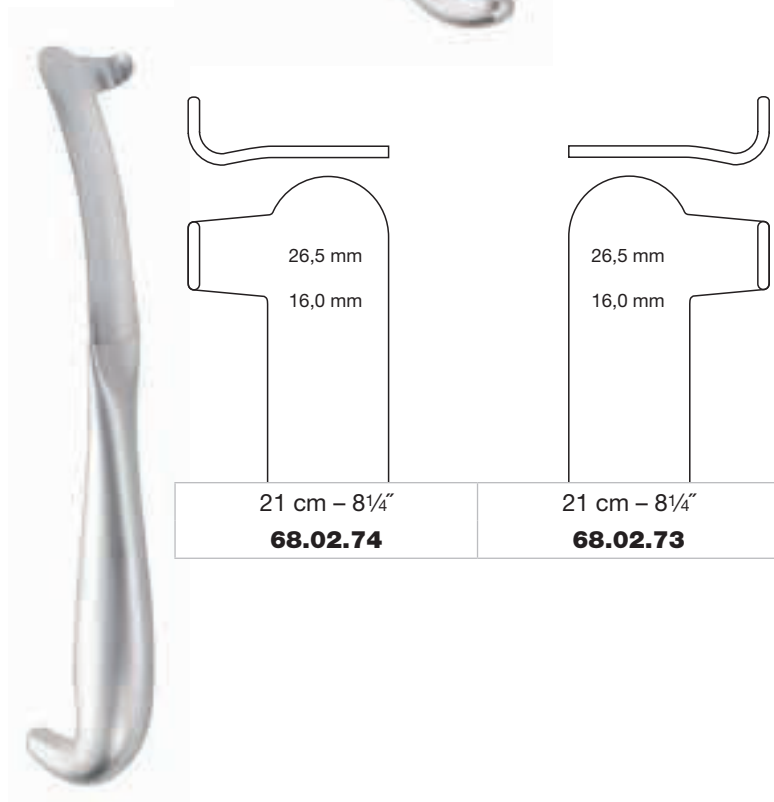

21 cm – 8¼"

68.02.74

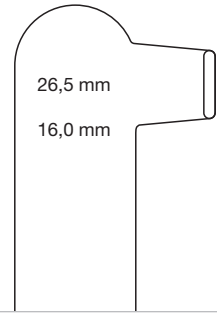

21 cm – 8¼"

68.02.73



mit Kaltlichtbeleuchtung
 with fibre optic illumination
 con iluminación de luz fría
 avec illumination à lumière froide
 con illuminazione a luce fredda



B01

Intraorale Retraktoren
Intra Oral Retractors
Separadores intra orales
Ecarteurs intra-oraux
Divaricatori intraorali

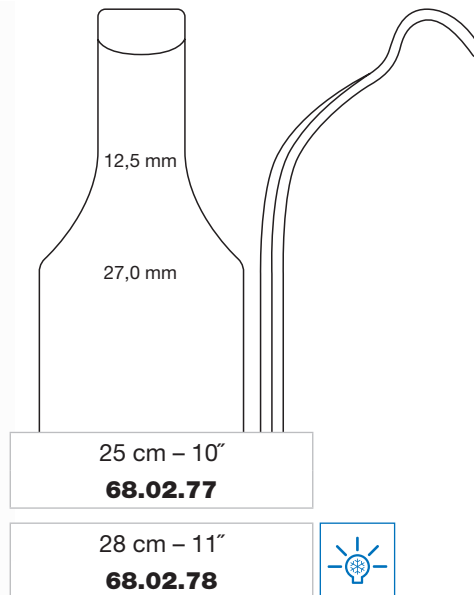
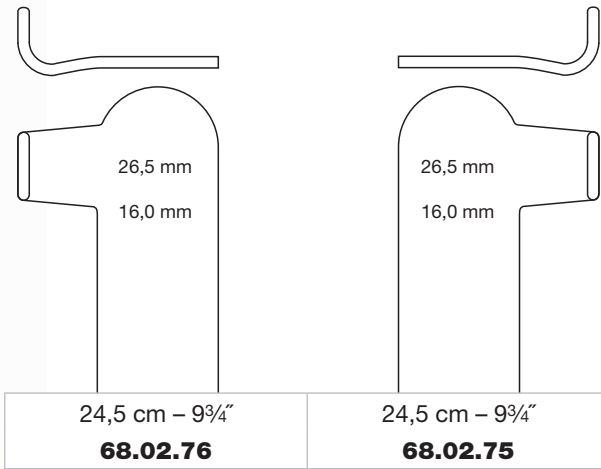
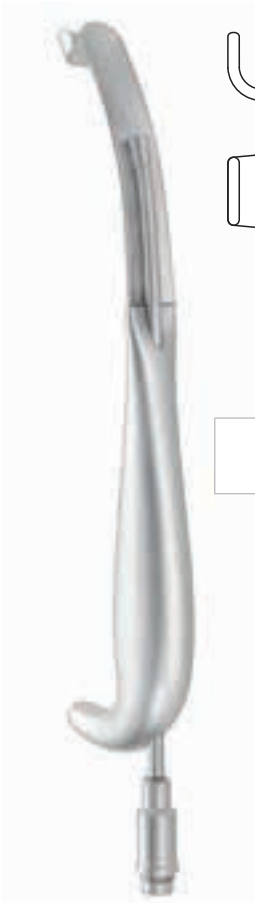

mit Kaltlichtbeleuchtung
 with fibre optic illumination
 con illuminación de luz fría
 avec illumination à lumière froide
 con illuminazione a luce fredda

Lidhalter und Orbitahaken
Lid Retractors and Orbital Hooks
Separadores para párpados y separadores orbitales
Releveurs à paupières et crochets orbitaux
Elevatori per palpebre e retrattore orbitale

B02

Lidhalter
 Lid retractors
 Separadores para párpados
 Releveurs à paupières
 Elevatori per palpebre



Desmarres

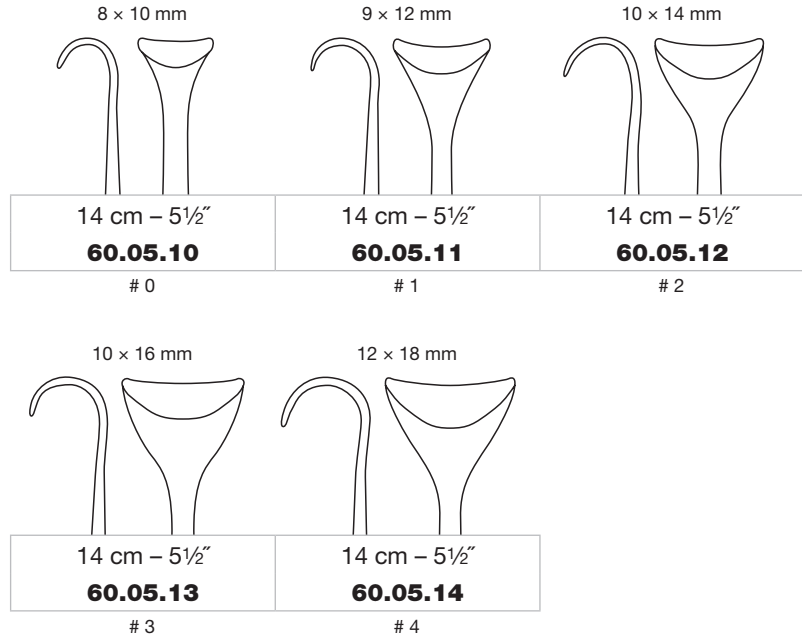

Orbitahaken
 Orbital hooks
 Separadores orbitales
 Crochets orbitaux
 Retrattore orbitale

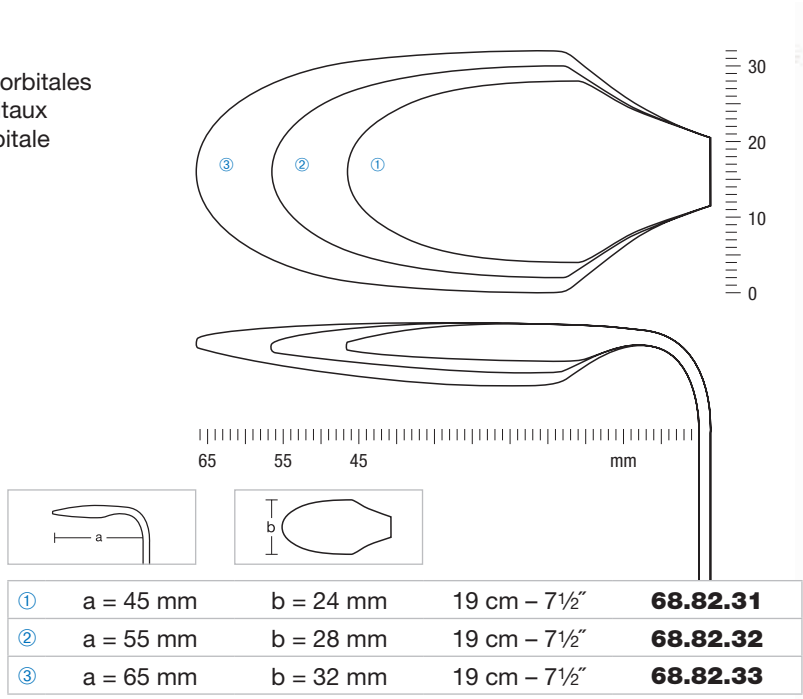

Kluba



B03

Wundspreizer und Lidplatte
Self-retaining Retractors and Lid Plate
Separadores autoestáticos y placa para párpados
Ecarteurs autostatiques et plaque à paupières
Divaricatori autostatici e piastra per palpebre

Wundspreizer
 Self-retaining retractors
 Separadores autoestáticos
 Ecarteurs autostatiques
 Divaricatori autostatici

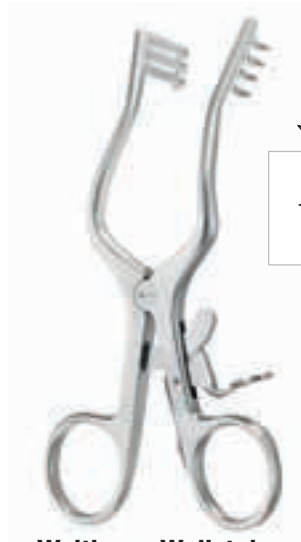
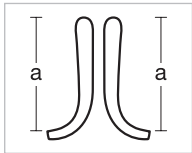

Weitlaner-Wullstein

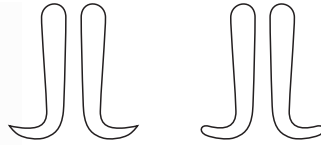

a = 18 mm
 13 cm – 5 1/8"

24.26.13



a = 18 mm
 16,5 cm – 6 1/2"

24.26.14



Lidplatte
 Lid plate
 Placa para párpados
 Plaque à paupières
 Piastra per la palpebra



1:1

Jaeger

a = 20 mm 11 cm – 4 3/8" **60.05.95** b = 23 mm



scharf
 sharp
 agudo
 pointu
 acuto



stumpf
 blunt
 roma
 mousse
 smussa

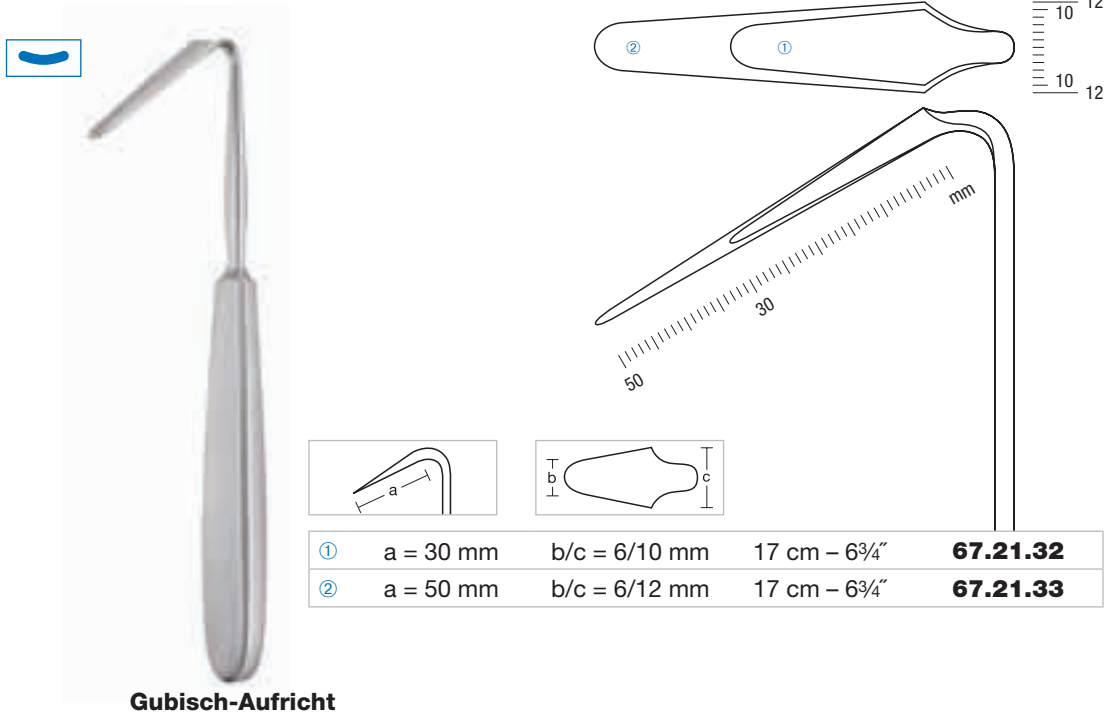

Gubisch-Aufricht

①	a = 30 mm	b/c = 6/10 mm	17 cm - 6¾"	67.21.32
②	a = 50 mm	b/c = 6/12 mm	17 cm - 6¾"	67.21.33

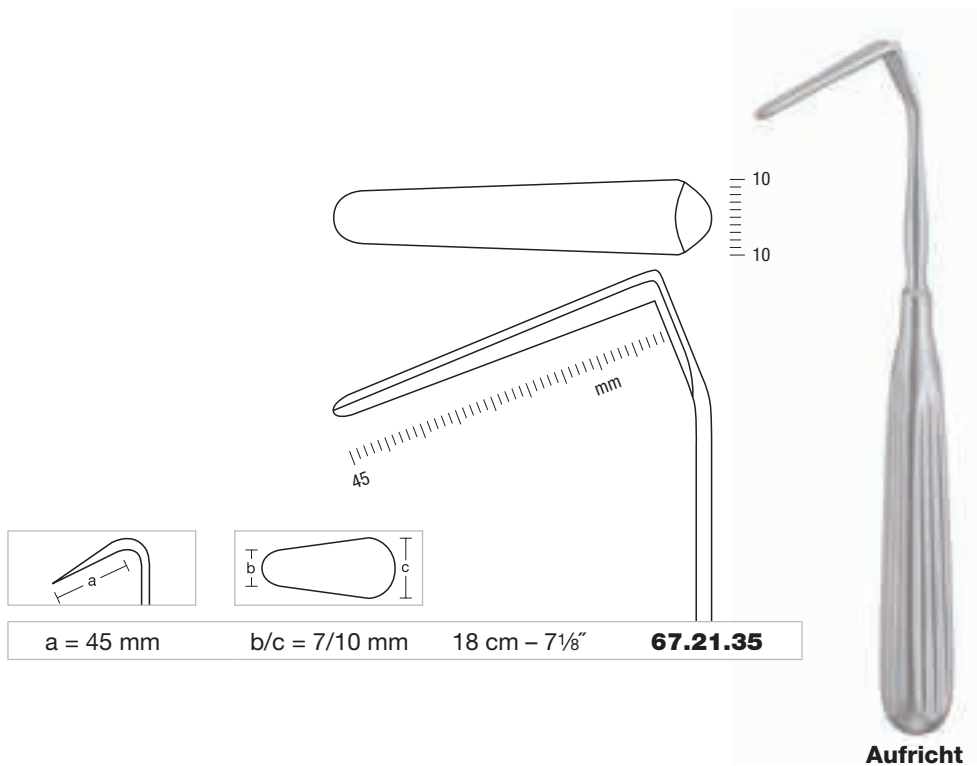

Aufricht

a = 45 mm	b/c = 7/10 mm	18 cm - 7⅛"	67.21.35
-----------	---------------	-------------	-----------------

 Blatt, gewölbt
 Blade, curved
 Hoja, abovedada
 Lame, courbée
 Valva, convessa



B04

Lippen- und Wangenhalter
Lip and Cheek Retractors
Separadores de labios y mejillas
Ecarteurs de lèvres et de joues
Divaricatori per labbra e guance



Vestibulumhaken
 Vestibule retractors
 Separadores vestibulares
 Ecarteurs vestibulaires
 Divaricatori vestibulari



26 cm – 10¼"
68.01.98

für Unterkiefer
 for lower jaw
 para mandíbula inferior
 pour mâchoire inférieure
 per mascella inferiore



21 cm – 8¼"
68.01.97

für Oberkiefer
 for upper jaw
 para mandíbula superior
 pour mâchoire supérieure
 per mascella superiore

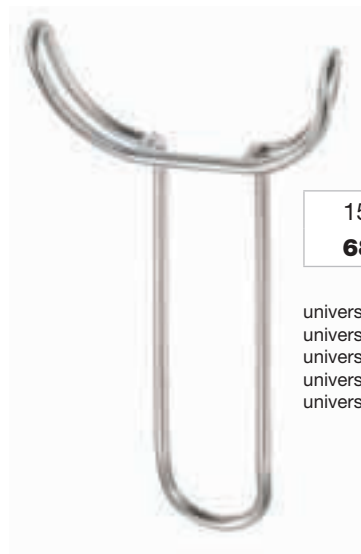

15 cm – 6"
68.01.99

universal
 universal
 universal
 universel
 universale

①	a = 40 mm	b = 12 mm	21 cm - 8 1/4"	68.18.92
②	a = 55 mm	b = 14 mm	21 cm - 8 1/4"	68.18.93

Dockhorn

15,5 cm - 6 1/8"
72.02.10

mit Zungendrucker
 with tongue depressor
 con bajalengua
 avec abaisse-langue
 con abbassalingua

Univ. Minnesota Cawood

14,5 cm - 5 3/4"
72.02.15

mit Zungendrucker
 with tongue depressor
 con bajalengua
 avec abaisse-langue
 con abbassalingua

Sternberg



B05

Zungenspatel Tongue Spatulas Espátulas bucales Spatules à langue Spatole per lingua



Holz
Wood
Madera
Bois
Legno



P ₁₀₀	a = 20 mm	16 cm – 6¼"	72.00.01	b = 20 mm
-------------------------	-----------	-------------	-----------------	-----------



a = 18 mm	14,5 cm – 5¾"	72.00.10	b = 18 mm
-----------	---------------	-----------------	-----------



a = 20 mm	14 cm – 5½"	72.00.15	b = 23 mm
-----------	-------------	-----------------	-----------



Buchwald

a = 18 mm	18 cm – 7⅛"	72.00.18	b = 23 mm
-----------	-------------	-----------------	-----------



Brünings

a = 14 mm	19 cm – 7½"	72.00.50	b = 18 mm
-----------	-------------	-----------------	-----------



Doyen

a = 22 mm	12 cm – 4¾"	72.00.27	b = 29 mm
a = 30 mm	16 cm – 6¼"	72.00.28	b = 33 mm



Verpackungseinheit "X" Stück
Packing unit "X" pieces
Paquete de "X" unidades
Emballage de "X" pièces
Confezione da "X" pezzi

Zungenzangen und Mundkeile
Tongue Seizing Forceps and Mouth Gags
Pinzas tiralengua y abre bocas
Pinces tire-langue et baillons
Pinze tiralingua e apribocca

B05



Collin

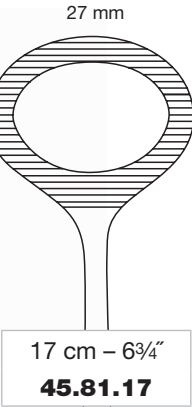

Young

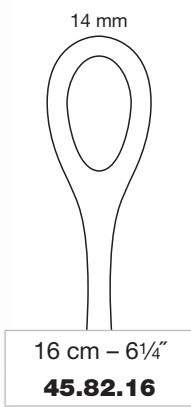

45.82.17

Ersatz-Gummieinlagen (Paar)
 Spare rubber inserts (pair)
 Gomas de repuesto (par)
 Mors en caoutchouc de rechange (paire)
 Gommini di ricambio (paio)

Mundkeile
 Mouth gags
 Abre bocas
 Baillons
 Apribocca



McKesson

für Kleinkinder
 for infants
 para niños pequeños
 pour petits enfants
 per infanti

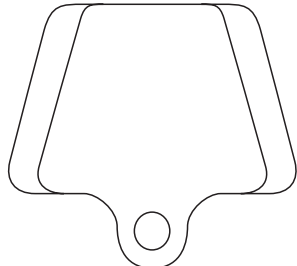

P₂

72.10.01

für Kinder
 for children
 para niños
 pour enfants
 per bambini

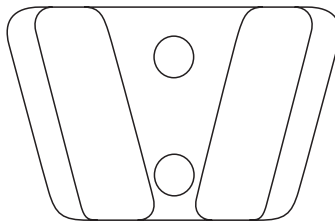

P₂

72.10.02

für Erwachsene
 for adults
 para adultos
 pour adultes
 per adulti

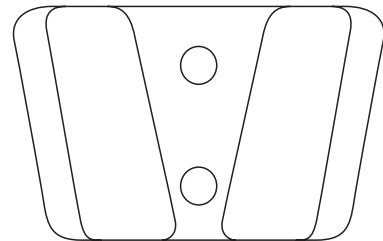

P₂

72.10.03



Verpackungseinheit "X" Stück
 Packing unit "X" pieces
 Paquete de "X" unidades
 Emballage de "X" pièces
 Confezione da "X" pezzi



B05

Zungendrucker
Tongue Depressors
Bajalenguas
Abaisse-langues
Abbassalingua

21
8
20
19
18
17
16
15
14
13
12
11
4
10
9
8
3
7
6
2
5
4
3
1
2
1
cm | inch

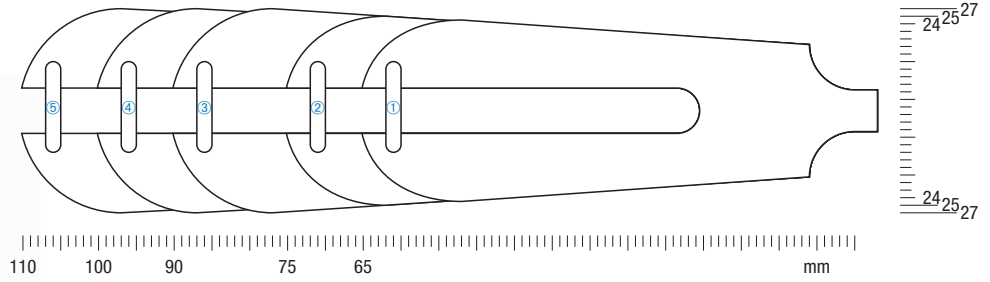

① # 1	a = 65 mm	b = 24 mm	45.51.31
② # 2	a = 75 mm	b = 25 mm	45.51.32
③ # 3	a = 90 mm	b = 27 mm	45.51.33
④ # 4	a = 100 mm	b = 27 mm	45.51.34
⑤ # 5	a = 110 mm	b = 27 mm	45.51.35

45
40
37
32
28
28
32
37
40
45

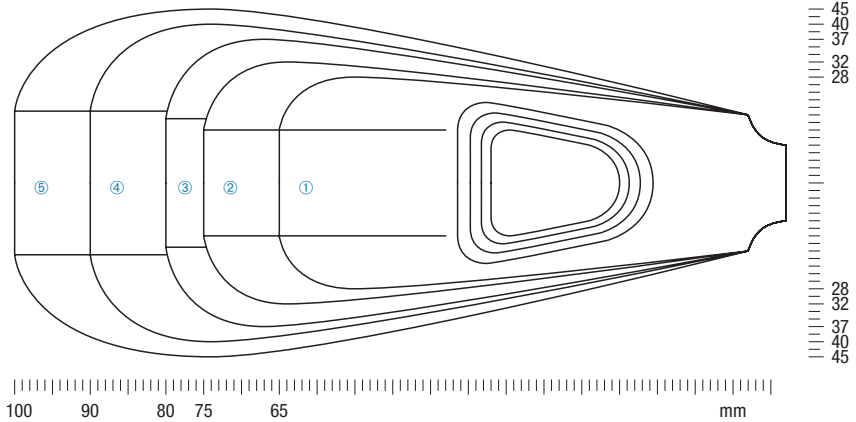

① # 1	a = 65 mm	b = 28 mm	45.57.11
② # 2	a = 75 mm	b = 32 mm	45.57.12
③ # 3	a = 80 mm	b = 37 mm	45.57.13
④ # 4	a = 90 mm	b = 40 mm	45.57.14
⑤ # 5	a = 100 mm	b = 45 mm	45.57.15

Kilner-Doughty

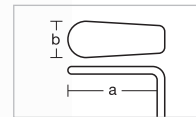
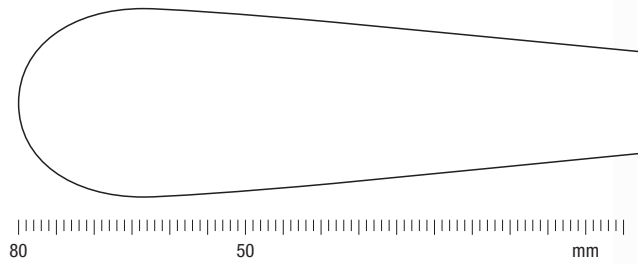

a = 80 mm
b = 25 mm
72.01.15

Tobold

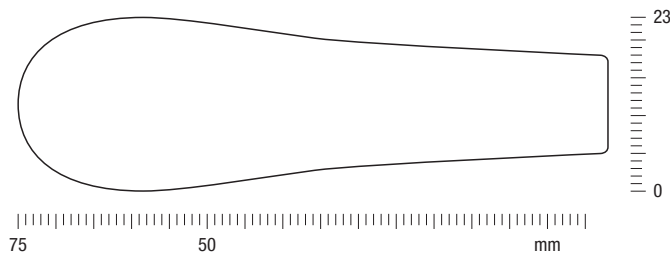

Hartmann

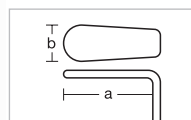

a = 75 mm
b = 23 mm
72.01.25

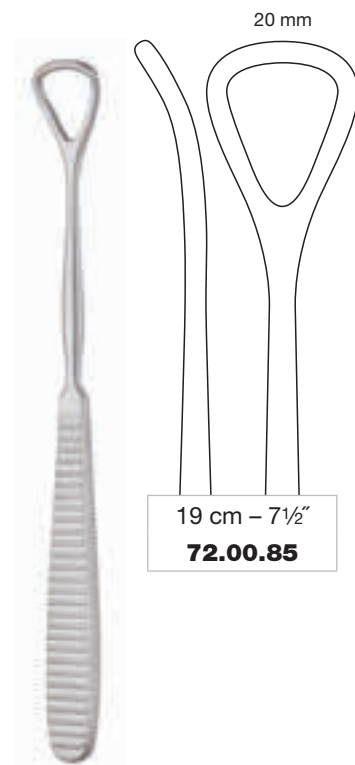

Moritz-Schmidt



B05

Zungendrucker
Tongue Depressors
Bajalenguas
Abaisse-langues
Abbassalingua

21
8
20
19
18
7
17
16
6
15
14
5
13
12
4
11
10
3
9
8
3
7
6
2
5
4
1
3
2
1
cm | inch



Wieder

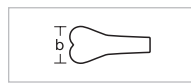
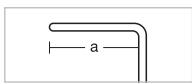
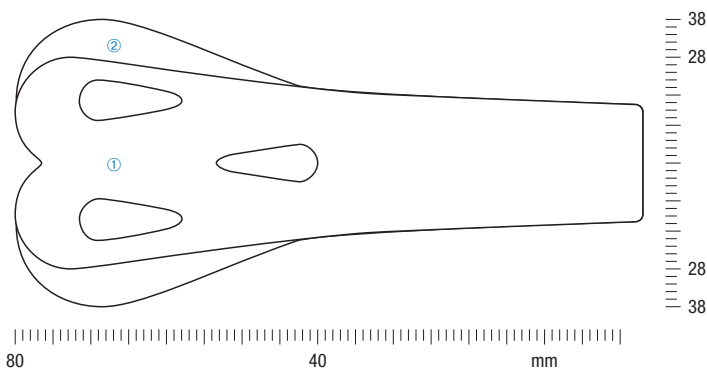

①	a = 80 mm	b = 28 mm	72.01.40
②	a = 80 mm	b = 38 mm	72.01.41



Dingman

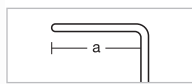
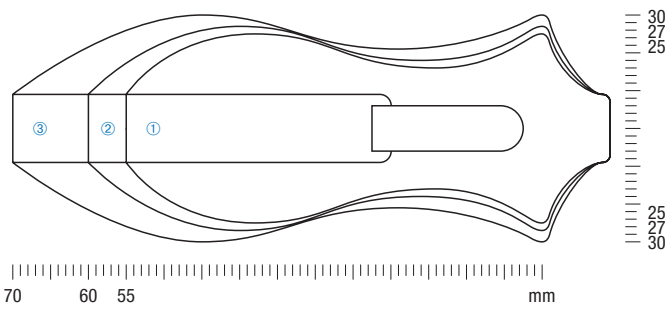

① # 1	a = 55 mm	b = 25 mm	72.08.11
② # 2	a = 60 mm	b = 27 mm	72.08.12
③ # 3	a = 70 mm	b = 30 mm	72.08.13

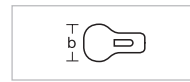
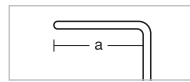
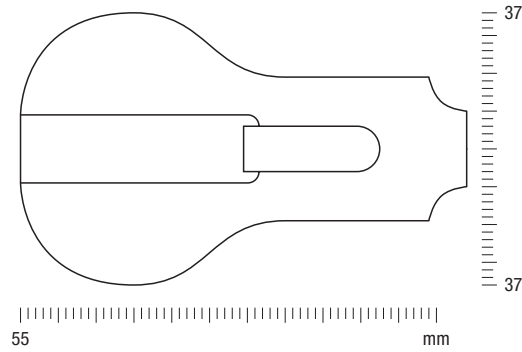

a = 55 mm

b = 37 mm

72.08.14

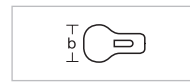
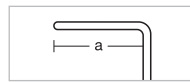
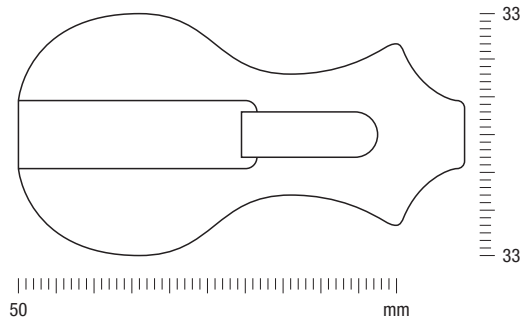

a = 50 mm

b = 33 mm

72.08.15

Zungendrücker (72.08.14-15) verwendbar mit Mundsperrer:
Tongue depressors (72.08.14-15) for use with mouth gag:
Bajalenguas (72.08.14-15) aplicable con el abrebooca:
Abaisse-langues (72.08.14-15) à utiliser avec l'ouvre-bouche:
Abbassalingua (72.08.14-15) utilizzabile con l'apribocca:



Köln
45.52.31

B05

Mundsperrer
Mouth Gag
Abreboca
Ouvre-bouche
Apribocca

- ▶ Zahnhaken, gebogen
- ▶ Geringe Traumatisierung der Mundwinkel
- ▶ Verbesserte Sicht

- ▶ Tooth hooks, curved
- ▶ Less traumatization of corners of the mouth
- ▶ Improved visibility

- ▶ Ganchos dentales, curvados
- ▶ Poco traumatismo de la comisura bucal
- ▶ Visión mejorada

- ▶ Crochets dentales, courbés
- ▶ Traumatisation des coins de bouche réduite
- ▶ Visibilité améliorée

- ▶ Uncini dentali, curvati
- ▶ Traumatizzazione ridotta nei angoli della bocca
- ▶ Vista migliore

Köln
45.52.30

Satz bestehend aus: Set consisting of: Juego compuesto por: Jeu composé de: Set composto da:	45.52.31	Rahmen mit 2 Zahnhaken (ohne Zungendrücker) Frame with 2 tooth hooks (without tongue depressors) Bastidor con 2 ganchos dentales (sin bajalenguas) Cadre avec 2 crochets dentaires (sans abaisse-langues) Telaio con 2 uncini dentali (senza abbassalingua)	1x
	45.57.11 72.08.11 72.08.12 72.08.13	Zungendrücker Tongue depressors Bajalenguas Abaisse-langues Abbassalingua	1x # 1 1x # 1 1x # 2 1x # 3



90-93



Zungendrücker (siehe Seite 90-93)
 Tongue depressors (see page 90-93)
 Bajalenguas (véase página 90-93)
 Abaisse-langues (voir page 90-93)
 Abbassalingua (vedi pagina 90-93)

451.03.01

Weitere Informationen finden Sie in unserem Sonderprospekt
 For further information please see our special brochure
 Informaciones adicionales se encuentran en nuestro folleto especial
 Vous trouverez de plus amples informations dans notre prospectus spécial
 Ulteriori informazioni si possono trovare sul nostro depliant speciale



siehe Seite
 see page
 véase página
 voir page
 vedi pagina

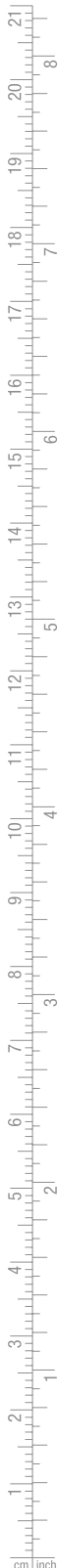



Dingman		72.08.00	
Satz bestehend aus: Set consisting of: Juego compuesto por: Jeu composé de: Set composto da:	72.08.20	Rahmen, allein (ohne Zungendrucker) Frame, only (without tongue depressors) Bastidor, solo (sin bajalenguas) Cadre, seul (sans abaisse-langues) Telaio, solo (senza abbassalingua)	1x
		Zahnhaken Tooth hooks Ganchos dentales Crochets dentaires Ganci dentali	2x
		Wangenhaken Cheek retractors Separadores de mejillas Ecarteurs pour joues Divaricatori per guancia	2x
	72.08.11	Zungendrucker	1x # 1
	72.08.12	Bajalenguas	1x # 2
72.08.13	Abaisse-langues	1x # 3	
	72.08.13	Abbassalingua	

 90-93		Zungendrucker (siehe Seite 90-93) Tongue depressors (see page 90-93) Bajalenguas (véase página 90-93) Abaisse-langues (voir page 90-93) Abbassalingua (vedi pagina 90-93)
-----------	--	---



B05

Mundsperrer und Zungenspatel
Mouth Gags and Tongue Spatulas
Abrebocas y espátulas bucales
Ouvre-bouches et spatules à langue
Apribocca e spatole per lingua



Mundsperrer
 Mouth gags
 Abrebocas
 Ouvre-bouches
 Apribocca



907.20.20

Silikonschutz, allein (Paar)
 Silicone guard, only (pair)
 Goma de silicona, sola (par)
 Protection en silicone, seule (paire)
 Protezione di silicone, sola (paio)

Auflagen, beweglich
 Supports, movable
 Soportes, móviles
 Support, mobiles
 Supporti, mobili



Denhart

12,5 cm – 5"
72.05.61



Denhart-Hoefert

12,5 cm – 5"
72.05.63

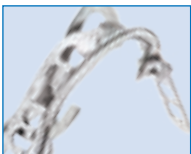

Zungenspatel
 Tongue spatulas
 Espátulas bucales
 Spatules à langue
 Spatole per lingua

Zungenspatel verwendbar nur mit Mundsperrer:
 Tongue spatulas only for use with mouth gag:
 Espátulas bucales sólo aplicable con el abrebooca:
 Spatules à langue seulement à utiliser avec l'ouvre-bouche:
 Spatole per lingua utilizzabile solo con l'apribocca:

Denhart-Hoefert
72.05.63



Hanna

20 cm – 8"
72.00.52



Claudinha

21 cm – 8¼"
72.00.56

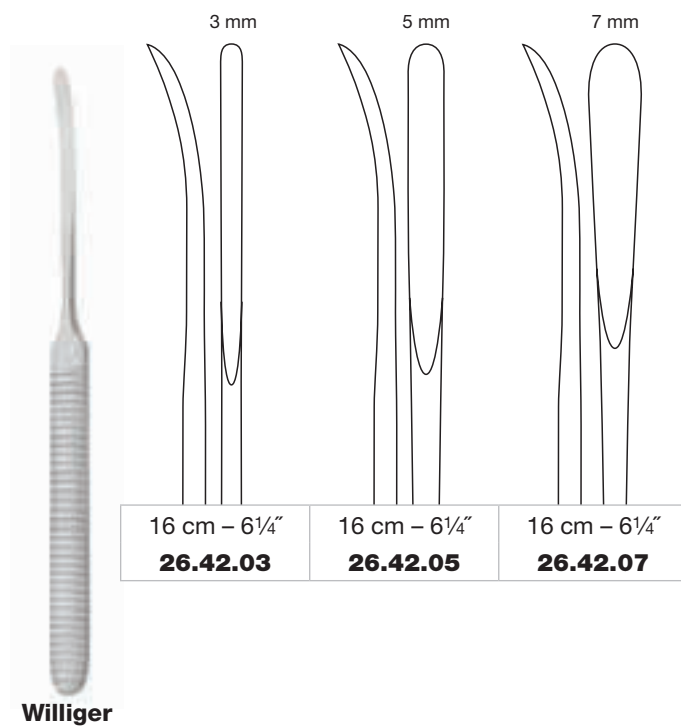
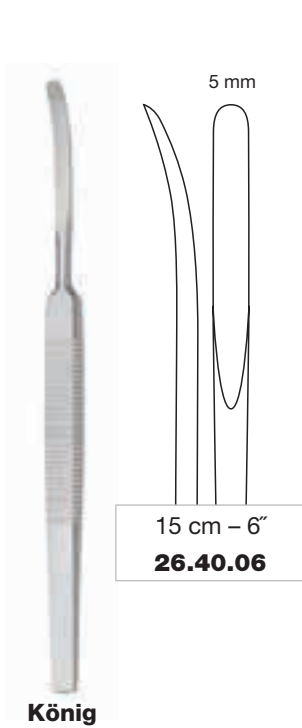
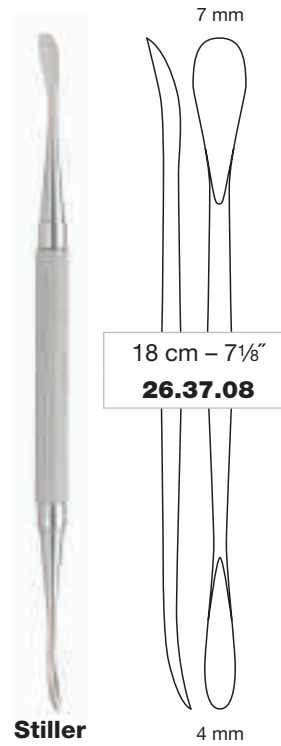
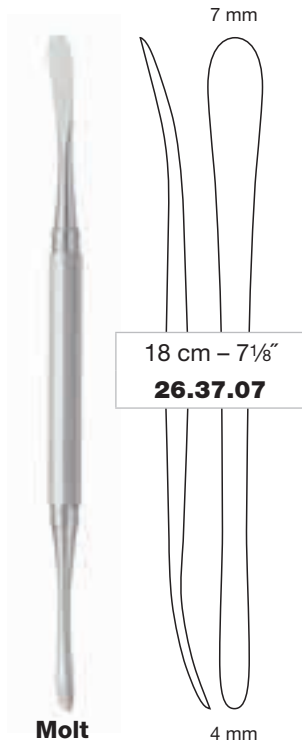



B06

Raspatorien
Raspatories
Legras
Rugines
Periostotomi

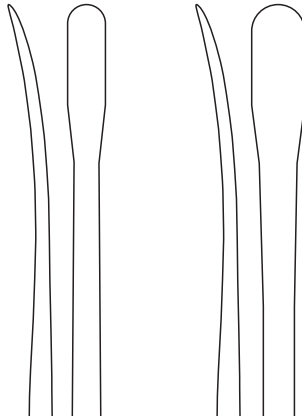

5 mm 7 mm

16 cm – 6¼"	16 cm – 6¼"
26.42.06	26.42.08

Williger

4 mm 5 mm

16 cm – 6¼"	16 cm – 6¼"
26.42.14	26.42.15

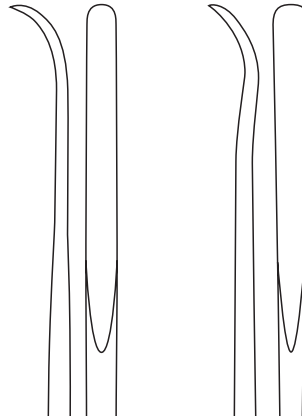

Kahre-Williger

6 mm 8 mm

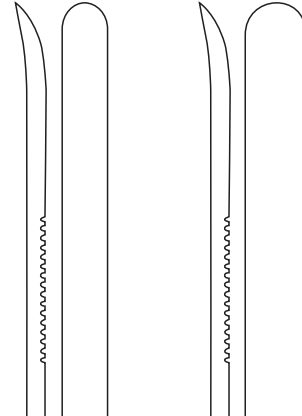
17 cm – 6¾"	17 cm – 6¾"
26.42.56	26.42.58

9 mm





17 cm – 6¾"
26.48.01

Adson

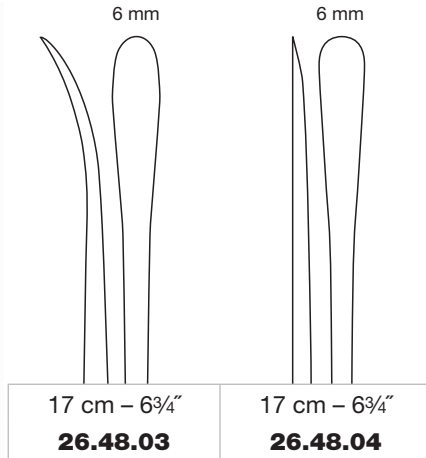

Adson



Hourigan

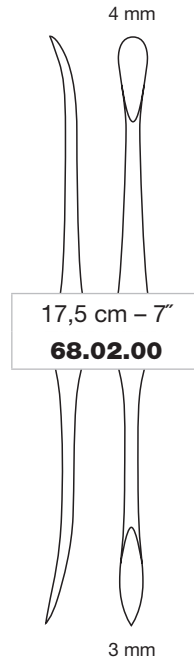

Obwegeser





B06

Raspatorien
Raspatories
Legras
Rugines
Periostotomi

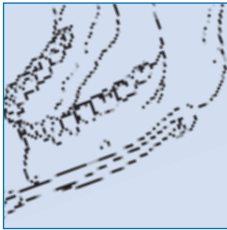

Obwegeser

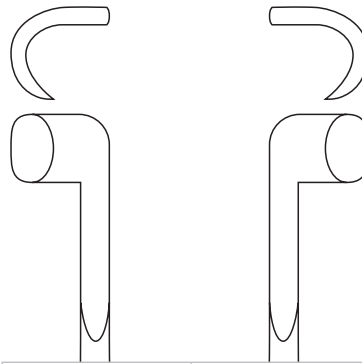

18 cm – 7 1/8"	18 cm – 7 1/8"
68.02.06	68.02.07

Linke Seite
Left side
Lado izquierdo
Côté gauche
Lato sinistro

Rechte Seite
Right side
Lado derecho
Côté droite
Lato destro



Obwegeser

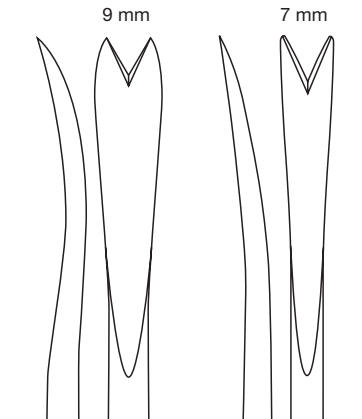

17,5 cm – 7"	17,5 cm – 7"
68.02.08	68.02.09



Obwegeser

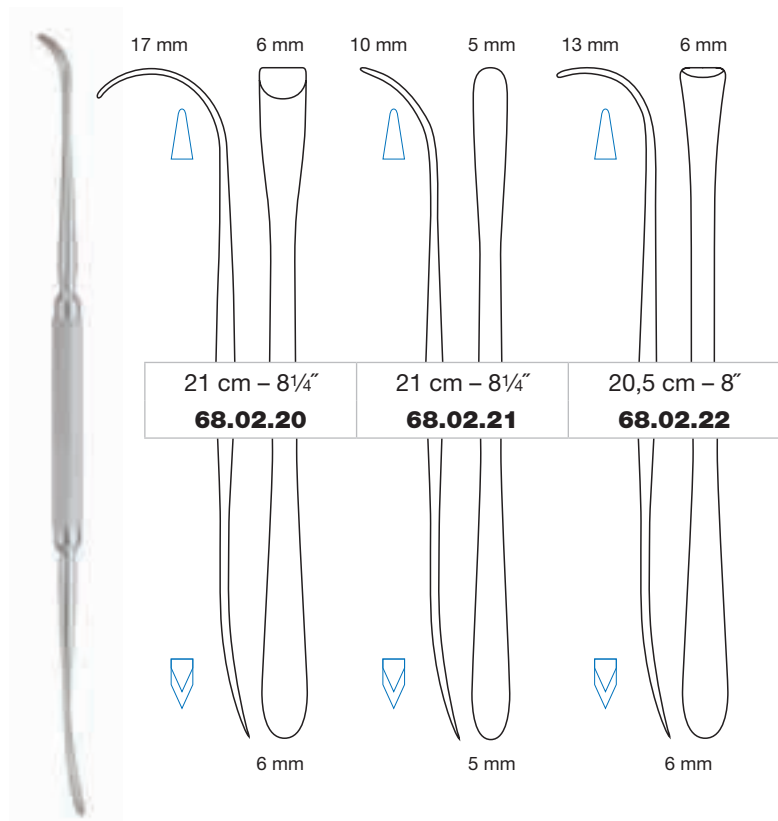
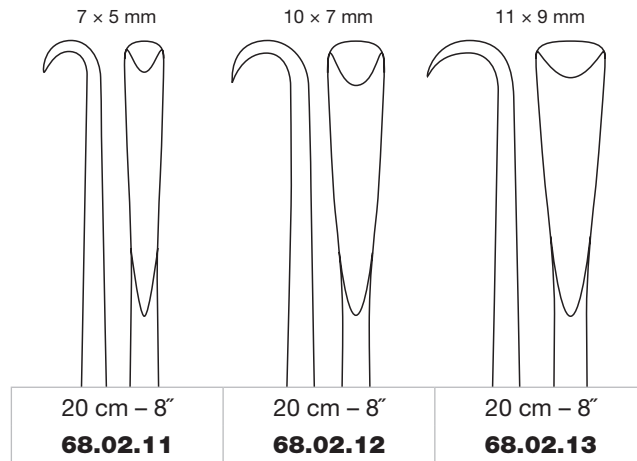

Obwegeser-Freer

scharf
sharp
cortante
tranchant
tagliente

stumpf
blunt
roma
mousse
smussa



B06

Raspatorien
Raspatories
Legras
Rugines
Periostotomi

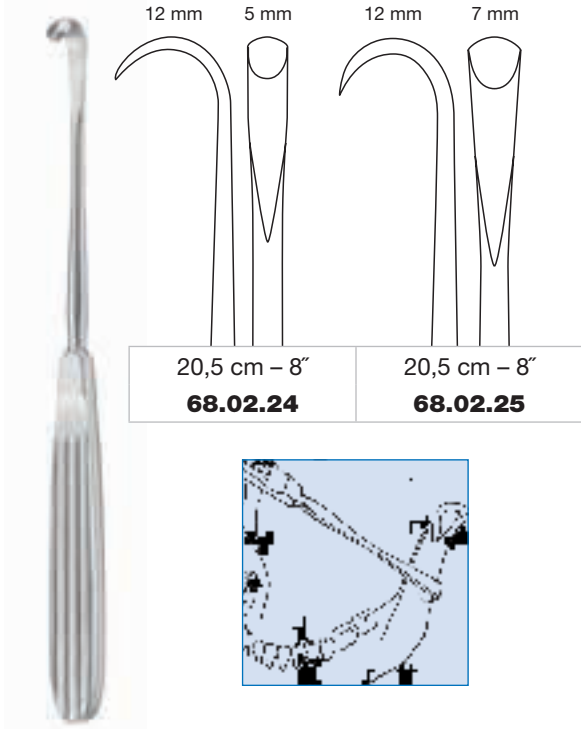

Obwegeser

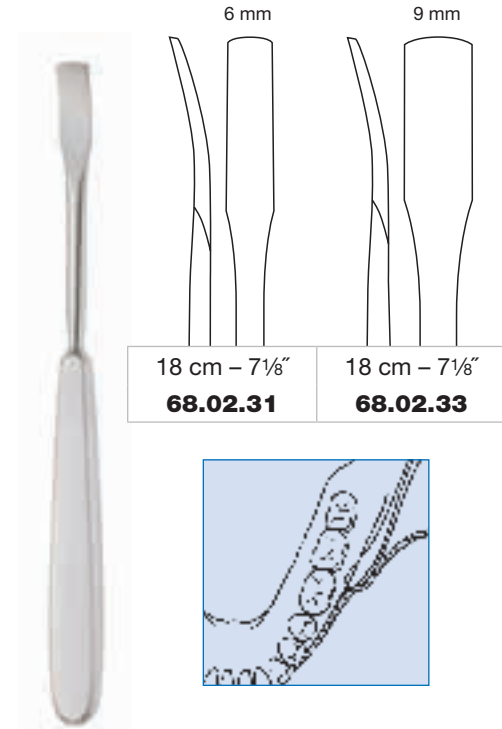

Obwegeser

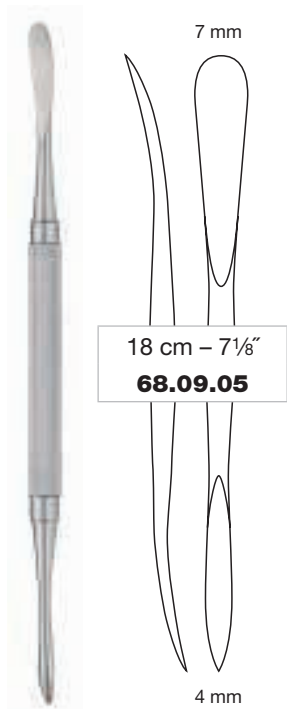

Dingman

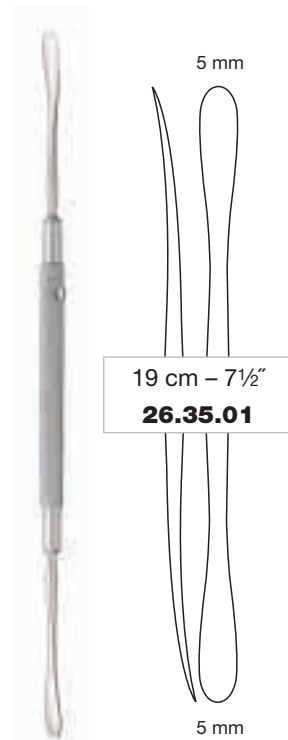

Freer

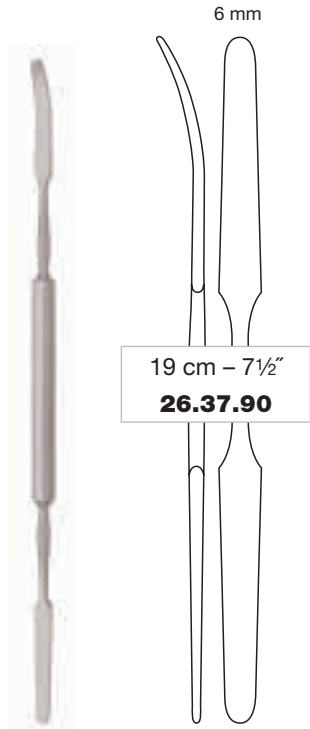

MacDonald

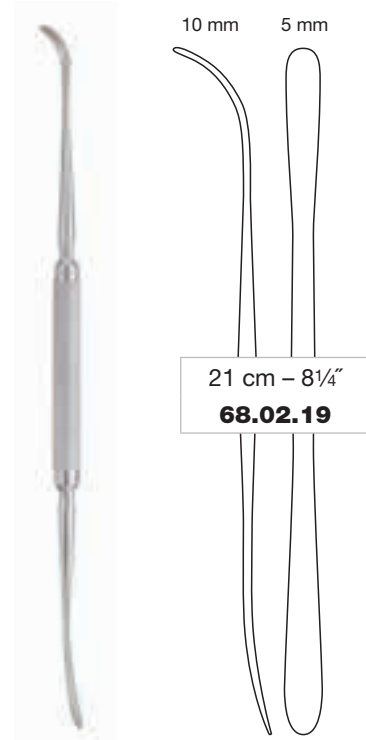

Obwegeser-Freer

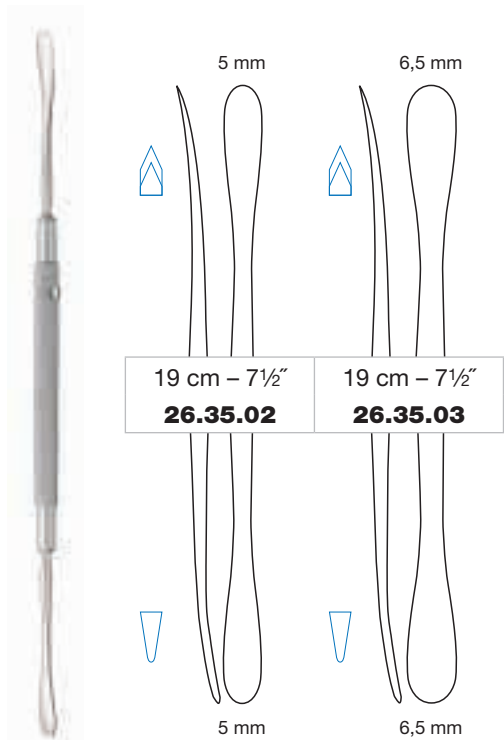

Freer

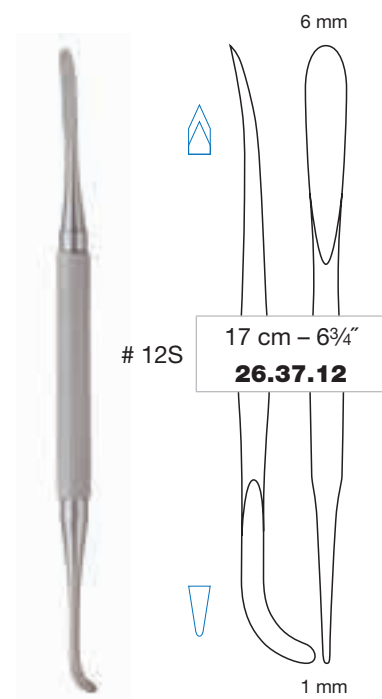

Bennet

19 cm – 7½"
26.37.90

21 cm – 8¼"
68.02.19

19 cm – 7½"
26.35.02

19 cm – 7½"
26.35.03

12S
17 cm – 6¾"
26.37.12



scharf
sharp
cortante
tranchant
tagliante



stumpf
blunt
roma
mousse
smussa



B06

**Elevatori
Elevators
Elevadores
Elévateurs
Elevatori**



Adson

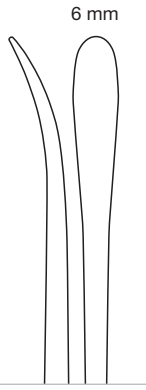

6 mm

17 cm - 6¾"
26.48.02



Langenbeck

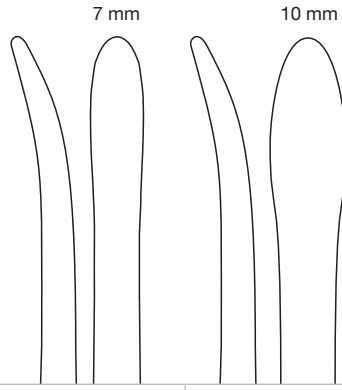

7 mm

10 mm

20 cm - 8"
26.29.07

20 cm - 8"
26.29.10



Dingman

21 cm - 8¼"
68.09.20

für Jochbogen
for zygomatic arch
para arco cigomático
pour arcade cygomatique
per arco zigomatico



Gillies

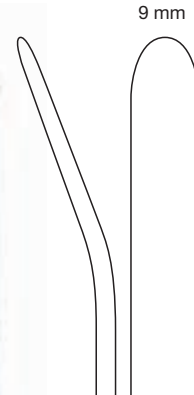

9 mm

23 cm - 9"
68.45.10

Scharfe Löffel
Sharp Curettes
Cucharillas cortantes
Curettes tranchantes
Cucchiai taglienti

B07

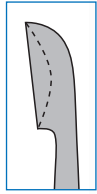

Volkmann

# 0000	# 000	# 00	# 0	# 1
17 cm – 6¾"	17 cm – 6¾"	17 cm – 6¾"	17 cm – 6¾"	17 cm – 6¾"
29.51.24	29.51.33	29.51.42	29.51.50	29.51.51
# 2	# 3	# 4	# 5	# 6
17 cm – 6¾"	17 cm – 6¾"	17 cm – 6¾"	17 cm – 6¾"	17 cm – 6¾"
29.51.52	29.51.53	29.51.54	29.51.55	29.51.56

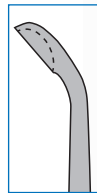

Daubenspeck

# 00	# 0
20 cm – 8"	20 cm – 8"
29.68.42	29.68.50
# 1	# 2
20 cm – 8"	20 cm – 8"
29.68.51	29.68.52



B07

Hämmer
Mallets
Martillos
Maillets
Martelli



Hajek

21 cm – 8¼"	27.04.20	200 g	Ø 26 mm
-------------	-----------------	-------	---------



18,5 cm – 7¼"	27.06.20	200 g	Ø 25 mm
---------------	-----------------	-------	---------



27.06.21

Ersatzbacken, Paar
Replacement discs, pair
Frentes de repuesto, par
Joues de rechange, paire
Guancie di ricambio, paio

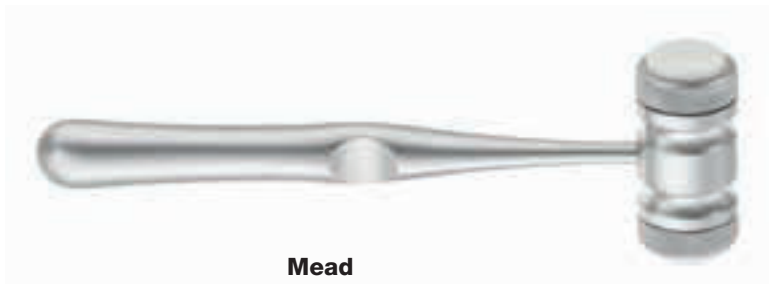

Mead

18 cm – 7⅞"	27.06.30	300 g	Ø 26 mm
-------------	-----------------	-------	---------



27.06.31

Ersatzbacken, Paar
Replacement discs, pair
Frentes de repuesto, par
Joues de rechange, paire
Guancie di ricambio, paio



26 cm – 10¼"	27.10.31	150 g	Ø 35 mm
26 cm – 10¼"	27.10.32	240 g	Ø 45 mm
26 cm – 10¼"	27.10.33	330 g	Ø 50 mm



Kunststoff (autoklavierbar bis 134 °C bei 3 bar)
Plastic (autoclavable up to 134 °C at 3 bar)
Plástico (autoclavable hasta 134 °C bajo presión de 3 bar)
Plastique (autoclavable à 134 °C sous pression de 3 bars)
Plastica (autoclavabile fino a 134 °C sotto pressione di 3 bar)



Kunststoffbacken (abschraubbar)
Plastic discs (screw-on type)
Frentes de material plástico (destornillables)
Joues en matière plastique (dévissables)
Guancie di plastica (svitabili)

Flachmeißel
 Chisels
 Cinceles
 Ciseaux burins
 Scalpelli

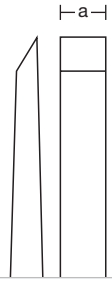
	14 cm – 5½"
a = 2 mm	27.61.02
a = 3 mm	27.61.03
a = 4 mm	27.61.04
a = 6 mm	27.61.06
a = 8 mm	27.61.08

Partsch

	16 cm – 6¼"
a = 4 mm	27.92.04
a = 6 mm	27.92.06
a = 8 mm	27.92.08
a = 10 mm	27.92.10

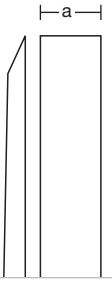
Brünings

Flachmeißel
 Chisels
 Cinceles
 Ciseaux burins
 Scalpelli

	13 cm – 5⅛"
a = 2 mm	27.57.02
a = 4 mm	27.57.04
a = 6 mm	27.57.06
a = 8 mm	27.57.08
a = 10 mm	27.57.10
a = 12 mm	27.57.12
a = 15 mm	27.57.15

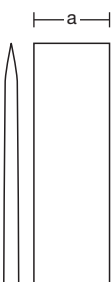
Mini-Lambotte

Satz komplett
 Set complete
 Juego completo
 Série complète
 Serie completa

27.57.90



B07

**Osteotome
Osteotomes
Osteótomos
Ostéotomes
Osteotomi**



Cottle-Medicon

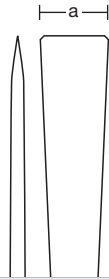

18 cm – 7 1/8"	
a = 4 mm	27.64.04
a = 7 mm	27.64.07
a = 9 mm	27.64.09
a = 12 mm	27.64.12

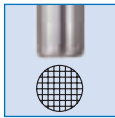

mit Knochenstopfer
with bone tamper
con pisón para huesos
avec poussoirs à os
con impattatori per ossa



Lambotte

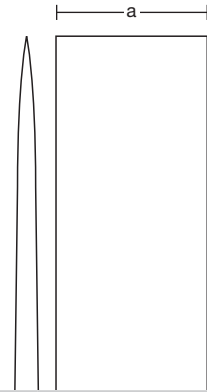

24 cm – 9 1/2"	
a = 4 mm	28.94.04
a = 6 mm	28.94.06
a = 8 mm	28.94.08
a = 10 mm	28.94.10
a = 12 mm	28.94.12
a = 15 mm	28.94.15
a = 20 mm	28.94.20
a = 25 mm	28.94.25
a = 30 mm	28.94.30
a = 40 mm	28.94.40
a = 44 mm	28.94.44
a = 50 mm	28.94.50

Interdentale Osteotome
Interdental osteotomes
Osteótomos interdentaes
Ostéotomes interdentaes
Osteotomi interdentali



Obwegeser



15 cm – 6"	
a = 2,5 mm	68.03.02
a = 4,0 mm	68.03.04
a = 6,5 mm	68.03.39



Silver

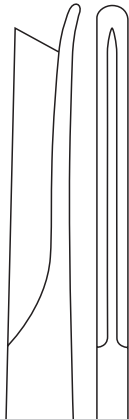

18 cm – 7 1/8"
67.38.10

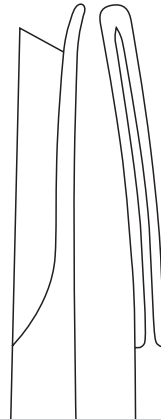

18 cm – 7 1/8"
67.38.11



18 cm – 7 1/8"
67.38.12

Rechte Seite
Right side
Lado derecho
Côté droite
Lato destro

Linke Seite
Left side
Lado izquierdo
Côté gauche
Lato sinistro

Knochenheber und Spaltosteotom
Bone lever and splitting osteotome
Elevador óseo y osteótomo hendedor
Levier à os et ostéotome à fendre
Elevatore per ossa e osteotomo per splittaggio



Cottle

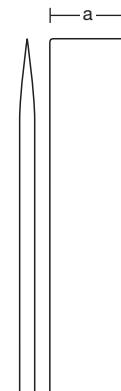

20 cm – 8"
a = 10 mm **67.32.80**



B07

Osteotome
Osteotomes
Osteótomos
Ostéotomes
Osteotomi

Spaltosteotome
Splitting osteotomes
Osteótomos hendedores
Ostéotomes à fendre
Osteotomi per splittaggio osseo



Obwegeser

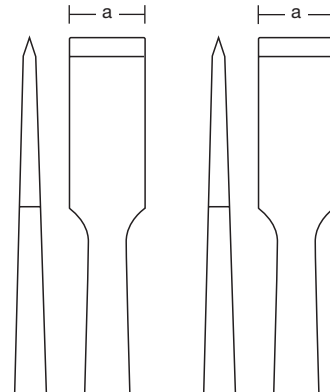

	21,5 cm – 8½"	21,5 cm – 8½"
a = 7 mm	68.03.07P	68.03.07
a = 10 mm	68.03.10P	68.03.10



PROPYLUX

- ▶ Ein biokompatibler Kunststoff der neuesten Thermoplast-Generation
- ▶ Extrem formbeständig bei häufiger Autoklavierung
- ▶ A biocompatible plastic from the latest generation of thermoplastics
- ▶ Extremely high dimensional stability even when frequently autoclaved
- ▶ Un plástico biocompatible de la última generación de termoplásticos
- ▶ Extremadamente resistente a deformaciones en esterilizaciones en autoclave frecuentes
- ▶ Un plastique biocompatible de la toute dernière génération des thermoplastiques
- ▶ Extrêmement résistant aux déformations en cas de passages fréquents à l'autoclave
- ▶ Una plastica biocompatibile di una generazione più recente della termoplastica
- ▶ Estremamente resistente a deformazioni anche con trattamento frequente in autoclave

NOVOTEX

- ▶ Ein duroplastischer Kunststoff aus der Familie der Phenoplaste
- ▶ Sehr hart und bruchbeständig
- ▶ Thermosetting plastics of the range of phenol formaldehyde resins
- ▶ Very hard and break resistant
- ▶ Plástico termoendurecible de la familia de resina fenol-formaldehído
- ▶ Muy duro y resistente a la rotura
- ▶ Plastique thermodurcissable de la famille des résines phénol-formaldéhyde
- ▶ Très dur et résistant à la casse
- ▶ Materia plastica termoindurente della famiglia di resine fenoliche
- ▶ Molto duro e resistente alla rottura



Kunststoffgriff (autoklavierbar bis 134 °C bei 3 bar)
Plastic handle (autoclavable up to 134 °C at 3 bar)
Mango de plástico (autoclavable hasta 134 °C bajo presión de 3 bar)
Manche en plastique (autoclavable à 134 °C sous pression de 3 bars)
Manico di plastica (autoclavabile fino a 134 °C sotto pressione di 3 bar)

Keilosteotome
Wedge osteotomes
Osteótomos de cuña
Ostéotomes cunéiformes
Osteotomi a forma di cuneo



Obwegeser

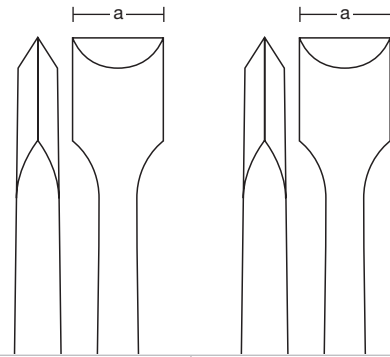

	22 cm – 8¾"	22 cm – 8¾"
a = 8 mm	68.03.12P	68.03.12
a = 12 mm	68.03.13P	68.03.13
a = 16 mm	68.03.14P	68.03.14



Blattosteotome
Blade osteotomes
Osteótomos de hoja
Ostéotomes en lame
Osteotomi a forma di lama

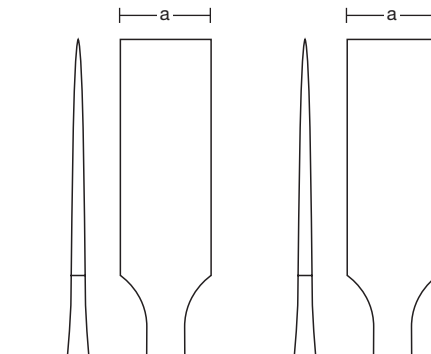

22 cm – 8¾"	22 cm – 8¾"	
68.03.16P	68.03.16	a = 8 mm
68.03.17P	68.03.17	a = 12 mm
68.03.18P	68.03.18	a = 16 mm
68.03.19P	68.03.19	a = 20 mm



Obwegeser



Kunststoffgriff (autoklavierbar bis 134 °C bei 3 bar)
Plastic handle (autoclavable up to 134 °C at 3 bar)
Mango de plástico (autoclavable hasta 134 °C bajo presión de 3 bar)
Manche en plastique (autoclavable à 134 °C sous pression de 3 bars)
Manico di plastica (autoclavabile fino a 134 °C sotto pressione di 3 bar)



B07

Osteotome
Osteotomes
Osteótomos
Ostéotomes
Osteotomi



Cinelli

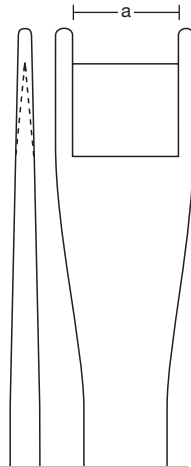

16 cm – 6¼"	
a = 10 mm	67.37.10
a = 12 mm	67.37.12
a = 14 mm	67.37.14
a = 16 mm	67.37.16



Blume

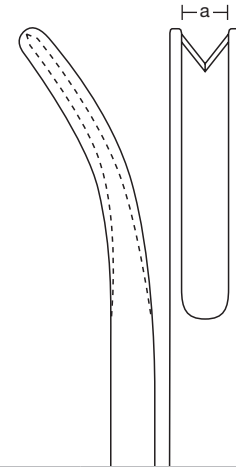

18 cm – 7⅛"	
a = 6 mm	67.37.20

für die laterale Osteotomie
for lateral osteotomy
para la osteotomía lateral
pour l'ostéotomie latérale
per la osteotomia laterale



Tessier

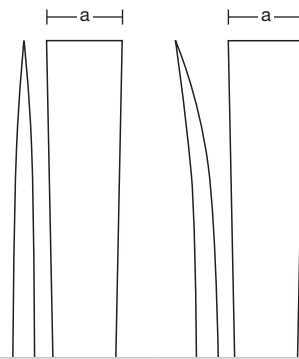

20,5 cm – 8"		20,5 cm – 8"	
a = 10 mm	68.03.50	a = 10 mm	68.03.51
a = 15 mm	68.03.52	a = 15 mm	68.03.53

Tuber Osteotome
Pterygoid osteotomes
Osteótomos pterigoideo
Ostéotomes pterigoïde
Osteotomi pterigoideo



Obwegeser

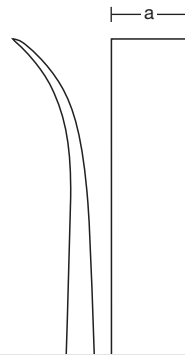

	23 cm – 9"
a = 8 mm	68.03.31
a = 10 mm	68.03.30
a = 11 mm	68.03.32



Obwegeser

flexibel
flexible
flexible
flexible
flessibile

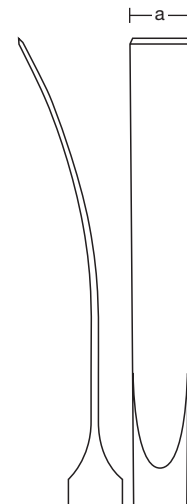

	21 cm – 8¼"
a = 8 mm	68.03.34
a = 10 mm	68.03.35



B07

Nasenseptum-Osteotome und Mobilisator
Nasal Septum Osteotomes and Mobilizer
Osteótomos para el tabique nasal y movilizador
Ostéotomes pour cloison nasale et mobilisateur
Osteotomi per setto nasale e mobilizzatore

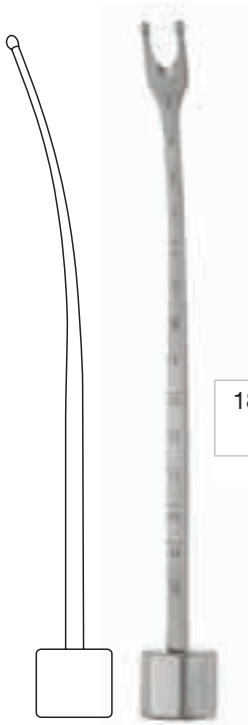

Obwegeser

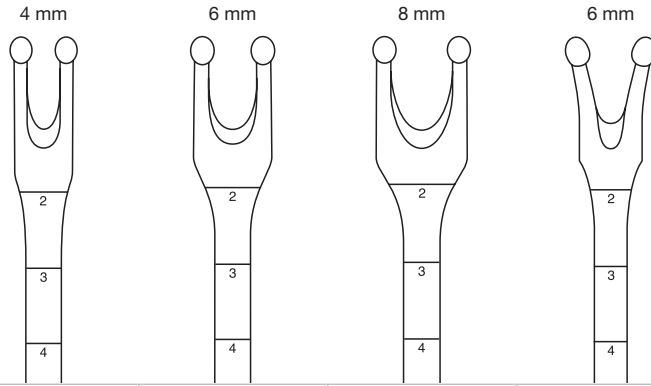

18,5 cm – 7¼"	18,5 cm – 7¼"	18,5 cm – 7¼"	18,5 cm – 7¼"
68.03.71	68.03.72	68.03.73	68.03.76



Maxilla-Mobilisator
Maxilla mobilizer
Movilizador maxilar
Mobilisateur pour maxillaire
Mobilizzatore per mascella

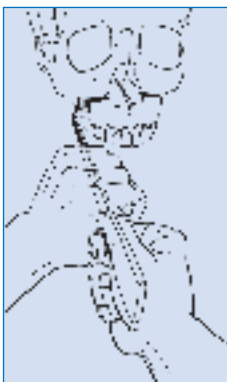

Obwegeser

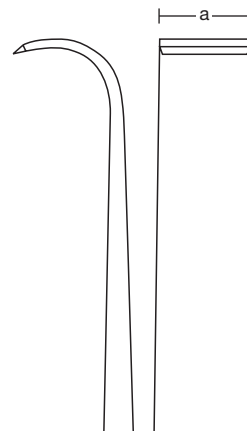

	23 cm – 9"
a = 12 mm	68.03.29

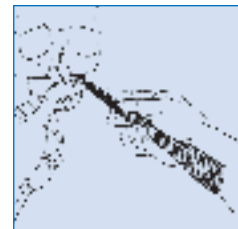

Positionierer und Fragment-Adaptierungsklemmen
Positioner and Fragment Adapting Forceps
Posicionador y pinzas adaptadoras para fragmentos
Positionneur et clamps d'adaptation de fragments osseux
Posizionatore e pinze d'adattamento per frammenti

B07

Positionierer
 Positioner
 Posicionador
 Positionneur
 Posizionatore



Wangerin



18 cm - 7 1/8"

68.05.20

Fragment-Adaptierungsklemmen
 Fragment adapting forceps
 Pinzas adaptadoras para fragmentos
 Clamps d'adaptation de fragments osseux
 Pinze d'adattamento per frammenti

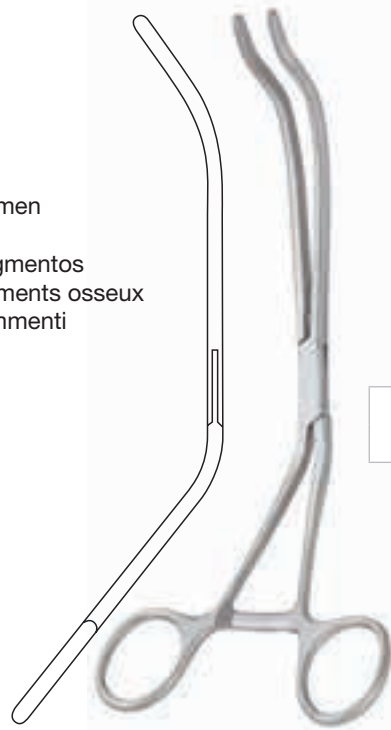

Obwegeser

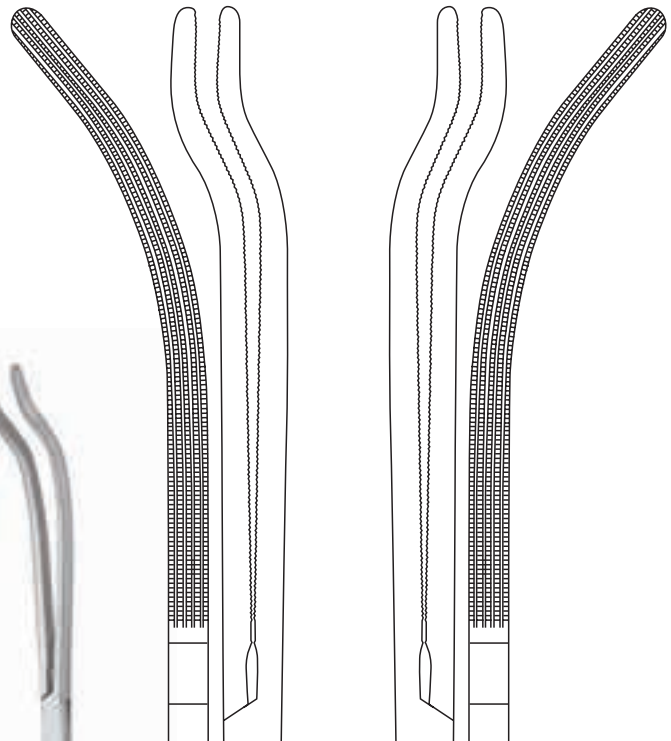

19,5 cm - 7 3/4"

68.40.01

Linke Seite
 Left side
 Lado izquierdo
 Côté gauche
 Lato sinistro

19,5 cm - 7 3/4"

68.40.02

Rechte Seite
 Right side
 Lado derecho
 Côté droite
 Lato destro



B07

Repositionszangen und Mobilisierhaken
Reposition Forceps and Mobilizing Retractors
Pinzas para reposicionar y separadores de movilización
Pinces à réposition et crochets à mobilisation
Pinze per riposizione e divaricatori per mobilizzazione



Repositionszangen
 Reposition forceps
 Pinzas para reposicionar
 Pinces à réposition
 Pinze per riposizione

für Oberkiefer
 for upper jaw
 para mandíbula superior
 pour mâchoire supérieure
 per mascella superiore



Rowe

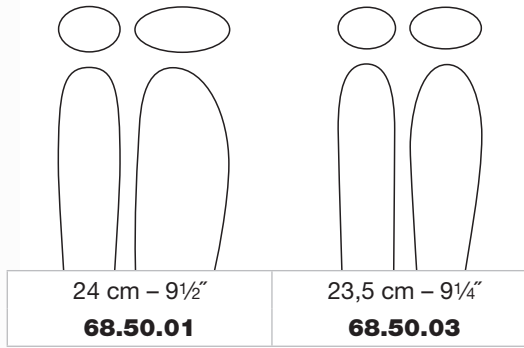

Linke Seite
 Left side
 Lado izquierdo
 Côté gauche
 Lato sinistro

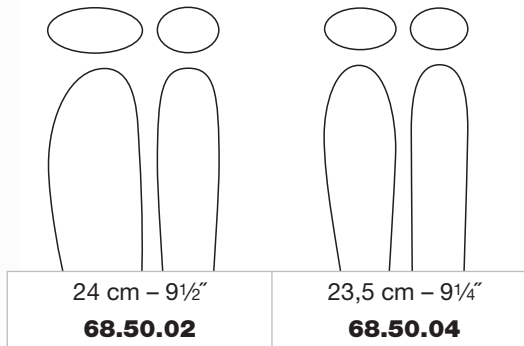

Rechte Seite
 Right side
 Lado derecho
 Côté droite
 Lato destro

Mobilisierhaken
 Mobilizing retractors
 Separadores de movilización
 Crochets à mobilisation
 Divaricatori per mobilizzazione

für Unterkiefer
 for lower jaw
 para mandíbula inferior
 pour mâchoire inférieure
 per mascella inferiore



Tessier

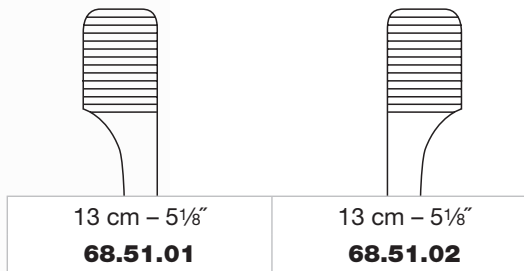

Linke Seite
 Left side
 Lado izquierdo
 Côté gauche
 Lato sinistro

Rechte Seite
 Right side
 Lado derecho
 Côté droite
 Lato destro

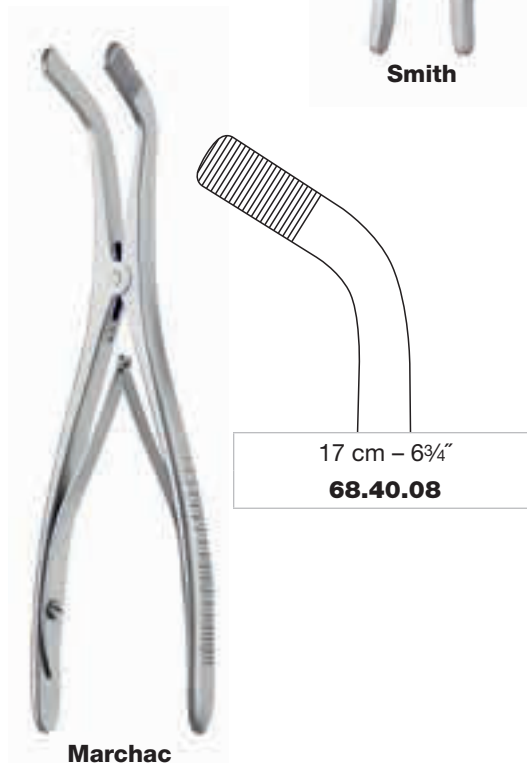



B07

Knochenhaltezangen
Bone Holding Forceps
Pinzas prensoras de huesos
Daviers à os
Tenaglie per ossa

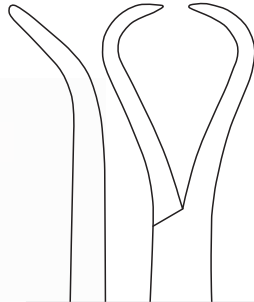

13,5 cm - 5 $\frac{3}{8}$ "
35.11.13

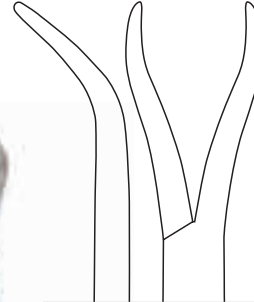

13,5 cm - 5 $\frac{3}{8}$ "
35.11.14



Dingman

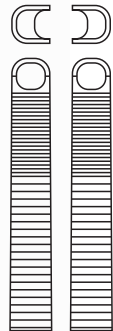

19 cm - 7 $\frac{1}{2}$ "
35.15.18

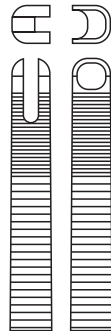

19 cm - 7 $\frac{1}{2}$ "
35.15.19

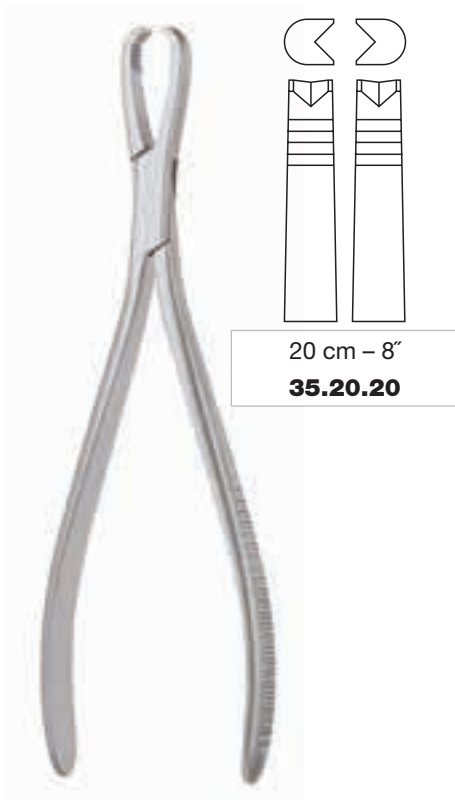



B07

Knochensplitterzangen
Bone Cutting Forceps
Pinzas cortantes para huesos
Pinces coupantes à os
Pinze ossivore



Ruskin-Liston



18 cm - 7 1/8"	18 cm - 7 1/8"
33.56.18	33.57.18



McIndoe



17 cm - 6 3/4"
33.59.17

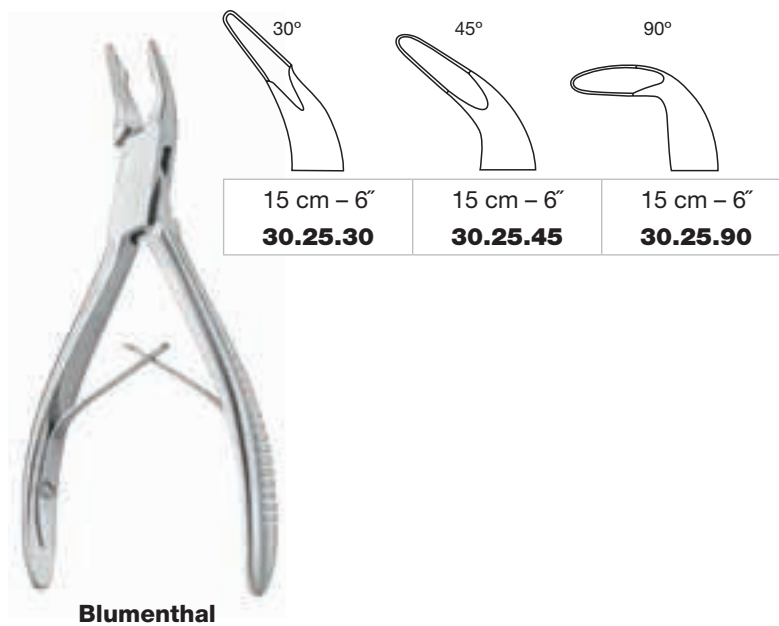
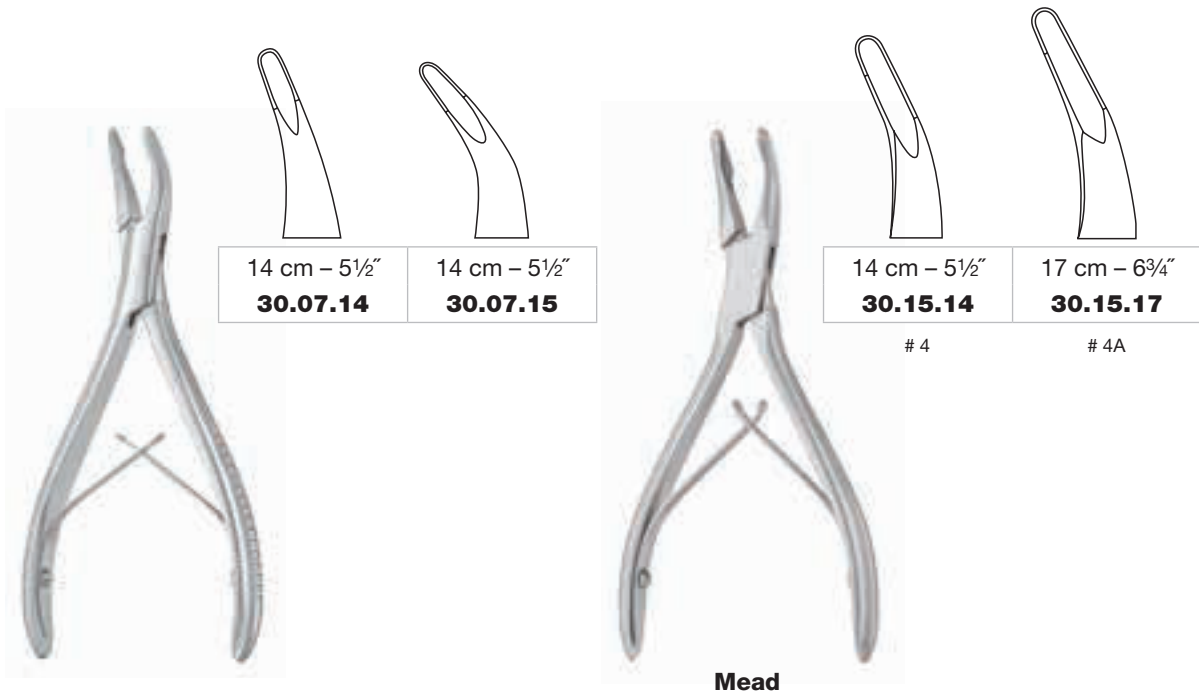



B07

Hohlmeißelzangen
 Bone Rongeurs
 Pinzas gubias
 Pincés-gouges
 Pinze sgorbie



Luer



15 cm – 6"
30.30.15



15 cm – 6"
30.30.35



Beyer



17 cm – 6¾"
30.71.02



17 cm – 6¾"
30.71.03



Stellbrink



17 cm – 6¾"
30.76.17



17 cm – 6¾"
30.76.18



Ruskin-Mini



15 cm – 6"
31.04.02



15 cm – 6"
31.04.03



15 cm – 6"
31.05.02



15 cm – 6"
31.05.03



Ruskin



24 cm – 9½"
31.06.25



24 cm – 9½"
31.07.25



B07

Hohlmeißelzangen
Bone Rongeurs
Pinzas gubias
Pincis-gouges
Pinze sgorbie



Ruskin



18 cm – 7 1/8"
31.06.05



18 cm – 7 1/8"
31.07.05



Beyer



18 cm – 7 1/8"
31.11.04



Zaufal-Jansen



18 cm – 7 1/8"
31.11.05



Marquardt



20 cm – 8"
31.11.13

drehbar
 rotatable
 giratoria
 rotatif
 girevole

Stanzbreite Jaw width Ancho del corte Largeur des mors Larghezza de morso	
	5 mm
a	90° b = 16 cm - 6 1/2"
3 mm	66.38.10

Hajek-Kofler

Stanzbreite Jaw width Ancho del corte Largeur des mors Larghezza de morso		
	6,5 mm	6,5 mm
a	90° b = 13 cm - 5 1/8"	90° b = 13 cm - 5 1/8"
3,5 mm	66.38.21	66.38.22
4,0 mm	66.38.31	66.38.32

Hajek



B07

Nasenzangen
Nasal Forceps
Pinzas nasales
Pinces nasales
Pinze nasali

Nasenzangen mit normalem Schaft
 Nasal forceps with normal shaft
 Pinzas nasales con vástago normal
 Pinces nasales à tige normale
 Pinze nasali con asta normale

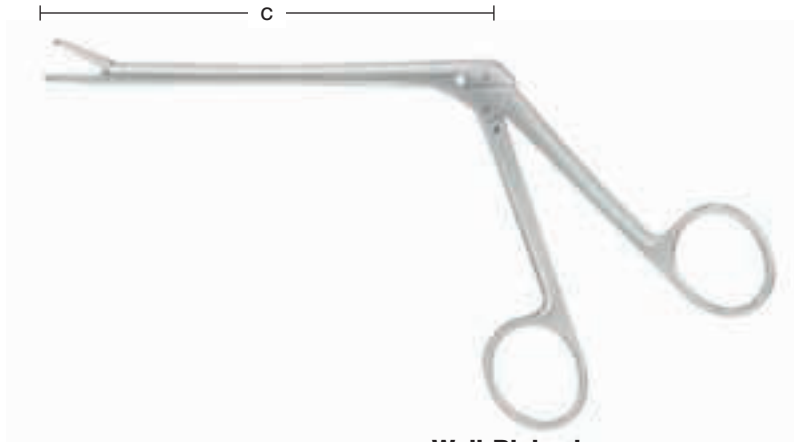
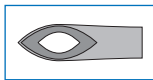

Weil-Blakesley

		gerade straight recta droit retta	aufgewinkelt angled upwards angulada hacia arriba coudé en haut angolata verso l'alto	aufgewinkelt angled upwards angulada hacia arriba coudé en haut angolata verso l'alto	
Maulbreite Jaw width Ancho de la boca Largeur des mors Larghezza del morso	Maullänge Jaw length Longitud de la boca Longueur des mors Lunghezza del morso				
a	b	c = 12 cm - 4¾"	45° c = 12 cm - 4¾"	90° c = 12 cm - 4¾"	
# 1	3,0 mm	10 mm	66.28.01	66.28.11	66.28.31
# 2	3,6 mm	10 mm	66.28.02	66.28.12	66.28.32
# 3	4,2 mm	10 mm	66.28.03	66.28.13	66.28.33
# 4	4,8 mm	10 mm	66.28.04	66.28.14	66.28.34
# 5	5,6 mm	10 mm	66.28.05		



Nasenzangen mit schlankem Schaft
Nasal forceps with slim shaft
Pinzas nasales con vástago delgado
Pincas nasales à tige élancée
Pinze nasali con asta sottile

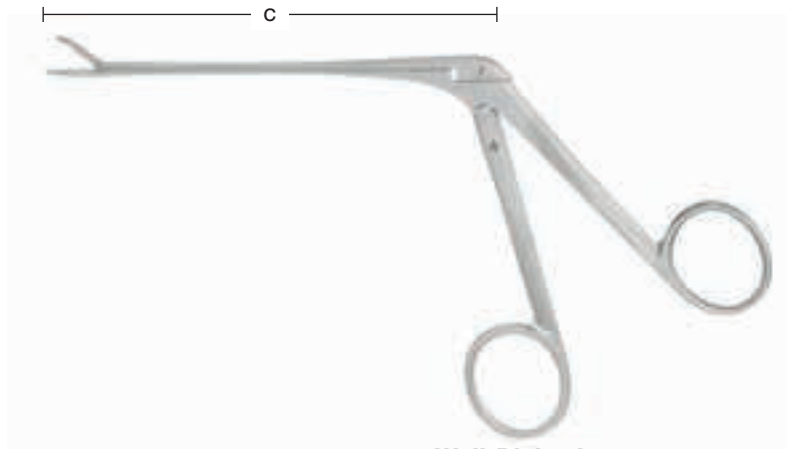
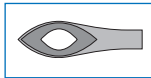

Weil-Blakesley

				gerade straight recta droit retta	aufgewinkelt angled upwards angulada hacia arriba coudé en haut angolata verso l'alto
		Maulbreite Jaw width Ancho de la boca Largeur des mors Larghezza del morso a	Maullänge Jaw length Longitud de la boca Longueur des mors Lunghezza del morso b		
				c = 12 cm - 4¾"	45° c = 12 cm - 4¾"
# 1	3,0 mm	10 mm		66.28.71	66.28.81
# 2	3,6 mm	10 mm		66.28.72	66.28.82
# 3	4,2 mm	10 mm		66.28.73	66.28.83
# 4	4,8 mm	10 mm		66.28.74	66.28.84
# 5	5,6 mm	10 mm		66.28.75	



B07

Knochenstopfer und Blutstillungsmeißel
Bone Tampers and Hemostatic Chisels
Pisón para huesos y cinceles para hemostasia
Poussoirs à os et ciseaux burins pour hémotase
Impattatori per ossa e scalpelli per emostasi



Knochenstopfer
 Bone tampers
 Pisón para huesos
 Poussoirs à os
 Impattatori per ossa



Ø 3 mm	Ø 5 mm
16 cm – 6¼"	16 cm – 6¼"
27.95.03	27.95.05
Ø 7 mm	Ø 9 mm
16 cm – 6¼"	16 cm – 6¼"
27.95.07	27.95.09

Blutstillungsmeißel
 Hemostatic chisels
 Cinceles para hemostasia
 Ciseaux burins pour hémotase
 Scalpelli per emostasi



Passow

3,0 mm	3,5 mm
12 cm – 4¾"	12 cm – 4¾"
27.95.11	27.95.12

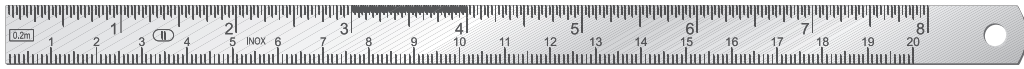

Stahllineale (rostfrei)
Rulers (stainless steel)
Reglas de acero (inoxidable)
Règles en acier (inoxydable)
Righelli in acciaio (inossidabile)

15 cm – 6"	44.37.15
20 cm – 8"	44.37.20
30 cm – 11¾"	44.37.30
50 cm – 19¾"	44.37.50

graduiert in mm und Zoll
graduated in mm and inches
graduado en mm y pulgadas
graduée en mm et pouces
graduato in mm e pollici



Röntgen-Lineal (rostfrei)
X-ray ruler (stainless steel)
Regla radiografica (inoxidable)
Règle pour radiographie (inoxydable)
Righello per radiografia (inossidabile)

50 cm – 19¾"	44.37.95
--------------	-----------------

mit Kerben und graduiert in mm
with notches and graduated in mm
con muesca y graduado en mm
avec encoches et graduée en mm
con incavature e graduato in mm



Winkelmesser
Flexometer
Goniómetro
Goniomètre
Goniometro

23,5 cm – 9¼"	44.38.10
---------------	-----------------

zusammenlegbar
fold up
plegable
pliable
pieghevole

Möltgen



Knochenmesszirkel
Bone measuring dividers
Compás para hueso
Compas à os
Compasso per ossa

19,5 cm – 7¾"	44.38.40
---------------	-----------------



Referenz-Pin und Instrumente für die Le Fort I-Osteotomie
Reference Pin and Instruments for Le Fort I Osteotomy
Perno de referencia e instrumentos para osteotomía de Le Fort I
Pivot de référence et instruments pour ostéotomie de Le Fort I
Perno di referenza e strumenti per osteotomia di Le Fort I

KRETSCHMER REFERENCE PIN



Der Referenz-Pin ist für den Einsatz während Operationen in der Mund-, Kiefer-, und Gesichtschirurgie speziell zum Einbringen in die Glabella entwickelt. Er ist für die mono- und bimaxilläre Umstellungsosteotomie zur vertikalen Referenzmessung konzipiert worden.

The reference pin is especially intended for insertion into the glabella during operations in the fields of oral and maxillofacial surgery. It was designed for monomaxillary and bimaxillary correction osteotomy for vertical reference measurement.

El perno de referencia ha sido desarrollado especialmente para ser colocado en la glabella durante operaciones de cirugía maxilofacial. Ha sido concebido para la medición de la referencia vertical en la osteotomía de avance monomaxilar y bimaxilar.

Le pivot de référence est conçu pour une utilisation dans le cadre des interventions de chirurgie buccale et maxillo-faciale, et plus précisément pour une insertion dans la glabelle. Il est destiné à l'ostéotomie correctrice mono- et bimaxillaire pour la réalisation de mesures de référence verticales.

Il perno di riferimento è stato sviluppato per la chirurgia oromaxillofaciale, in particolare per l'applicazione sulla glabella. È stato concepito per l'osteotomia correttiva mono e bimascellare per la misurazione dei riferimenti verticali.



Vorteile
Advantages
Ventajas
Avantages
Vantaggi

- ▶ Exakte Ermittlung der vertikalen Dimensionen
- ▶ Keine Irritationen des Referenzpunktes während der OP
- ▶ Einfache und exakte Endkontrolle der gewünschten vertikalen Position vor und während der Fixation
- ▶ Precise determination of vertical dimensions
- ▶ No irritation of the reference point during surgery
- ▶ Easy and precise final checking of the desired vertical position before and during fixation
- ▶ Determinación precisa de las dimensiones verticales
- ▶ Ningún tipo de irritación del punto de referencia durante la intervención quirúrgica
- ▶ Sencillez y precisión de los controles finales de la posición vertical deseada, antes y durante la fijación
- ▶ Détermination précise des dimensions verticales
- ▶ Aucune irritation du point de référence pendant l'intervention chirurgicale
- ▶ Simplicité et précision des contrôles finaux de la position verticale désirée, avant et pendant la fixation
- ▶ Determinazione precisa delle dimensioni verticali
- ▶ Nessuna irritazione del punto di referenza durante l'intervento chirurgico
- ▶ Controllo finale semplice e preciso della posizione verticale desiderata, prima e durante la fissazione



Referenz-Pin
 Reference pin
 Perno de referencia
 Pivot de référence
 Perno di referenza



Kretschmer

20 mm

68.84.00



Die Instrumente sind nicht proportional dargestellt.
 The instruments are not illustrated proportionally.
 Los instrumentos no están representados proporcionalmente.
 Les instruments sont représentés à une échelle différente.
 Gli strumenti non sono rappresentati in proporzione.



Verpackungseinheit "X" Stück
 Packing unit "X" pieces
 Paquete de "X" unidades
 Emballage de "X" pièces
 Confezione da "X" pezzi



Referenz-Pin und Instrumente für die Le Fort I-Osteotomie
Reference Pin and Instruments for Le Fort I Osteotomy
Perno de referencia e instrumentos para osteotomía de Le Fort I
Pivot de référence et instruments pour ostéotomie de Le Fort I
Perno di referenza e strumenti per osteotomia di Le Fort I

B08

Stahllineal (rostfrei)
 Ruler (stainless steel)
 Regla de acero (inoxidable)
 Règle en acier (inoxydable)
 Riga in acciaio (inossidabile)

graduiert in mm und Zoll
 graduated in mm and inches
 graduado en mm y pulgadas
 graduée en mm et pouces
 graduata in mm e pollici



20 cm - 8" **44.37.20**

Knochenmesszirkel
 Bone bow spacer
 Compás para hueso
 Compas à os
 Compasso per ossa



19,5 cm - 7¾" **44.38.40**

Chirurgische Handstücke für Motorensysteme
 Surgical hand pieces for motor systems
 Piezas de mano quirúrgicas para sistemas de motor
 Pièces à main chirurgical pour systèmes de moteur
 Manipoli chirurgici per sistemi di motore

Halterungen für Referenz-Pin
 Holders for reference pin
 Soportes para perno de referencia
 Supports pour pivot de référence
 Sostegni per perno di referenza



9 cm - 3½" **63.45.44**



Kretschmer
 30 mm **68.84.04**



8,5 cm - 3⅜" **63.45.07**



Kretschmer
 16 mm **68.84.05**



11 cm - 4⅜" **63.45.11**



Kretschmer
 66 mm **68.84.06**

13 cm - 5⅛" **63.45.13**

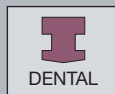

Ansatz
 Shank end
 Talón
 Embout
 Attacco



Ansatz
 Shank end
 Talón
 Embout
 Attacco



B08

Messzirkel
Calipers
Compasses
Compas
Compassi



20 mm



8 cm – 3 1/8"
60.00.40

Castroviejo

40 mm

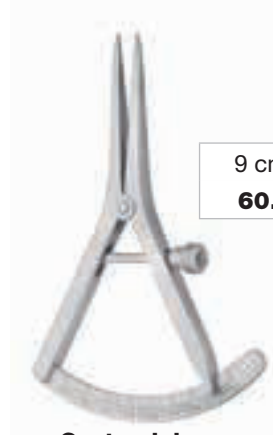

9 cm – 3 1/2"
60.00.41

Castroviejo

40 mm



18 cm – 7 1/8"
60.00.42

Castroviejo-Epker

40 mm



18 cm – 7 1/8"
60.00.43

Castroviejo-Epker



Messbereich
Measuring range
Alcance de medición
Etendue de mesure
Campo di misura

Drahtbogen
Arch bar
Arco de alambre
Arc en fil
Arco di filo



Erich

1 m
68.15.05

Drahtbogen
Arch bar
Arco de alambre
Arc en fil
Arco di filo

1:1



Erich

14 cm – 5½" **68.15.10** P₁₂

Drähte (weich)
Wires (soft)
Alambres (dulces)
Fils (souple)
Fili (dolce)



● max. Ø 0,3 mm (29 G)	10 m	76.01.03
● max. Ø 0,4 mm (27 G)	10 m	76.01.04
● max. Ø 0,5 mm (25 G)	10 m	76.01.05



B09

Drahtinstrumente
Wire Instruments
Instrumentos para alambre
Instruments pour fils
Strumenti per fili



Drahtinstrumente
Wire instruments
Instrumentos para alambre
Instruments pour fils
Strumenti per fili



Luniatschek

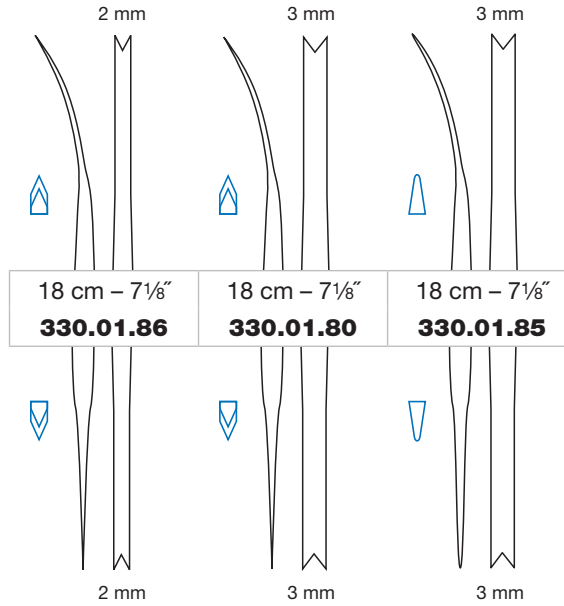

Drahtpositionierer
Wire pusher
Instrumento para posicionar alambre
Positionneur à fil
Posizionatore per filo

Flachzange
Flat nose pliers
Alicate plano
Pince plate
Tenaglia piatta



14 cm – 5 1/2"
14.46.14



Mershon

14,5 cm – 5 3/4"
68.15.50



scharf
sharp
cortante
tranchant
tagliente



stumpf
blunt
romo
mousse
smussa

Drahtdrehklemme
 Wire twister
 Pinza para torcer alambre
 Pince à torsader le fil
 Pinza per torcere fili





 13 cm – 5 1/8"
68.04.73

Obwegeser "HM"

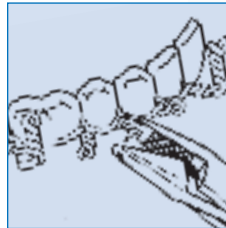
Drahtösenklemme
 Wire loop forceps
 Pinza para ojetas de alambre
 Pince pour œillets en fil métallique
 Pinza occhiello per filo metallico

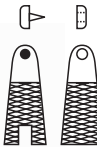



 15,5 cm – 6 1/8"
68.04.76

Obwegeser

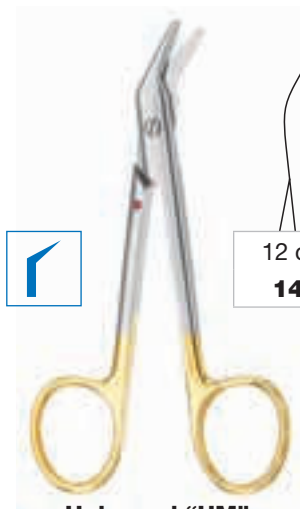
Drahtschere
 Wire cutting scissors
 Tijera para cortar alambre
 Ciseaux coupe-fil
 Forbice per fili d'acciaio



 12 cm – 4 3/4"
14.23.62

Universal "HM"

max.
 Ø 0,3 mm

Harte Drähte
 Hard wires
 Alambres duros
 Fils durs
 Fili duri

max.
 Ø 0,8 mm

Weiche Drähte
 Soft wires
 Alambres blandos
 Fils mous
 Fili dolci

"HM"

Hartmetall
 Tungsten carbide
 Carburo de tungsteno
 Carbure de tungstène
 Carburo di tungsteno



seitwärts gewinkelt
 angled to side
 acodada lateralmente
 coudés latéralement
 angolata lateralmente



Eine Schneide gezahnt
 One blade serrated
 Una hoja dentada
 Une lame dentelée
 Una lama dentellata



B09

Drahtinstrumente Wire Instruments Instrumentos para alambre Instruments pour fils Strumenti per fili

Drahtschneidezangen
Wire cutting pliers
Alicate para cortar alambre
Pincers coupe-fils
Pinze per tagliare fili

max. Ø
Harte Drähte
Hard wires
Alambres duros
Fils durs
Fili duri

max. Ø
Weiche Drähte
Soft wires
Alambres blandos
Fils mous
Fili dolci

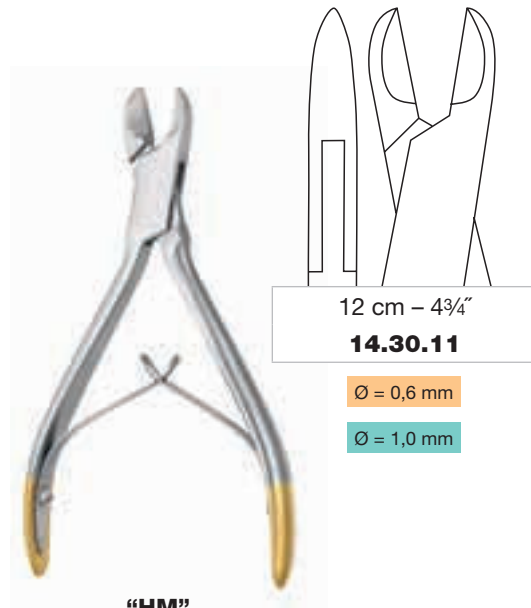

“HM”

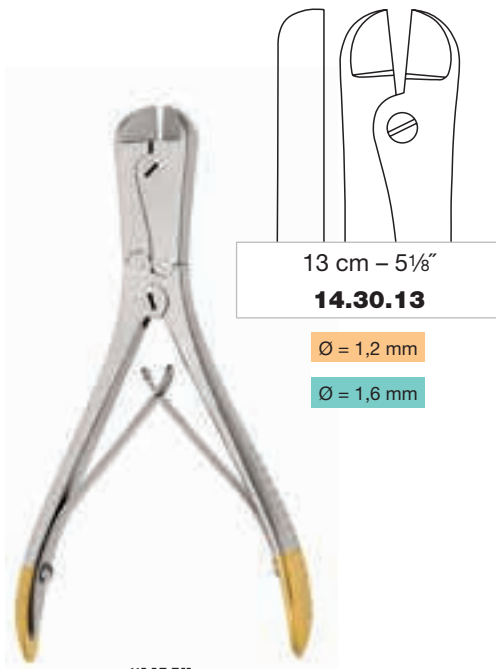

“HM”

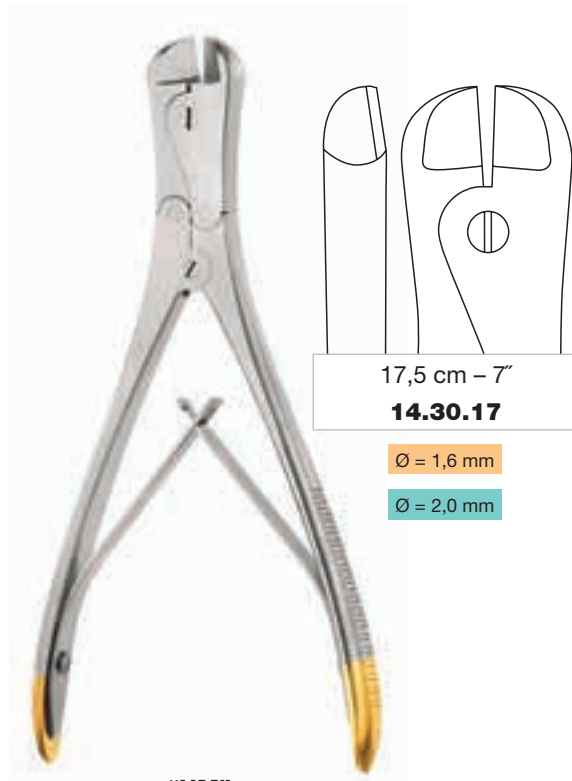

“HM”



“HM”
Hartmetall
Tungsten carbide
Carburo de tungsteno
Carbure de tungstène
Carburo di tungsteno

Ahle
Awl
Lezna
Alène
Punteruolo



für Unterkiefer
for lower jaw
para mandíbula inferior
pour mâchoire inférieure
per la mandibola



14 cm – 5½"

68.04.05

Obwegeser

Ahle
Awl
Lezna
Alène
Punteruolo



für Jochbogen
for zygomatic arch
para arco cigomático
pour arcade cygomatique
per il zigomo



23 cm – 9"

68.04.10

Obwegeser

Ahle
Awl
Lezna
Alène
Punteruolo

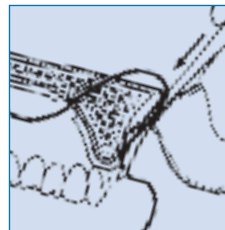

für Oberkiefer
for upper jaw
para mandíbula superior
pour mâchoire supérieure
per la mascella superiore



18 cm – 7¼"

68.04.15

Obwegeser

“KÖLN” MOUTH GAG

Mundsperrerr
 Mouth gag
 Abreboca
 Ouvre-bouche
 Apribocca

- ▶ Zahnhaken, gebogen
- ▶ Geringe Traumatisierung der Mundwinkel
- ▶ Verbesserte Sicht

- ▶ Tooth hooks, curved
- ▶ Less traumatization of corners of the mouth
- ▶ Improved visibility

- ▶ Ganchos dentales, curvados
- ▶ Poco traumatismo de la comisura bucal
- ▶ Visión mejorada

- ▶ Crochets dentales, courbé
- ▶ Traumatisation des coins de bouche réduite
- ▶ Visibilité améliorée

- ▶ Uncini dentali, curvati
- ▶ Traumatizzazione ridotta nei angoli della bocca
- ▶ Vista migliore



Köln

45.52.30

Satz bestehend aus: Set consisting of: Juego compuesto por: Jeu composé de: Set composto da:	45.52.31	Rahmen mit 2 Zahnhaken (ohne Zungendrücker) Frame with 2 tooth hooks (without tongue depressors) Bastidor con 2 ganchos dentales (sin bajalenguas) Cadre avec 2 crochets dentaires (sans abaisse-langues) Telaio con 2 uncini dentali (senza abbassalingua)	1x
	45.57.11 72.08.11 72.08.12 72.08.13	Zungendrücker Tongue depressors Bajalenguas Abaisse-langues Abbassalingua	1x # 1 1x # 1 1x # 2 1x # 3



90-93



Zungendrücker (siehe Seite 90-93)
 Tongue depressors (see page 90-93)
 Bajalenguas (véase página 90-93)
 Abaisse-langues (voir page 90-93)
 Abbassalingua (vedi pagina 90-93)



451.03.01

Weitere Informationen finden Sie in unserem Sonderprospekt
 For further information please see our special brochure
 Informaciones adicionales se encuentran en nuestro folleto especial
 Vous trouverez de plus amples informations dans notre prospectus spécial
 Ulteriori informazioni si possono trovare sul nostro depliant speciale



siehe Seite
 see page
 véase página
 voir page
 vedi pagina

Lippen- und Gaumenspalteninstrumente
Lip and Cleft Palate Instruments
Instrumentos para labios y fisuras paladares
Instrumentos pour lèvres et fessures palatines
Strumenti per labbra e fessure del palato

B10

Häkchen
 Hooks
 Ganchitos
 Crochets
 Uncini

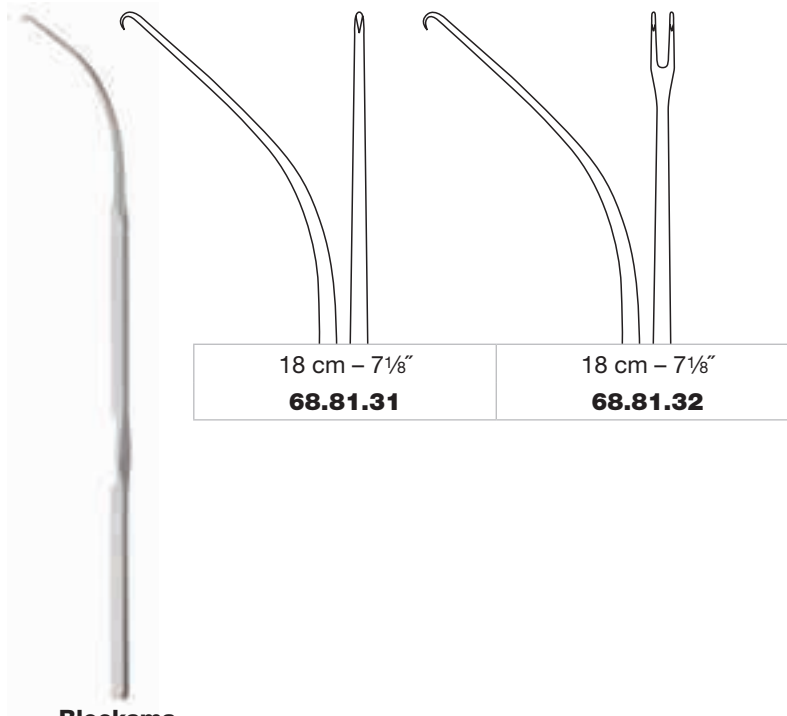

Blocksma

Elevatorium
 Elevator
 Elevador
 Elévateur
 Elevatore

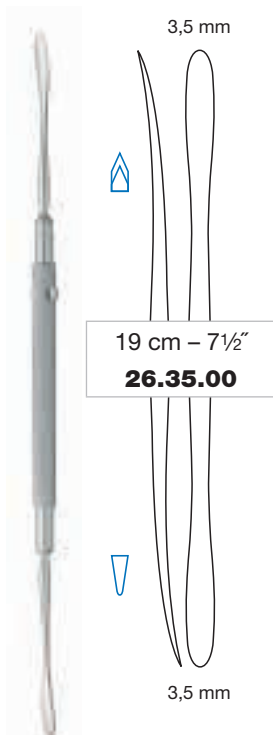

Freer-Scheer

Raspatorien
 Raspatories
 Legras
 Rugines
 Periostotomi

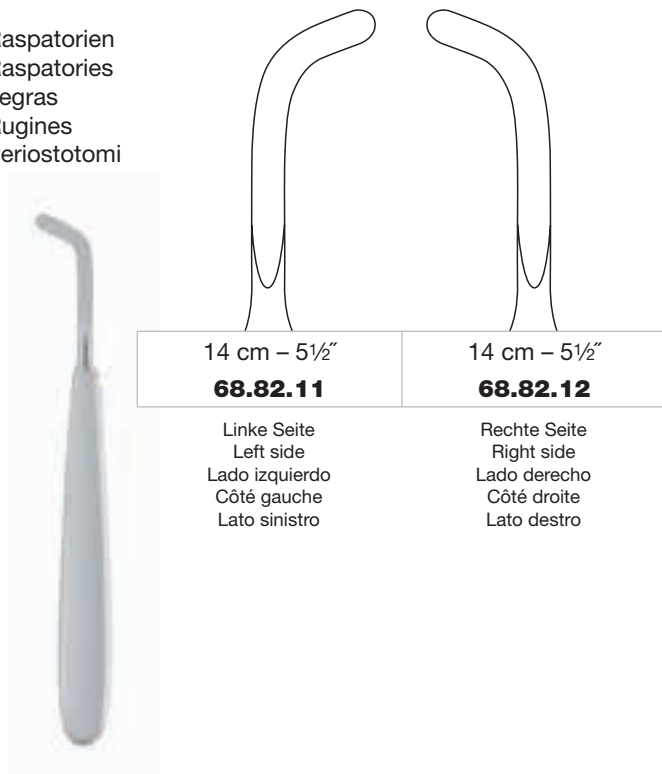

Linke Seite
 Left side
 Lado izquierdo
 Côté gauche
 Lato sinistro

Rechte Seite
 Right side
 Lado derecho
 Côté droite
 Lato destro

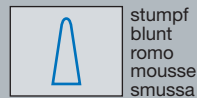



Lippen- und Gaumenspalteninstrumente
Lip and Cleft Palate Instruments
Instrumentos para labios y fisuras paladares
Instrumentes pour lèvres et fissures palatines
Strumenti per labbra e fessure del palato

B10



Raspatorien
 Raspatories
 Legras
 Rugines
 Periostotomi

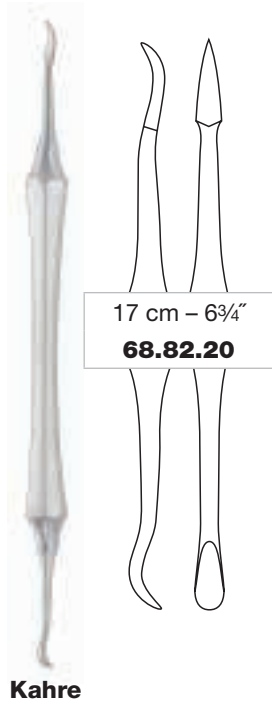

Kahre

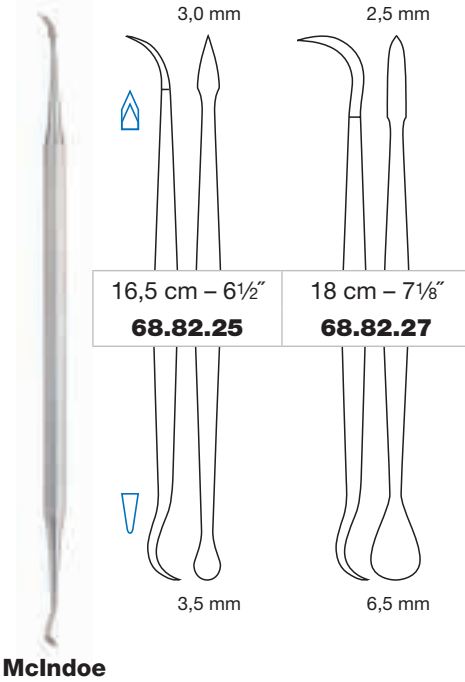

McIndoe

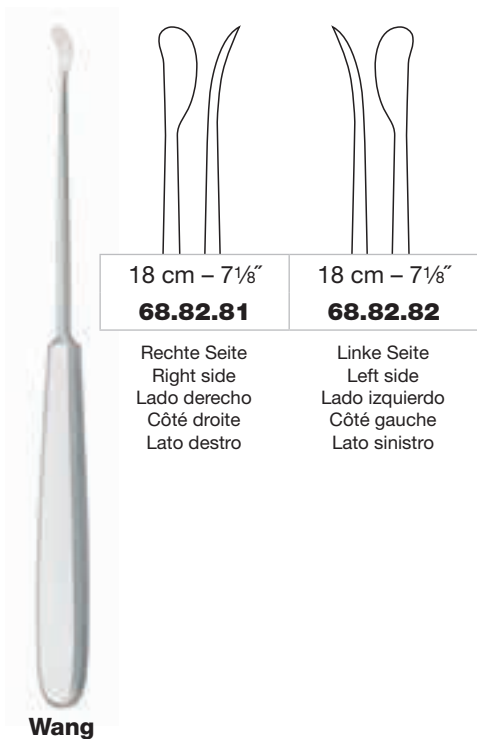

Wang

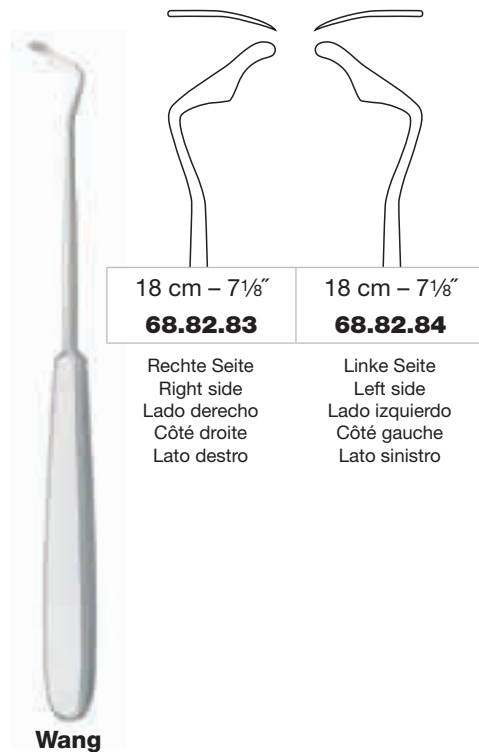

Wang



scharf
 sharp
 cortante
 tranchant
 tagliente

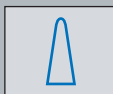

stumpf
 blunt
 romo
 mousse
 smussa

STILLER SINUSLIFTING SET

Das "Stiller-Sinuslifting"-Set wurde speziell für die Augmentationstechnik zum Knochenaufbau in Arealen der Seitenzähne im Oberkiefer bei zu geringem vertikalen Knochenangebot zusammengestellt.

The "Stiller-Sinuslifting" set was especially designed for bone augmentation in areas of the posterior teeth in the maxilla in case of an insufficient vertical bone supply.

El juego "Stiller-Sinuslifting" está compuesto especialmente para aumentar la estructura ósea en áreas de los dientes laterales superiores, en caso de una cantidad ósea demasiado reducida en el plano vertical.

Le jeu "Stiller-Sinuslifting" a été spécialement composé pour augmenter la formation osseuse dans les zones des dents latérales dans la mâchoire supérieure en cas de volume osseux vertical trop faible.

Il set "Stiller-Sinuslifting" è stato appositamente creato per un aumento del volume osseo in prossimità della zona posteriore del mascellare superiore, in caso di una quantità ridotta di osso in senso verticale.



Vorteile
Advantages
Ventajas
Avantages
Vantaggi

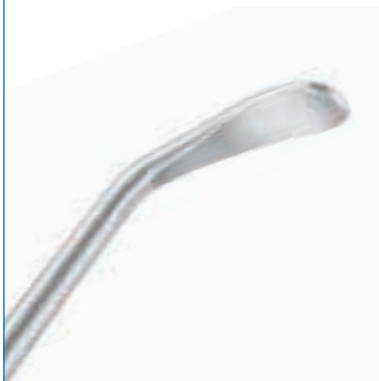

- ▶ Flexible Einsatzmöglichkeiten bei unterschiedlichen Bedingungen und individuellen Techniken
- ▶ Glänzende Arbeitskante am Paddel zur Reduktion des Präparations-traumas an der empfindlichen Sinusschleimhaut
- ▶ Flexible applications under various conditions and with individual techniques
- ▶ Shiny working edge at the paddle for reduction of preparation trauma on the sensitive sinus mucosa
- ▶ Posibilidades de aplicación flexible en condiciones distintas y con técnicas individuales
- ▶ Bordos de trabajo brillantes en la pala para reducir el trauma de la preparación en la sensible mucosa sinusal
- ▶ Des applications flexibles dans des conditions différentes et avec des techniques individuelles
- ▶ Arête de travail brillante sur l'embout pour réduire le traumatisme lié à la préparation sur la muqueuse sensible des sinus
- ▶ Possibilità di utilizzo flessibile, a diverse condizioni e tecniche individuali
- ▶ Spatola con bordi lucidi al fine di ridurre il trauma di preparazione a livello delle mucosa sinusale sensibile



01.30.38

09.83.07

26.37.08

68.82.53
 68.82.54
 68.82.55

68.82.56

68.82.57

68.82.58



B11

Sinuslifting-Instrumente
Sinuslifting Instruments
Instrumentos para sinus-lift
Instrumentes pour sinus-lift
Strumenti per sinus-lifting

STILLER SINUSLIFTING SET



Elevatorien
 Elevators
 Elevadores
 Elévateurs
 Elevatori



Stiller

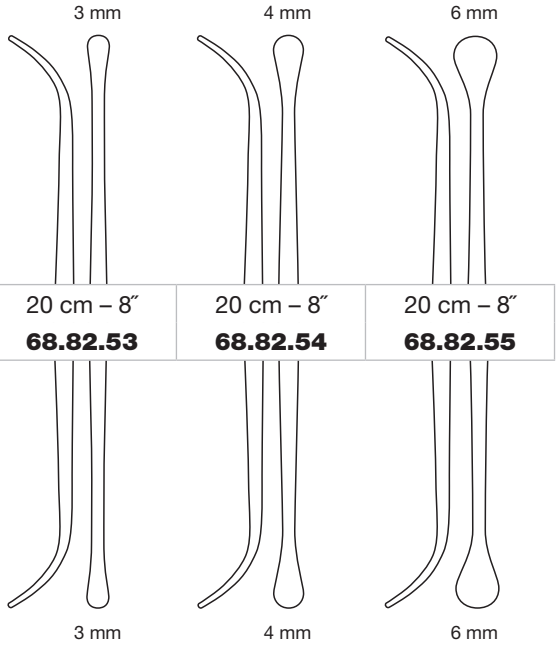

Elevatorien
 Elevators
 Elevadores
 Elévateurs
 Elevatori



Stiller

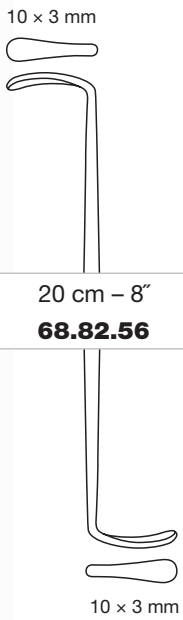

Stiller

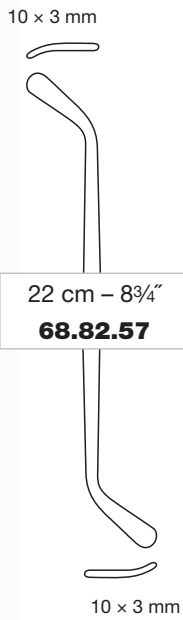

STILLER SINUSLIFTING SET

Komprimierer
Compressor
Compresor
Compresseur
Compressore

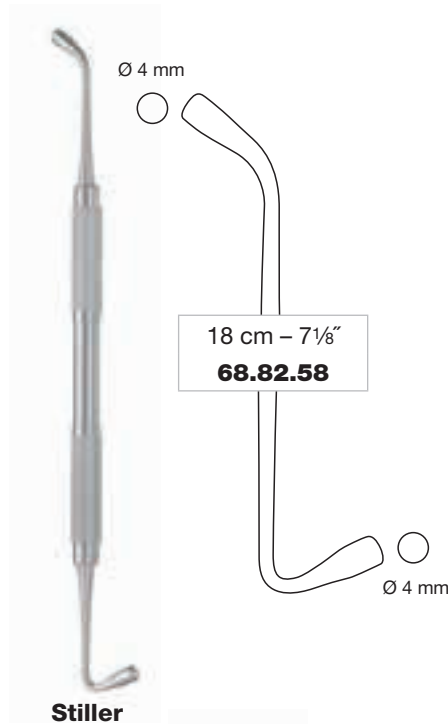

Raspatorium
Raspatory
Legra
Rugine
Periostotomo



Saugkanüle
Suction cannula
Cánula de aspiración
Canule à aspiration
Cannula per aspirazione



Skalpellsgriff
Scalpel handle
Mango de bisturí
Manche pour bistouris
Manico per bisturi

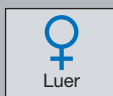

Schlauchverbindung (weiblich)
Tube connection (female)
Conexión de tubo (femenina)
Raccord de tuyau (féminine)
Raccordo per tubo (femminile)



mit Mandrin
with guide
con mandril
avec mandrin
con mandrino



B11

Sinuslifting-Instrumente
Sinuslifting Instruments
Instrumentos para sinus-lift
Instrumentes pour sinus-lift
Strumenti per sinus-lifting

Elevatorien
Elevators
Elevadores
Elévateurs
Elevatori

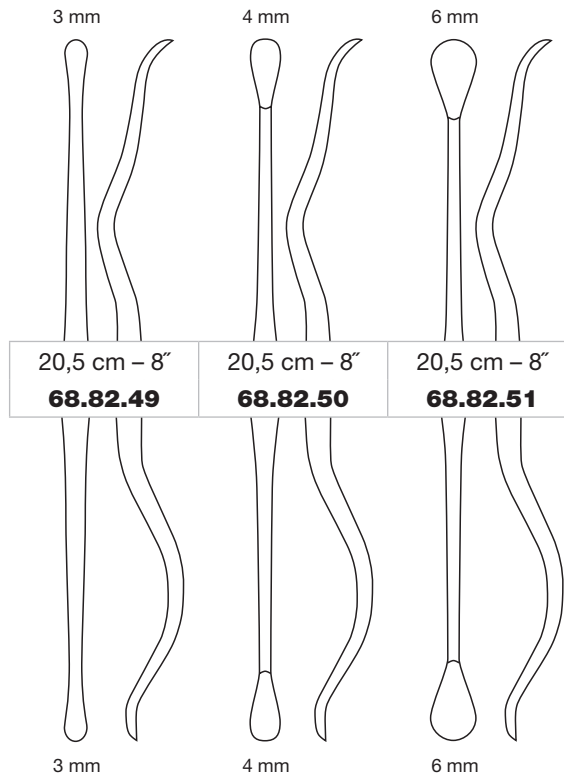

www.medicon.de

Einen Überblick über das MEDICON-Gesamtprogramm finden Sie im Internet.

For general information on the complete MEDICON product range please refer to the Internet.

Una vista general de la gama completa de productos MEDICON puede encontrar en el Internet.

Une vue d'ensemble de la gamme complète des produits MEDICON se trouve sur notre site Internet.

Una visione generale della completa gamma dei prodotti MEDICON è visibile sul nostro sito internet.



MEDICON

instruments

OMF - SURGERY

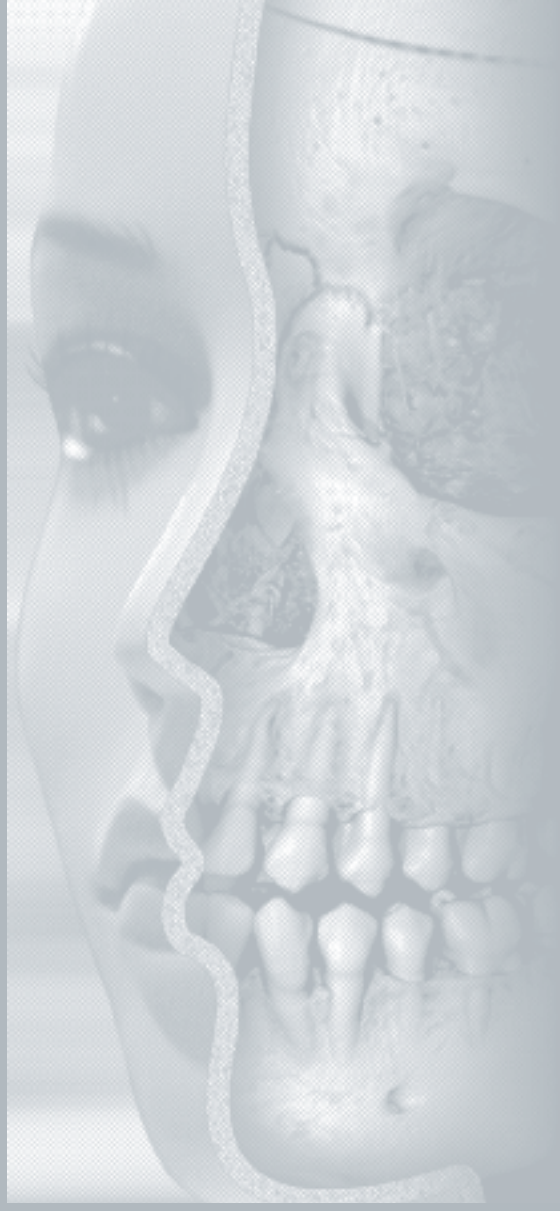



SPECIALITIES



C01

Spekulum zur Entfernung von Osteosynthesematerialien
Speculum for Removal of Osteosynthesis Materials
Espéculo para la remoción de implantes para la osteosíntesis
Spéculum pour l'enlèvement de matériel d'ostéosynthèse
Specolo per rimozione di mezzi di sintesi

KLUBA SPECULUM

Spekulum zur Entfernung von Osteosynthesematerialien
 Speculum for removal of osteosynthesis materials
 Espéculo para la remoción de implantes para la osteosíntesis
 Spéculum pour l'enlèvement de matériel d'ostéosynthèse
 Specolo per rimozione dei mezzi di osteosintesi

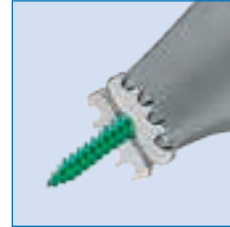

- ▶ Einfache Entnahme von Osteosynthesematerialien
- ▶ Patientenschonend - in Lokalanästhesie möglich
- ▶ Gutes ästhetisches Resultat

- ▶ Easy removal of osteosynthesis materials
- ▶ Gentle on patients - local anaesthetics possible
- ▶ Good esthetic result

- ▶ Remoción fácil de implantes para la osteosíntesis
- ▶ Buen cuidado del paciente gracias a la realización de la cirugía en anestesia local
- ▶ Buen resultado estético

- ▶ Enlèvement facile de matériel d'ostéosynthèse
- ▶ Bénin pour le patient - anesthésie local possible
- ▶ Bon résultat esthétique

- ▶ Semplice asportazione dei mezzi di osteosintesi
- ▶ Confortevole per il paziente - l'utilizzo è possibile in anestesia locale
- ▶ Ottimo risultato estetico

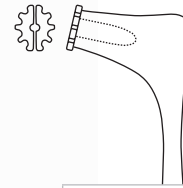

13,5 cm - 5 3/8"

66.01.20

1:1

Kluba



“X-CHANGE” NASAL RASPS



Die sehr flachen Raspelblätter sind einzeln ersetzbar und gewährleisten auf effiziente Weise immer ein scharfes Instrument.

The very flat, individually replaceable rasp blades are an efficient way of always ensuring a sharp instrument.

Las hojas de la raspa muy planas pueden ser utilizadas por separado y garantizan de forma eficaz que uno dispone siempre de un instrumento adecuadamente afilado.

Les lames de râpes sont interchangeables et disponibles à l'unité. Ce qui assure à l'instrument un parfait tranchant.

Gli inserti di raspa molto fine sono sostituibili singolarmente e garantiscono in modo efficace uno strumento sempre tagliente.

Handgriffe
Handles
Mangos
Manches
Manici



14 cm – 5½” 67.61.00	15 cm – 6” 67.61.01
--------------------------------	-------------------------------

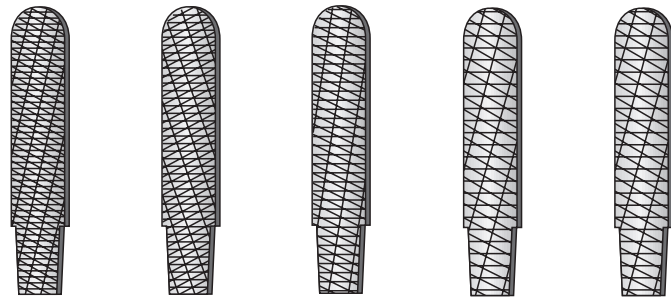

1:1

“HM”	# 1	# 2	# 3	# 4	# 5
	67.61.10	67.61.11	67.61.12	67.61.13	67.61.14

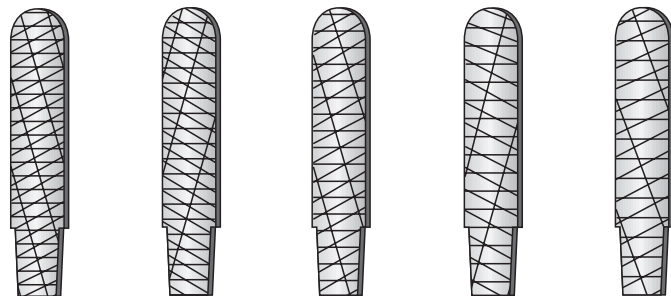

1:1

“HM”	# 6	# 7	# 8	# 9	# 10
	67.61.15	67.61.16	67.61.17	67.61.18	67.61.19



Schlüssel
Wrench
Llave
Clé
Chiave

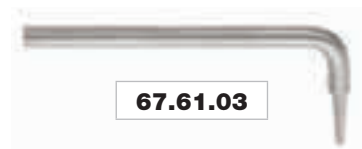

67.61.03

“HM” Hartmetall
Tungsten carbide
Carburo de tungsteno
Carbure de tungstène
Carburo di tungsteno



C03

Instrumente für den Beckenkamm
Instruments for the Pelvic Crest
Instrumentos para la cresta ilíaca
Instrumentos pour la crête iliaque
Strumenti per la cresta iliaca

“CRISTACA” - SET

Beckenkamm-Hohlmeißel
 Iliac crest graft gouge
 Gubia para cresta iliaca
 Gouge iliaque à transplant
 Sgorbia per cresta iliaca

mit Stopp
 with stop
 con stop
 avec stop
 con stop

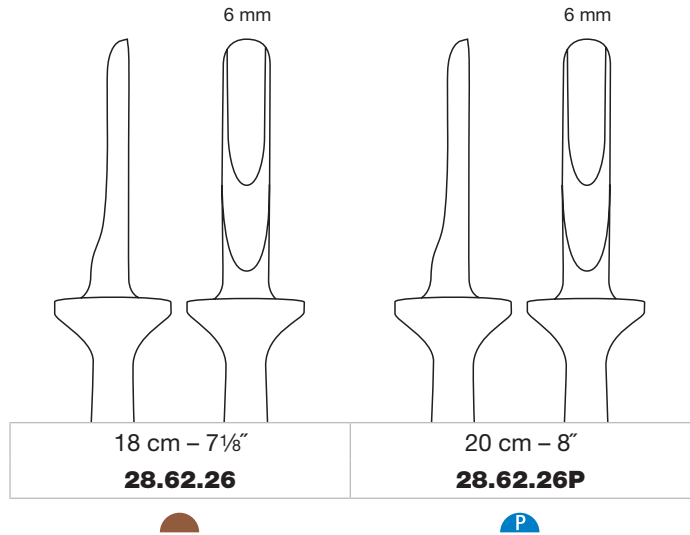

Beckenkamm-Löffel
 Iliac crest curette
 Cucharilla para la cresta ilíaca
 Curette pour la crête iliaque
 Cucchiario per la cresta iliaca

mit Stopp
 with stop
 con stop
 avec stop
 con stop



Kunststoffgriff (autoklavierbar bis 134 °C bei 3 bar)
 Plastic handle (autoclavable up to 134 °C at 3 bar)
 Mango de plástico (autoclavable hasta 134 °C bajo presión de 3 bar)
 Manche en plastique (autoclavable à 134 °C sous pression de 3 bars)
 Manico di plastica (autoclavabile fino a 134 °C sotto pressione di 3 bar)

“CRISTACA” - SET

Trepane
 Trephines
 Trepanos
 Trépan
 Trapani

mit Schaft-Durchmesser 2,35 mm
 with shaft diameter 2,35 mm
 con un diametro del vástago de 2,35 mm
 avec diamètre de manche de 2,35 mm
 con asta da 2,35 mm di diametro

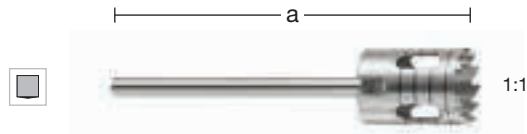

a = 44 mm	63.90.70	Ø 7 mm
a = 48 mm	63.90.80	Ø 10 mm

Bohrerstände
 Burr rack
 Caballete para broca
 Porte-forets
 Supporto perforatori

für 6 Bohrer bis 50 mm Länge
 for 6 burrs up to 50 mm length
 para 6 brocas hasta 50 mm de longitud
 pour 6 forets d'une longueur 50 mm
 per 6 perforatori fino a 50 mm di lunghezza



90 × 62 × 22 mm
46.35.22

Anmischbecher
 Mixing cup
 Vaso para mezclar
 Cupule à mélanger
 Scodella p miscelare

mit Deckel
 with lid
 con tapa
 avec couvercle
 con coperchio



3 cm – 1 1/8" (50 ml)
47.50.60



C03

Instrumente für den Beckenkamm
Instruments for the Pelvic Crest
Instrumentos para la cresta ilíaca
Instrumentos pour la crête iliaque
Strumenti per la cresta iliaca

“CRISTACA” - SET

Beckenkamm-Retraktoren
 Iliac crest retractors
 Separadores para cresta ilíaca
 Ecarteurs pour la crête iliaque
 Divaricatori per la cresta iliaca

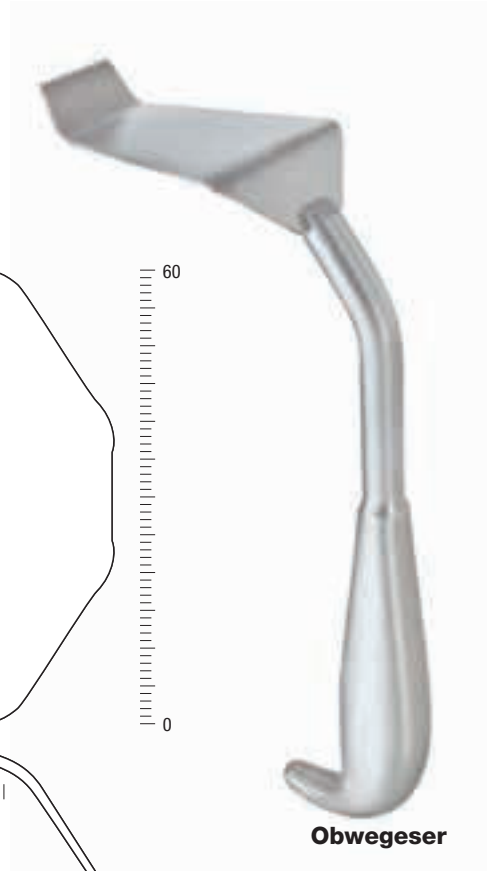
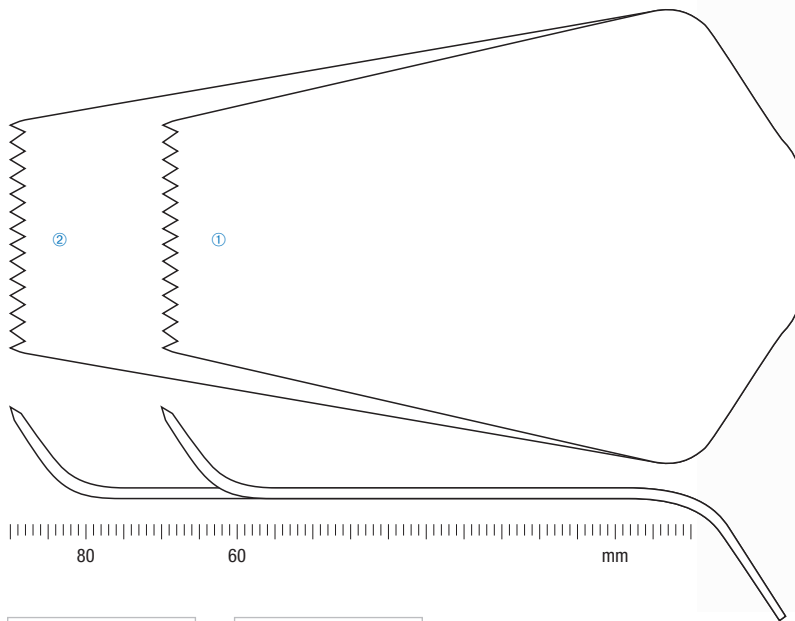
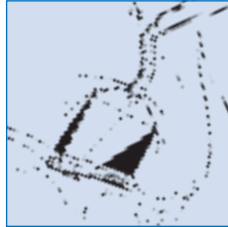

Obwegeser



①	a = 60 mm	b/c = 30/60 mm	22 cm – 8¾"	68.01.67
②	a = 80 mm	b/c = 30/60 mm	22 cm – 8¾"	68.01.68



451.06.90

Weitere Informationen finden Sie in unserem Sonderprospekt
 For further information please see our special brochure
 Informaciones adicionales se encuentran en nuestro folleto especial
 Vous trouverez de plus amples informations dans notre prospectus spécial
 Ulteriori informazioni si possono trovare sul nostro depliant speciale



SHEPARD CYLINDER OSTEOTOMES

Kortikalisstanze
 Cortical cutter
 Punzonadora cortical
 Perforateur cortical
 Perforatore corticale



Shepard		
12 cm – 4¾"	78.41.02	Ø 12 mm

Zylinder-Osteotome
 Cylinder osteotomes
 Osteotomos cilíndricos
 Ostéotomes cylindriques
 Osteotomi cilindrici



Shepard		
12,5 cm – 5"	78.41.05	Ø 5 mm
12,5 cm – 5"	78.41.06	Ø 6 mm
12,5 cm – 5"	78.41.08	Ø 8 mm

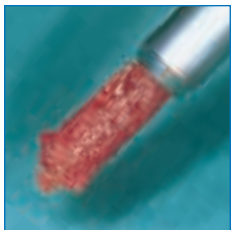

Querstift
 Cross pin
 Espiga transversal
 Embout transversal
 Perno trasversale



Shepard		
11 cm – 4¾"	78.41.11	Ø 6 mm

zum Drehen der Zylinder-Osteotome
 for turning cylinder osteotomes
 para girar osteotomos cilíndricos
 pour la rotation de l'ostéotome cylindrique
 per la rotazione degli osteotomi cilindrici



Ausstoßer
 Rams
 Expulsores
 Pousoirs
 Espulsori



Shepard		
14 cm – 5½"	78.41.12	Ø 5 mm
14 cm – 5½"	78.41.13	Ø 6 mm
14 cm – 5½"	78.41.14	Ø 8 mm



Trokare
 Trocars
 Trocares
 Trocart
 Trocar



Shepard		
14,5 cm – 5¾"	78.41.15	Ø 5 mm
14,5 cm – 5¾"	78.41.16	Ø 6 mm
14,5 cm – 5¾"	78.41.18	Ø 8 mm





C05

Knochenmühlen
Bone Mills
Molinos de hueso
Moulins à os
Mulini per ossa

BONE MILLS

Knochenmühle
Bone mill
Molino de hueso
Moulin à os
Mulino per ossa

mit Montageschlüssel
with assembling wrench
con llave de montaje
avec clé de montage
con chiave per montaggio



11 cm – 4³/₈" **68.82.75** Ø 68 mm

Knochenmühle
Bone mill
Molino de hueso
Moulin à os
Mulino per ossa

mit Titan-Mahlwerk
with titanium grinder
con trituradora de titanio
avec broyeur en titane
con fresa in titanio

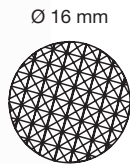

Ø 16 mm
16,5 cm – 6¹/₂"
68.82.76



Stellschraube für die Festlegung der Partikelgröße

Locking screw to determine size of bone particles

Tornillo de ajuste para la determinación del tamaño de las partículas

Vis de réglage pour définir la taille des particules

Vite di regolazione per definire la dimensione delle particelle



HAKIM FIBULA RASPATORY

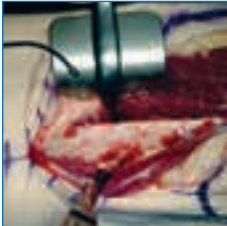

Mit dem gebogenen und als Kontrawinkel angepassten Ende des Raspatoriums kann die Fibula proximal und distal schonend umfahren werden. Die Abhalte-Vorrichtung funktioniert als Wundhaken zur Verdrängung des Musculus peroneus, der die Osteotomie-Stelle bedeckt.

The proximal and distal fibula can be gently circumnavigated thanks to a raspatory of which the end has been curved and adjusted to make a counter-angle. The holding device works as a retractor to push back the peroneus longus that covers the osteotomy site.

Con el extremo curvo y adaptado como contraángulo de la legra se puede rodear el peroné proximal y distal sin dañarlo. El dispositivo de separación funciona como separador para desplazar el músculo peroneal que cubre el lugar de la osteotomía.

L'extrémité courbée de la rugine, prenant la forme d'un contre-angle, permet de contourner la fibule de manière proximale et distale, sans l'abîmer. Le dispositif de serrage fonctionne comme un écarteur pour repousser le muscle fibulaire recouvrant la zone de l'ostéotomie.

Con l'estremità del periostotomo, ricurvo e adeguato come contrangolo, il perone può essere sottoposto a delicata dissezione prossimale e distale. La valva funziona da retrattore per il muscolo peroneo che copre il campo dell'osteotomia.

Fibula-Raspatorium
Fibula raspatory
Legra para fibula
Rugine pour fibule
Fibula periostotomo

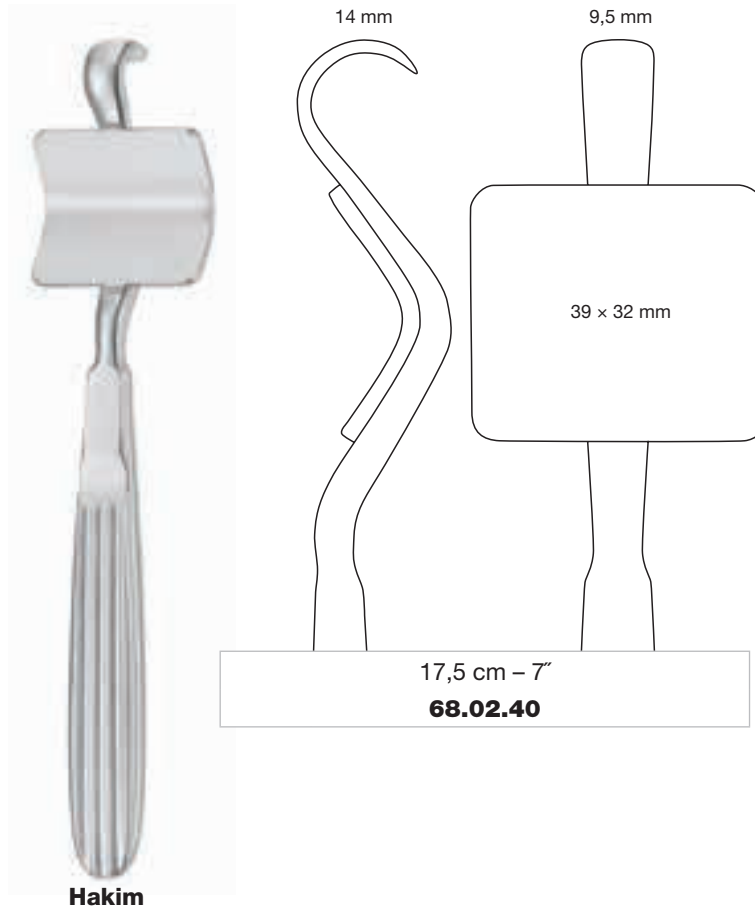

Hakim



C07

Instrumente für Frakturen des Collum mandibulae
Instruments for Mandibular Collum Fractures
Instrumentos para las fracturas en el cuello mandibular
Instrumentes pour les fractures du col mandibulaire
Strumenti per fratture del collum mandibulae

HAKIM COLLUM FRACTURE SET



- ▶ Ermöglicht intraoralen Zugang
- ▶ Wenig traumatisierend
- ▶ Keine Hauteinschnitte, minimale Verletzungsgefahr

- ▶ Permits an intraoral approach
- ▶ Minimal trauma
- ▶ No skin incision, minimal risk of injuries

- ▶ Permite el abordaje intraoral
- ▶ Trauma mínimo
- ▶ Ninguna incisión en la piel, riesgo minimal de lesiones

- ▶ Permet un accès intraoral
- ▶ Trauma minimal
- ▶ Pas d'incision de la peau, risque minimal de blessures

- ▶ Permette un accesso intraorale
- ▶ Poco traumatizzante
- ▶ Nessuna incisione, rischio ridotto di lesioni

Plattenhaltezange
 Plate holding forceps
 Pinza para agarrar placas
 Pince pour tenir les plaques
 Pinza da presa per placche

- ▶ ermöglicht gleichzeitig das Halten der Platte und das Einbringen der Schraube
- ▶ allows to hold the plate and simultaneously insert the screw
- ▶ permite sostener la placa y, al mismo tiempo, colocar el tornillo
- ▶ permet de retenir la plaque et de mettre la vis en place simultanément
- ▶ consente di trattenere la placca e nello stesso tempo di inserire la vite

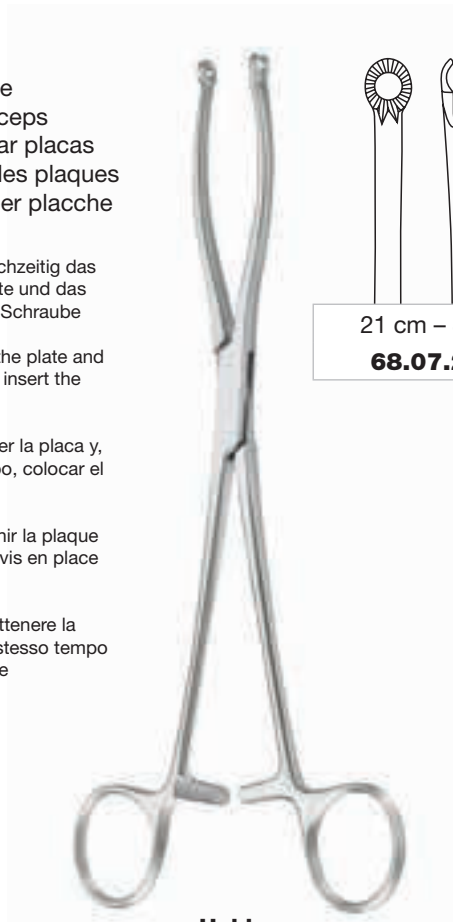

Hakim

21 cm – 8¼"
68.07.24

Titan-Collumplatte
 Titanium collum plate
 Placa collum de titanio
 Plaque collum en titane
 Placca collum in titanio

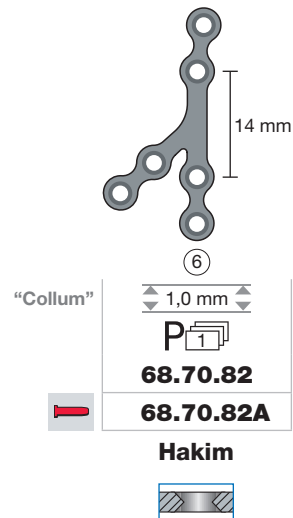

für links und rechts
 for left and right
 para izquierda y derecha
 pour gauche et droite
 per sinistra e destra

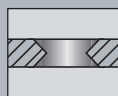

Löcher beidseitig gesenkt
 Holes countersunk on both sides
 Orificios avellanados de doble lado
 Trous fraisés des deux côtés
 Fori con incavo bilaterale



mit “TraceID”-Pin
 with “TraceID”-pin
 con pin “TraceID”
 avec insert “TraceID”
 con perno “TraceID”



HAKIM COLLUM FRACTURE SET



Intraoraler Retraktor mit Spiegel
 Intraoral retractor with mirror
 Separador intra oral con espejo
 Ecarteur intra-oral avec miroir
 Divaricatore intraorale con specchietto

- ▶ ermöglicht sehr gute Einsicht in den Frakturspalt und Kontrolle der Osteosynthese an der Hinterkante des Ramus mandibulae
- ▶ used to visually access the fracture gap and to check the osteosynthesis at the rear edge of the ramus mandibulae
- ▶ permite un muy buen examen en la hendidura de la fractura y un control de la osteosíntesis en el borde posterior de la rama mandibular
- ▶ permet un examen précis de la fente de la fracture et un contrôle de l'ostéosynthèse au niveau de l'arête arrière de la branche de la mandibule
- ▶ consente di avere un'ottima visuale della frattura e il controllo dell'osteosintesi sul bordo posteriore del ramo mandibolare

28 cm – 11"
68.07.15

Hakim



mit Kaltlichtbeleuchtung
 with fibre optic illumination
 con iluminación de luz fría
 avec illumination à lumière froide
 con illuminazione a luce fredda



C07

Instrumente für Frakturen des Collum mandibulae
Instruments for Mandibular Collum Fractures
Instrumentos para las fracturas en el cuello mandibular
Instruments pour les fractures du col mandibulaire
Strumenti per fratture del collum mandibulae

HAKIM COLLUM FRACTURE SET

Raspatorien
Raspatories
Legras
Rugines
Periostomi

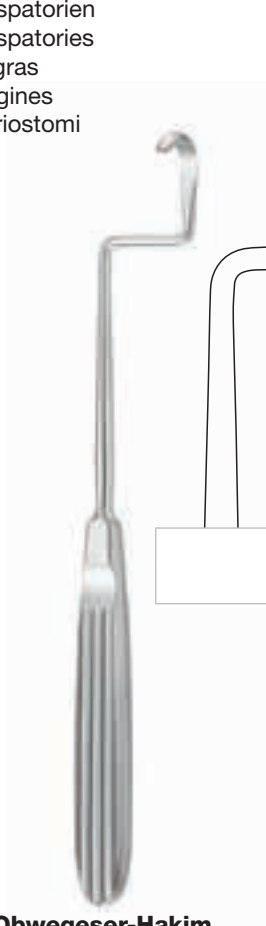

5 mm

20,5 cm – 8"
68.07.11



linke Seite
left side
lado izquierdo
côté gauche
lato sinistra

Obwegeser-Hakim



5 mm

20,5 cm – 8"
68.07.12



rechte Seite
right side
lado derecho
côté droit
lato destra

Obwegeser-Hakim

Adaptionsinstrument mit Kugel und Dorn
Applying instrument with ball and pin
Instrumento de adaptación con bola y perno
Instrument d'adaptation avec boule et épine
Strumento per adattamento con palla e punta



Hakim

19,5 cm – 7¾"

68.07.23



HAKIM COLLUM FRACTURE SET

Fasszange mit Sperre
 Grasping forceps with catch
 Pinza para agarrar con cremallera
 Pince à saisir avec crémaillère
 Pinza per afferrare con cremagliera

	
Ø 6 mm	a = 12 cm – 4¾"
	68.07.18

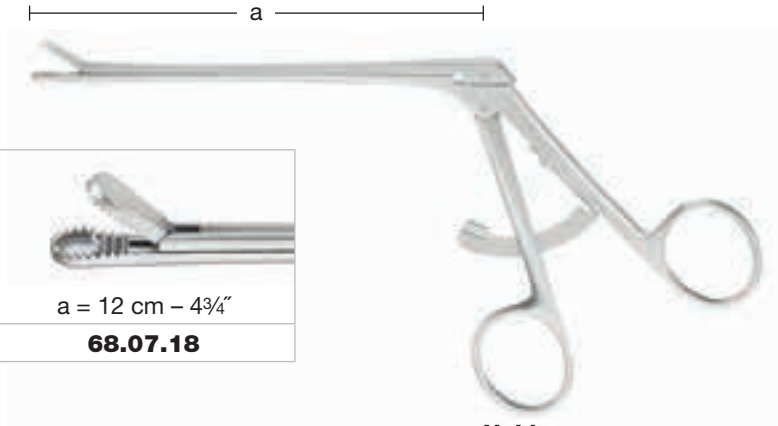

Hakim

Raspatorium
 Raspatory
 Legra
 Rugine
 Periostomo

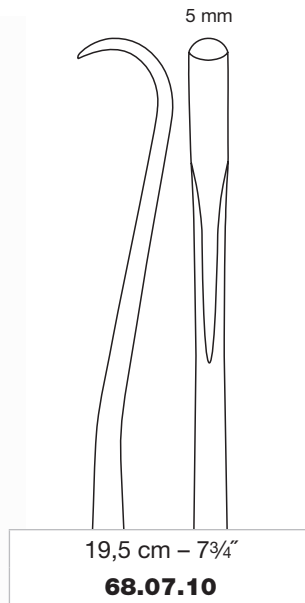

Obwegeser-Hakim

SURGICAL HAND PIECES

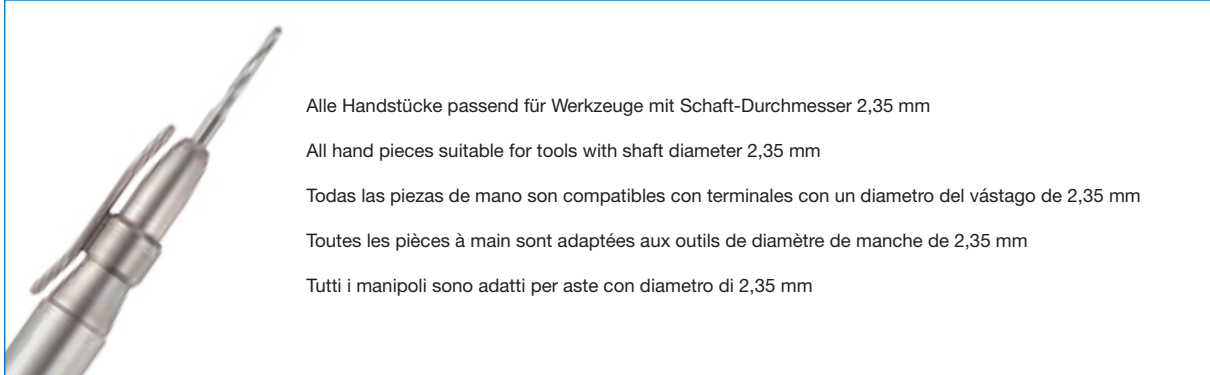

Alle Handstücke passend für Werkzeuge mit Schaft-Durchmesser 2,35 mm
 All hand pieces suitable for tools with shaft diameter 2,35 mm
 Todas las piezas de mano son compatibles con terminales con un diametro del vástago de 2,35 mm
 Toutes les pièces à main sont adaptées aux outils de diamètre de manche de 2,35 mm
 Tutti i manipoli sono adatti per aste con diametro di 2,35 mm

Chirurgische Handstücke für Motorensysteme
Surgical hand pieces for motor systems
Piezas de mano quirúrgica para sistemas de motor
Pièces à main chirurgical pour systèmes de moteur
Manipoli chirurgici per sistemi motori

- ▶ mit Farbmarkierung für Übersetzungsverhältnis
- ▶ mit Drehring-Spannzange
- ▶ mit Spülrohr

- ▶ with color coding for gear transmission ratio
- ▶ with swivel chuck
- ▶ with irrigation tube

- ▶ con relación de transmisión identificada por colores
- ▶ con cierre de anillo
- ▶ con tubo de irrigación

- ▶ avec marquage de couleur indiquant le rapport de transmission
- ▶ avec serrage à rotation
- ▶ avec canule de lavage

- ▶ con codice colore per rapporto di trasmissione
- ▶ con chiusura ad anello girevole
- ▶ con tubo di lavaggio



8,5 cm – 3 3/8" **63.45.07** 1:1



9 cm – 3 1/2" **63.45.44** 1:1



9 cm – 3 1/2" **63.45.48** 30:1



SURGICAL HAND PIECES

Chirurgische Handstücke für Motorensysteme
 Surgical hand pieces for motor systems
 Piezas de mano quirúrgica para sistemas de motor
 Pièces à main chirurgicale pour systèmes de moteur
 Manipoli chirurgici per sistemi motori

- ▶ mit Farbmarkierung für Übersetzungsverhältnis
- ▶ mit Drehring-Spannzange
- ▶ mit Spülrohr
- ▶ with color coding for gear transmission ratio
- ▶ with swivel chuck
- ▶ with irrigation tube

- ▶ con relación de transmisión identificada por colores
- ▶ con cierre de anillo
- ▶ con tubo de irrigación

- ▶ avec marquage de couleur indiquant le rapport de transmission
- ▶ avec serrage à rotation
- ▶ avec canule de lavage

- ▶ con codice colore per rapporto di trasmissione
- ▶ con chiusura ad anello girevole
- ▶ con tubo di lavaggio



11 cm – 4³/₈" **63.45.11** 1:1



13 cm – 5¹/₈" **63.45.13** 1:1



16 cm – 6¹/₄" **63.45.15** 1:1



Fräser
 Burrs
 Fresas
 Fraises
 Frese

mit Schaft-Durchmesser 2,35 mm
 with shaft diameter 2,35 mm
 con un diametro del vástago de 2,35 mm
 avec diamètre de manche de 2,35 mm
 con asta da 2,35 mm di diametro

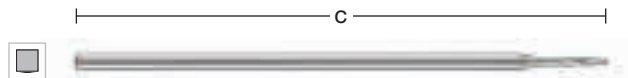

Lindemann

c = 75,0 mm	68.61.01	Ø 2,0 mm
c = 65,0 mm	68.61.02	Ø 2,0 mm
c = 45,0 mm	68.61.03	Ø 2,0 mm
c = 44,5 mm	68.61.05	Ø 1,4 mm
c = 70,0 mm	68.61.06	Ø 1,4 mm



ANGULAR SCREWDRIVERS



Winkelschraubendreher für Plattenosteosynthesen in schwer zugänglichen Regionen des Unterkiefers und Mittelgesichtes anstelle einer transbukkalen/transfacialen Weichteilperforation direkt über den intraoralen, supra/infraorbitalen oder coronalen Zugang zur Fraktur.

Angular screwdriver for plate osteosynthesis in difficult-to-reach regions of the mandible and mid-face instead of a transbuccal/transfacial softtissue perforation directly through the intraoral supra-/infraorbital or coronal approach to a fracture.

Destornillador de ángulo para osteosíntesis de placas en regiones difíciles de la mandíbula y del tercio medio, en vez de una perforación de las partes blandas transbuccales y transfaciales directamente encima del acceso infraorbital o coronal a la fractura.

Tournevis angulaire pour des ostéosynthèses à plaques dans des régions d'un abord difficile au niveau de la mâchoire inférieure et du milieu du visage, au lieu d'une perforation transbuccale/transfaciale des parties molles directement sur l'accès intraoral, supra-/infraorbital ou coronal de la fracture.

Cacciavite angolato per placche di osteosintesi in zone di difficile accesso della regione mascellare e mediofaciale, in sostituzione della perforazione transbuccale e transfaciale di parti molli, accedendo alla frattura direttamente in modo intraorale, orbitale o coronale.

Winkelschraubendreher für Handantrieb oder Mikromotor
 Angular screwdrivers for hand drive or micro motor
 Destornilladores de ángulo para uso manual o con micromotor
 Tournevis angulaire avec commande manuelle ou micromoteur
 Cacciaviti angolati per l'utilizzo manuale o con il micromotore

INTRA



19 cm – 7½"	68.30.01		13:1
19 cm – 7½"	68.30.10		6,5:1

Handantrieb für Winkelschraubendreher
 Manual drive for angular screwdriver
 Impulso manual para destornillador de ángulo
 Manivelle pour tournevis angulaire
 Manico d'azionamento per cacciavite angolato

mit rotierendem Endstück
 with freely roating end piece
 con pieza final giratoria
 avec bout rotatif indépendant
 con pezzo finale a rotazione libera

360°



INTRA

12 cm – 4¾"	68.30.05
-------------	-----------------

INTRA
 Kupplung nach DIN 13940-1 (ISO 3964)
 Coupling acc. to DIN 13940-1 (ISO 3964)
 Acoplamiento según DIN 13940-1 (ISO 3964)
 Selon la norme DIN 13940-1 (ISO 3964)
 Attacco secondo DIN 13940-1 (ISO 3964)

Übersetzungsverhältnis
 Gear transmission
 Relación de transmisión
 Rapport de transmission
 Rapporto di trasmissione



ANGULAR SCREWDRIVERS

Schraubenhaltevorrichtung für Winkelschraubendreher
 Screw holding device for angular screwdriver
 Dispositivo para tornillos para destornillador de ángulo
 Dispositif de vis pour tournevis angulaire
 Dispositivo portaviti per cacciavite angolato



15,5 cm – 6 1/8"				
68.30.06				
bestehend aus: consisting of: compuesto por: composé de: composto da:	<table border="0"> <tr> <td style="text-align: center;">68.30.07</td> <td> Klemmbacken Fixation clamps Mordazas Clips pour le dispositif de vis Clip di fissazione </td> <td style="text-align: right; vertical-align: bottom;">2x</td> </tr> </table>	68.30.07	Klemmbacken Fixation clamps Mordazas Clips pour le dispositif de vis Clip di fissazione	2x
	68.30.07	Klemmbacken Fixation clamps Mordazas Clips pour le dispositif de vis Clip di fissazione	2x	
	<table border="0"> <tr> <td style="text-align: center;">68.30.08</td> <td> Haltefeder Retaining spring Resorte para dispositivo Ressort pour le dispositif de vis Molla per dispositivo </td> <td style="text-align: right; vertical-align: bottom;">1x</td> </tr> </table>	68.30.08	Haltefeder Retaining spring Resorte para dispositivo Ressort pour le dispositif de vis Molla per dispositivo	1x
68.30.08	Haltefeder Retaining spring Resorte para dispositivo Ressort pour le dispositif de vis Molla per dispositivo	1x		
<table border="0"> <tr> <td style="text-align: center;"></td> <td> Schraubendreher zur Montage Screwdriver for mounting purposes Destornillador para el ensamblaje Tournevis pour le montage Giravite per montaggio </td> <td style="text-align: right; vertical-align: bottom;">1x</td> </tr> </table>		Schraubendreher zur Montage Screwdriver for mounting purposes Destornillador para el ensamblaje Tournevis pour le montage Giravite per montaggio	1x	
	Schraubendreher zur Montage Screwdriver for mounting purposes Destornillador para el ensamblaje Tournevis pour le montage Giravite per montaggio	1x		

Vorbohrer-Einsätze
 Drill inserts
 Insertos para brocas
 Embouts perforateurs
 Perforatori per cacciavite angolati

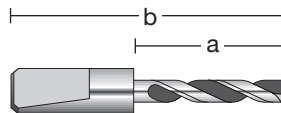

2:1

1.5	a = 6 mm	b = 14 mm	68.30.19	Ø 1,2 mm
2.0	a = 6 mm	b = 14 mm	68.30.20	Ø 1,5 mm
2.0	a = 18 mm	b = 21 mm	68.30.18	Ø 1,6 mm
2.4	a = 6 mm	b = 10 mm	68.30.21	Ø 1,7 mm



C09

Einsätze für Winkelschraubendreher
Inserts for Angular Screwdriver
Insertos para destornillador de ángulo
Embouts pour le tournevis angulaire
Inserti per cacciavite angolato

ANGULAR SCREWDRIVERS

Schraub-Einsätze
 Screwing inserts
 Insertos para destornillador
 Embouts pour le tournevis
 Inserti per cacciavite

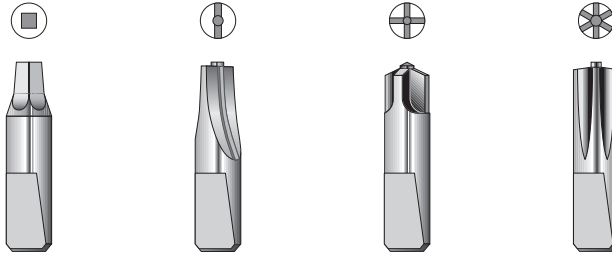

2:1

1.5 MICRO

68.30.38	68.30.36	68.30.51	68.30.50
-----------------	-----------------	-----------------	-----------------

2.0 MINI

68.30.37	68.30.34	68.30.53	68.30.52
-----------------	-----------------	-----------------	-----------------

2.4 MANDIBULAR

		68.30.49	68.30.48
--	--	-----------------	-----------------

Schraub-Einsatz für Kondylen
 Screwing insert for condylar implants
 Inserto para destornillador para cóndilos
 Embout pour le tournevis pour condyles
 Inserto cacciavite per condili



2:1

68.30.39

Mikro-Sägen mit Silikon Griff
Micro Saws with Silicone Handle
Micro sierras con mango de silicona
Micro scies avec poignée en silicone
Micro seghe con impugnatura in silicone

C10



Für bessere Griffsicherheit in trockener und feuchter Umgebung
For a better grip in dry and humid conditions
Para un apoyo mejorado en ambientes secos y húmedos
Pour une meilleure maniabilité dans un milieu sec ou humide
Per una presa migliore in un ambiente secco ed umido



C10

Mikro-Sägen (ohne Sägeblätter)
Micro Saws (without Saw Blades)
Micro sierras (sin hojas de sierra)
Micro scies (sans lames de scie)
Micro seghe (senza lame da sega)

MICRO SAWS

Oszillierende Mikro-Säge mit Schlüssel
 Micro oscillating saw with wrench
 Micro sierra oscilante con llave
 Micro scie oscillante avec clé
 Micro sega oscillante con chiave



Spülrohr, integriert
 Irrigation tube, integrated
 Tubo de irrigación, integrado
 Canule de lavage, intégrée
 Tubo di lavaggio, integrato

Sachse

12,5 cm - 5"	68.24.00		15.000 U/min
12,5 cm - 5"	68.24.01		15.000 U/min

Sägeblätter
 Saw blades
 Hojas de sierra
 Lames de scie
 Lame da sega

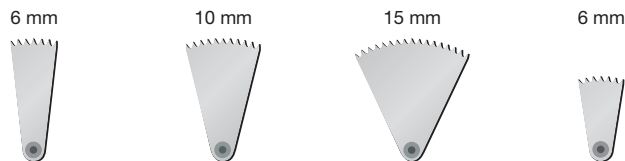

1:1

a = 16 mm	a = 16 mm	a = 16 mm	a = 16 mm
68.24.24	68.24.25	68.24.26	68.24.30

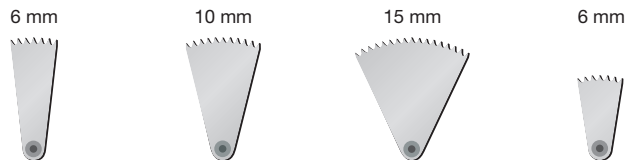

1:1

a = 30 mm	a = 30 mm	a = 30 mm	a = 30 mm
68.24.27	68.24.28	68.24.29	68.24.31

Überwurfmutter für Spannfutter (allein)
 Fixation nut for chuck (only)
 Tuerca de racor para mandril de sujeción (sola)
 Ecrou fileté pour mandrin de serrage (seule)
 Dado per raccordi per mandrino (solo)



68.24.19

Zubehör
 Accessories
 Accesorios
 Accessori

Schlüssel (allein)
 Wrench (only)
 Llave (sola)
 Clé (seule)
 Chiave (sola)



68.24.20



Maximale Motordrehzahl = Oszillationen/Minute
 Maximum speed = oscillations/minute
 Revoluciones máximas del motor = oscilaciones/minute
 Nombre de tours maximum = oscillations/minute
 Massimo numero di giri del motore = oscillazioni/minute



Verpackungseinheit "X" Stück
 Packing unit "X" pieces
 Paquete de "X" unidades
 Emballage de "X" pièces
 Confezione da "X" pezzi

MICRO SAWS

Mikro-Sagittal-Säge mit Schlüssel
 Micro sagittal saw with wrench
 Micro sierra sagital con llave
 Micro scie sagittale avec clé
 Micro sega sagittale con chiave



Spülrohr, integriert
 Irrigation tube, integrated
 Tubo de irrigación, integrado
 Canule de lavage, intégrée
 Tubo di lavaggio, integrato

Sachse

12,5 cm – 5"	68.24.02		20.000 U/min
12,5 cm – 5"	68.24.03		20.000 U/min

Sägeblätter
 Saw blades
 Hojas de sierra
 Lames de scie
 Lame da sega

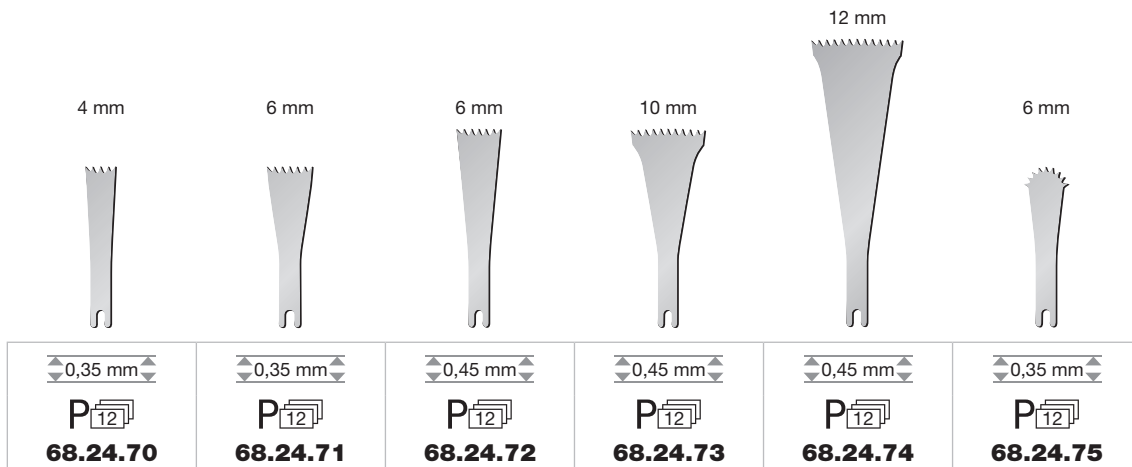

1:1

Überwurfmutter für Spannfutter (allein)
 Fixation nut for chuck (only)
 Tuerca de racor para mandril de sujeción (sola)
 Ecrou fileté pour mandrin de serrage (seule)
 Dado per raccordi per mandrino (solo)

68.24.19

Zubehör
 Accessories
 Accesorios
 Accessoires
 Accessori

Schlüssel (allein)
 Wrench (only)
 Llave (sola)
 Clé (seule)
 Chiave (solo)

68.24.20



Kunststoffgriff (autoklavierbar bis 134 °C bei 3 bar)
 Plastic handle (autoclavable up to 134 °C at 3 bar)
 Mango de plástico (autoclavable hasta 134 °C bajo presión de 3 bar)
 Manche en plastique (autoclavable à 134 °C sous pression de 3 bars)
 Manico di plastica (autoclavabile fino a 134 °C sotto pressione di 3 bar)

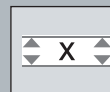

Blattstärke
 Thickness of blade
 Grosor de la hoja
 Epaisseur de la lame
 Spessore della lama



C10

Mikro-Sägen (ohne Sägeblätter)
Micro Saws (without Saw Blades)
Micro sierras (sin hojas de sierra)
Micro scies (sans lames de scie)
Micro seghe (senza lame da sega)

MICRO SAWS

Osseoskalpell mit Schlüssel
 Osseoscalpel with wrench
 Osseoscalpel con llave
 Osséoscalpel avec clé
 Osseoscalpello con chiave

US Pat. 5,201,749 / DE 40 29 676



Spülrohr, integriert
 Irrigation tube, integrated
 Tubo de irrigación, integrado
 Canule de lavage, intégrée
 Tubo di lavaggio, integrato

Sachse

12,5 cm - 5"	68.24.05		20.000 U/min
12,5 cm - 5"	68.24.06		20.000 U/min



Mikro-Säge mit axial/sagittalem Schnitt, Pendelhub, besonders geeignet für dreidimensionale Schnittführungen
 Micro saw with axial/sagittal cut, oscillating hub, especially suitable for three dimensional cutting
 Micro sierra con corte axial/sagital, elevacion de pendulo, especialmente apropiada para cortes tridimensionales
 Micro scie à coupe axiale/sagittale, par voie excentrique, particulièrement conçue pour des coupes tridimensionnelles
 Micro sega con taglio assiale/saggitale, corsa del pendolo, adatto particolarmente per guida di tagli tredimensionali

Sägeblätter
 Saw blades
 Hojas de sierra
 Lames de scie
 Lame da sega

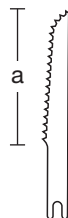

1:1

$\Delta 0,35 \text{ mm}$ P₁₂ a = 12 mm 68.24.35	$\Delta 0,35 \text{ mm}$ P₁₂ a = 18 mm 68.24.36	$\Delta 0,35 \text{ mm}$ P₁₂ a = 24 mm 68.24.37
---	---	---

Überwurfmutter für Spannfutter (allein)
 Fixation nut for chuck (only)
 Tuerca de racor para mandril de sujeción (sola)
 Ecrou fileté pour mandrin de serrage (seule)
 Dado per raccordi per mandrino (solo)



68.24.19

Zubehör
 Accessories
 Accesorios
 Accessoires
 Accessori

Schlüssel (allein)
 Wrench (only)
 Llave (sola)
 Clé (seule)
 Chiave (sola)



68.24.20



Maximale Motordrehzahl = Oszillationen/Minute
 Maximum speed = oscillations/minute
 Revoluciones máximas del motor = oscilaciones/minuto
 Nombre de tours maximum = oscillations/minute
 Massimo numero di giri del motore = oscillazioni/minuto

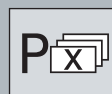

Verpackungseinheit "X" Stück
 Packing unit "X" pieces
 Paquete de "X" unidades
 Emballage de "X" pièces
 Confezione da "X" pezzi

MICRO SAWS

Mikro-Stichsäge mit Schlüssel
 Micro compass saw with wrench
 Micro sierra de vaivén con llave
 Micro scie à guichet avec clé
 Micro sega con chiave

Spülrohr, abnehmbar
 Irrigation tube, detachable
 Tubo de irrigación, desmontable
 Canule de lavage, démontable
 Tubo di lavaggio, smontabile



Sachse			
12,5 cm – 5"	68.24.10		15.000 U/min
12,5 cm – 5"	68.24.11		15.000 U/min

68.24.22

Spülrohr (allein)
 Irrigation tube (only)
 Tubo de irrigación (sola)
 Canule de lavage (seule)
 Tubo di lavaggio (sola)

Hartmetall-Raspelaufsatz
 Tungsten carbide rasp
 Escofina de carburo de tungsteno
 Râpe en carbure de tungstène
 Raspa in carburo di tungsteno



"HM"
 5,5 cm – 2 1/8"
68.24.21

Sägeblätter
 Saw blades
 Hojas de sierra
 Lames de scie
 Lame da sega

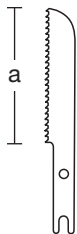

0,25 mm	0,25 mm	0,25 mm	0,25 mm	0,25 mm
P₁₂	P₁₂	P₁₂	P₁₂	P₁₂
a = 11 mm	a = 14 mm	a = 18 mm	a = 22 mm	a = 26 mm
68.24.12	68.24.13	68.24.14	68.24.15	68.24.16

1:1

Überwurfmutter für Spannfutter (allein)
 Fixation nut for chuck (only)
 Tuerca de racor para mandril de sujeción (sola)
 Ecrou fileté pour mandrin de serrage (seule)
 Dado per raccordi per mandrino (solo)

68.24.19

Zubehör
 Accessories
 Accesorios
 Accessoires
 Accessori

Schlüssel (allein)
 Wrench (only)
 Llave (sola)
 Clé (seule)
 Chiave (sola)

68.24.20



Kunststoffgriff (autoklavierbar bis 134 °C bei 3 bar)
 Plastic handle (autoclavable up to 134 °C at 3 bar)
 Mango de plástico (autoclavable hasta 134 °C bajo presión de 3 bar)
 Manche en plastique (autoclavable à 134 °C sous pression de 3 bars)
 Manico di plastica (autoclavabile fino a 134 °C sotto pressione di 3 bar)



Blattstärke
 Thickness of blade
 Grosor de la hoja
 Epaisseur de la lame
 Spessore della lama



C10

Mikro-Sägen
Micro Saws
Micro sierras
Micro scies
Micro seghe

MICRO SAWS

Indikationsbereiche
 Fields of applications
 Campos de indicación
 Secteurs d'application
 Campi di applicazione



68.24.00	68.24.02	68.24.05	68.24.10
68.24.01	68.24.03	68.24.06	68.24.11

Kraniofaziale Chirurgie Craniofacial Surgery Chirurgia craneofacial Chirurgie crano-faciale Chirurgia craniofacciale	Entnahme von Kalotten-Transplantaten Harvesting of cranial bone grafts Extracción de trasplantes de calota Prélèvement de transplants de la calotte Prelievo di innesti della calotta	○	☆	★	☆
	Osteotomie des Frontal Bandeau einschließlich Orbitotomie Osteotomy of the frontal bandeau including orbitotomy Osteotomía de la banda frontal incluido orbitotomía Ostéotomie du bandeau frontal avec orbitotomie Osteotomia della fascia frontale incluso orbitotomia	○	☆	★	☆
	Osteotomie und Konturierung der Kalottensegmente Osteotomy and contouring of cranial segments Osteotomía y contorneado de los segmentos de la calota Ostéotomie et contours des segments de la calotte Osteotomia e contornitura dei segmenti di calotta	☆	★	☆	○
	Osteotomie im Nasoethmoidalkomplex Osteotomy within the nasal ethmoidal complex Osteotomía en el complejo nasoethmoidal Ostéotomie dans le complexe nasoéthmoidal Osteotomia nel complesso nasoetmoidale	—	☆	☆	☆

Maxillofaziale Chirurgie Maxillofacial Surgery Cirugía maxilofacial Chirurgie maxillo-faciale Chirurgia maxillofacciale	Inderdentale Osteotomie Interdental osteotomy Osteotomía interdental Ostéotomie interdental Osteotomia interdental	☆	☆	☆	☆
	Transversale Orbitotomie Transversal orbitotomy Orbitotomía transversal Orbitotomie transversale Orbitotomia trasversale	★	○	○	○
	Osteotomie der fazialen Unterkieferwand nach Abello oder Lindorf Osteotomy of the facial mandibular wall acc. to Abello or Lindorf Osteotomía de la pared mandibular facial según Abello o Lindorf Ostéotomie de la paroi du maxillaire inférieure faciale selon Abello ou Lindorf Osteotomia della parete mandibolare facciale secondo Abello o Lindorf	★	☆	☆	☆
	Vertikale Osteotomie des aufsteigenden Unterkiefers von intraoral Vertical osteotomies of the ascending ramus from intraoral Osteotomías verticales del maxilar inferior ascendente desde intraoral Ostéotomies verticales du maxillaire inférieur montant, en intra-oral Osteotomie verticali della mandibola ascendente intraorali	★	—	—	—
	Laterale Segmentosteotomien Lateral segment osteotomies Osteotomías de segmentos laterales Ostéotomies des segments latéraux Osteotomie di segmenti laterali	★	☆	☆	☆
	Anteriore Segmentosteotomien Anterior segment osteotomies Osteotomías de segmentos anteriores Ostéotomies des segments antérieurs Osteotomie di segmenti anteriori	☆	☆	★	★



sehr gut geeignet
 absolutely suitable
 especialmente apto
 très approprié
 perfettamente appropriato



gut geeignet
 very suitable
 muy apto
 bien approprié
 molto appropriato



geeignet
 suitable
 apropiado
 approprié
 appropriato

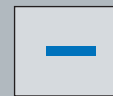

ungeeignet
 not suitable
 no apto
 non approprié
 non appropriato



MICRO SAWS

Indikationsbereiche
Fields of applications
Campos de indicación
Secteurs d'application
Campi di applicazione



		68.24.00	68.24.02	68.24.05	68.24.10
		68.24.01	68.24.03	68.24.06	68.24.11
Maxillofaziale Chirurgie Maxillofacial Surgery Chirurgia maxillo-facial Chirurgia maxillo-facciale	Osteotomien der Le Fort Ebenen Le Fort osteotomies Osteotomías de los planos de Le Fort Ostéotomies des plans de Le Fort Osteotomie dei piani di Le Fort	—	☆	☆	☆
	Osteotomien des Unterkiefers inklusive sagittale Spaltung Mandibular osteotomies incl. sagittal split Osteotomías del maxilar inferior inclusive escisión sagital Ostéotomies du maxillaire inférieur avec fission sagittale Osteotomie della mandibola compreso l'osteotomia saggitale	—	○	★	○
	Kinnosteotomien Chin osteotomies Osteotomías de mentón Ostéotomies du menton Osteotomie del mento	○	○	★	☆
	Tumorresektionstherapie Tumor resection therapy Terapia de resección de tumores Thérapie par résection tumorale Terapia di resezione dei tumori	○	☆	★	☆
	Osteotomie der Scapula, des Beckenkammes und der Fibula im Rahmen der Rekonstruktionstherapie				
	Osteotomy of scapula, iliac crest and fibula within reconstruction therapy				
	Osteotomía de los omóplatos de la cresta iliaca del peroné en el marco de la terapia reconstructiva	○	☆	☆	☆
Ostéotomie de l'omoplate, du bassin et du péroné, dans le cadre de la thérapie reconstructive					
Osteotomia della scapola, della cresta iliaca e del perone nell'ambito della terapia ricostruttiva					

sehr gut geeignet
absolutely suitable
especialmente apto
très approprié
perfettamente appropriato

gut geeignet
very suitable
muy apto
bien approprié
molto appropriato

geeignet
suitable
apropiado
approprié
appropriato

ungeeignet
not suitable
no apto
non approprié
non appropriato



Weitere Produkte für die Mund-, Kiefer- und Gesichtschirurgie
Further Products for Maxillofacial Surgery
Más productos para la cirugía maxilofacial
D'autres produits pour la chirurgie maxillo-faciale
Ulteriori prodotti per la chirurgia maxillo-facciale

Enorale Distraktoren für Ober- und Unterkiefer
Intraoral distraction devices for upper and lower jaw
Distractores intraorales para la mandíbula inferior y superior
Distracteurs intra-oraux pour mâchoire inférieure et supérieure
Distrattori intraorali per la mascella superiore e della mandibola

451.08.13



DISTRACTION DEVICES

Transantrale Oberkieferdistraktoren
 Transantral maxilla distraction devices
 Distractores transantrales para el maxilar superior
 Distracteurs transantraux pour mâchoire supérieure
 Distrattori transantrali per la mascella superiore



Unterkieferdistraktor für den Alveolarkammaufbau
 Mandibular distraction device for alveolar bone reconstruction
 Distractor mandibular para la reconstrucción de la cresta alveolar
 Distracteur mandibulaire pour la reconstitution de la crête alvéolaire
 Distrattore mandibolare per la ricostruzione della cresta alveolare

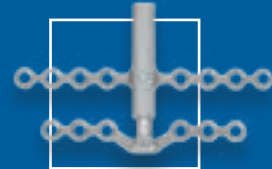

Horizontale Unterkieferdistraktoren
 Horizontal mandibular distraction devices
 Distractores horizontales para la mandíbula inferior
 Distracteurs mandibulaires horizontals
 Distrattori mandibolari orizzontali

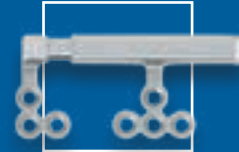

Vertikale Unterkieferdistraktoren
 Vertical mandibular distraction devices
 Distractores verticales para la mandíbula inferior
 Distracteurs mandibulaires verticals
 Distrattori mandibolari verticali

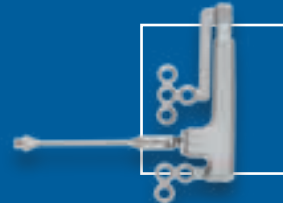

Medianer Unterkieferdistraktor
 Median mandibular distraction device
 Distractor mediano para la mandíbula inferior
 Distracteur mandibulaire médian
 Distrattore mandibolare mediano



Parallele Unterkieferdistraktoren
 Parallel mandibular distraction devices
 Distractores paralelos para la mandíbula inferior
 Distracteurs mandibulaires parallèles
 Distrattori mandibolari paralleli



Weitere Produkte für die Mund-, Kiefer- und Gesichtschirurgie
Further Products for Maxillofacial Surgery
Más productos para la cirugía maxilofacial
D'autres produits pour la chirurgie maxillo-faciale
Ulteriori prodotti per la chirurgia maxillo-facciale

Aarhus-Ankerschrauben, selbstbohrend
Aarhus anchorage screws, self-drilling
Aarhus tornillos de anclaje, auto-perforantes
Aarhus vis à ancre, auto-perforantes
Aarhus viti ad ancora, auto-perforanti

AARHUS MINI-IMPLANT

451.09.34

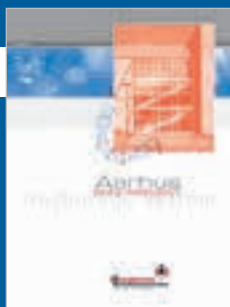

Das "Aarhus Mini-Implant"-System dient der kieferorthopädischen Therapie (Verankerung kieferorthopädischer Apparaturen mit Drähten, Zugfedern, Gummiringen) zur Behebung von Zahn- und Gebissfehlstellungen.

The "Aarhus Mini-Implant" system is designed for orthodontic treatment (anchorage of orthodontic appliances with wires, springs, rubber rings) for correction of incorrectly positioned teeth and jaws.

El sistema "Aarhus Mini-Implant" sirve para corregir las posiciones erróneas de los dientes y la dentadura mediante la terapia ortodóntica (anclaje de ortodoncias con alambres, resortes de tracción, aros de goma).

Le système des "Aarhus Mini-Implant" est utilisé dans le traitement orthodontique des malpositions dentaires et des mal occlusions (ancrage d'appareils orthodontiques avec fils, ressorts de traction et anneaux caoutchouc).

Il sistema di "Aarhus Mini-Implant" serve per la terapia ortodontica (ancoraggio di apparecchi ordodontici con fili, molle di trazione, anelli in gomma) nel trattamento di disallineamenti dentali e malocclusioni.



Implantate für die knochenverankerte Gaumennahterweiterung
Implants for bone-anchored palatal expansion
Implantes para la expansión palatina con anclaje óseo
Implants pour l'expansion palatine par ancrage osseux
Impianti per l'espansione del palato con ancoraggio osseo

RAPID PALATAL EXPANSION

450.03.41



Das "Å-RPE"-Verankerungssystem dient der knochenverankerten, schnellen Gaumennahterweiterung in Kombination mit einer GNE-Dehnschraube (Fremdprodukt) zur Behebung von Oberkieferengständen.

The "Å-RPE" anchoring system is used for bone-anchored, rapid palatal expansion in combination with a RPE expansion screw (third-party product) for correction of a narrow upper jaw.

El sistema de anclaje "Å-RPE" se utiliza en la expansión rápida de anclaje óseo de la sutura palatina en combinación con un tornillo de expansión RPE (producto de otro fabricante), para eliminar apiñamientos en el maxilar superior.

Le système d'ancrage "Å-RPE" sert à l'expansion palatine rapide par ancrage osseux et est utilisé en liaison avec une vis d'extension EPR (produit tiers) destinée à réparer les chevauchements dentaires au niveau de la mâchoire supérieure.

Il sistema di ancoraggio "Å-RPE" serve all'espansione rapida del palato con ancoraggio osseo in combinazione con vite per REP (di un altro produttore) per l'eliminazione di affollamenti dell'arcata superiore.





Weitere Produkte für die Mund-, Kiefer- und Gesichtschirurgie
Further Products for Maxillofacial Surgery
Más productos para la cirugía maxilofacial
D'autres produits pour la chirurgie maxillo-faciale
Ulteriori prodotti per la chirurgia maxillo-facciale

Titanplatten für die chirurgisch-epithetische Versorgung
Titanium plates for surgical-prosthetic treatment
Placas de titanio para el tratamiento general quirúrgico-epitético
Plaques en titane pour la procédure chirurgicale-prothétique
Placche in titanio per un trattamento chirurgico ed epitetico

EPIPLATING

451.09.21



Das "Epiplating"-System ist für die Anwendung bei Eingriffen an den knöchernen Strukturen des Schädels bestimmt. Es dient zur Knochenverankerung von Epithesen und Hörgeräten.

The "Epiplating" System is intended for use in surgical interventions on the osseous structures of the skull for osseo-integrated bone anchorage of craniofacial prosthesis and bone conduction hearing systems.

El sistema "Epiplating" es adecuado para las intervenciones en la estructura ósea del cráneo. Sirve para la fijación ósea de epítesis y prótesis acústicas.

Le système "Epiplating" convient pour des utilisations lors d'interventions sur les structures osseuses du crâne. Celui-ci sert à l'ancrage osseux d'épithèses et d'appareils auditifs.

Il sistema "Epiplating" è destinato all'uso negli interventi sulle strutture ossee del cranio. Serve all'ancoraggio osseo di epitesi e di apparecchi acustici.

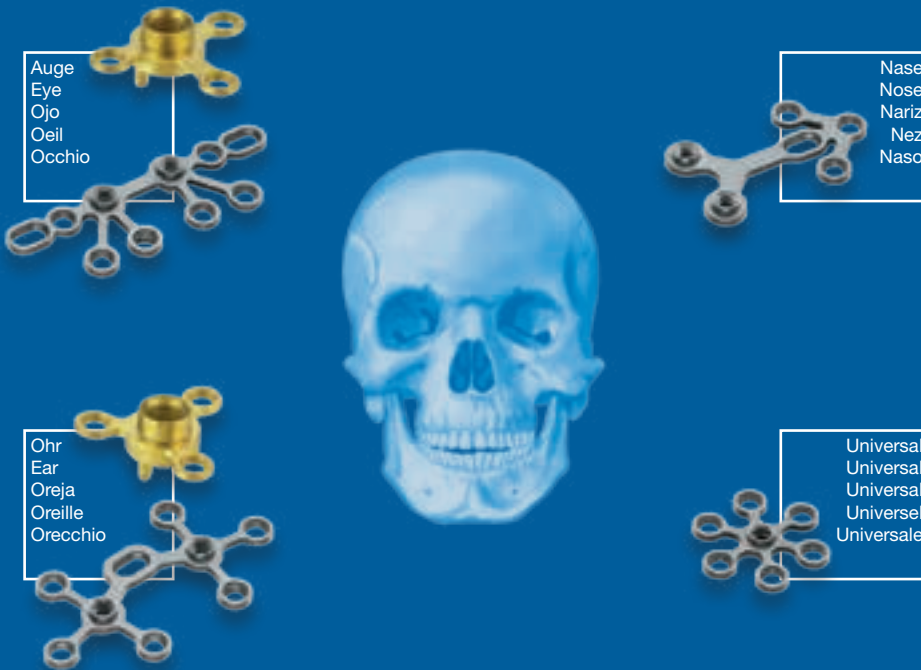

Weitere Produkte für die Mund-, Kiefer- und Gesichtschirurgie
Further Products for Maxillofacial Surgery
Más productos para la cirugía maxilofacial
D'autres produits pour la chirurgie maxillo-faciale
Ulteriori prodotti per la chirurgia maxillo-facciale

OP-Technik und Instrumentarium
Surgical technique and instrumentation
Técnica quirúrgica e instrumentos
Technique opératoire et instruments
Tecnica operatoria e strumentario

451.09.02



BIMAXILLARY SURGERY

Dieser Prospekt zeigt Schritt für Schritt eine bimaxilläre Operation mit dem in Folge verwendeten Instrumentarium.

This brochure shows "step by step" a bimaxillary surgery as well as the sequence of instruments used.

En el folleto actual presentamos paso por paso una cirugía bimaxilar junto con los instrumentos que se usan en secuencia.

Cette brochure montre pas à pas une opération bimaxillaire et les instruments employés dans l'ordre d'utilisation.

Questo depliant fa vedere passo per passo un intervento bimaxillare e lo strumentario usato.



Implantate für die Osteosynthese
Implants for the osteosynthesis
Implantes para la osteosintesis
Implants pour l'ostéosynthèse
Impianti per la osteosintesi

450.00.61



MEDICON IMPLANT ART OSTEOSYNTHESIS

Der Katalog umfasst die Systeme: CMS 1.2, MICRO 1.5, MINI 2.0 und Mandibular 2.4 mit den jeweiligen Implantaten sowie dem dazugehörigen Instrumentarium.

The catalog comprises the CMS 1.2, MICRO 1.5, MINI 2.0 and MANDIBULAR 2.4 systems together with their implants and instruments.

El catálogo comprende los siguientes sistemas: CMS 1.2, MICRO 1.5, MINI 2.0 y MANDIBULAR 2.4 con los implantes correspondientes así como con el respectivo instrumental.

Le catalogue regroupe les systèmes suivants: CMS 1.2, MICRO 1.5, MINI 2.0 et MANDIBULAR 2.4 avec les implants ainsi que les instruments correspondants.

Il catalogo comprende i seguenti sistemi CMS 1.2, MICRO 1.5, MINI 2.0 e MANDIBULAR 2.4 con le rispettive impianti e il corrispondente strumentario.

MEDICON

instruments

OMF - SURGERY

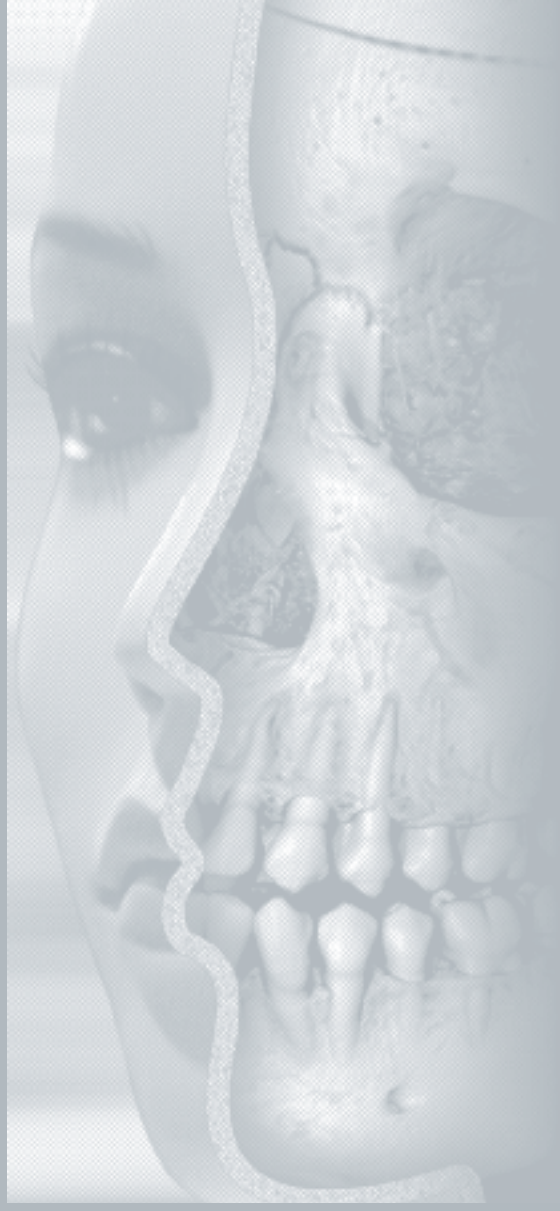



Empty rectangular box for text or content.

Empty rectangular box for text or content.

Empty rectangular box for text or content.

SET SUGGESTIONS

Empty rectangular box for text or content.



D01

Rhinoplastik
Rhinoplasty
Rinoplastia
Rhinoplastie
Rinoplastica

GUBISCH



PART 1

Item number	Description	Quantity
01.22.15	Scalpel blade · figure 15 · packing unit 100 pieces · sterile	1
01.27.07	Scalpel handle · no 7 · 16.5 cm	1
02.27.12	Delicate scissors · curved · sharp/sharp · 12 cm	1
03.06.13	Operating scissors · straight · sharp/blunt · 13 cm	1
03.57.65	MAYO-STILLE "HM" Dissecting scissors · curved · 15 cm	1
04.67.14	REYNOLDS (JAMESON) Dissecting scissors · curved · 14 cm	1
06.20.62	ADSON "HM" Dressing forceps · 12 cm	1
06.23.12	MICRO-ADSON Tissue forceps · 1 x 2 teeth · 12 cm	2
06.25.12	ADSON-BROWN Tissue forceps · 7 x 7 teeth · 12 cm	1
06.45.20	Dressing forceps · serrated · 20 cm	1
07.19.15	NELSON Tissue grasping forceps · 15 cm	1
07.30.16	GRUENWALD Forceps · serrated · 16 cm	1
10.12.61	GUBISCH "HM" Needle holder · fine · 12.5 cm	1
10.20.65	CRILE-WOOD "HM" (DEBAKEY "HM") Needle holder · fine · 15 cm	1
15.40.12	MICRO-HALSTED Hemostatic forceps · straight · 12.5 cm	1
→ 15.41.12	MICRO-HALSTED Hemostatic forceps · curved · 12.5 cm	1
15.58.15	LERICHE Hemostatic forceps · straight · 1 x 2 teeth · 15 cm	1
16.10.14	PEAN Hemostatic forceps · straight · 14 cm	2
17.55.13	BACKHAUS Towel clamp · 13 cm	1
19.09.17	Dressing forceps · curved · 17.5 cm	1
19.17.20	GROSS Dressing forceps · curved · 20 cm	1
20.35.01	BARSKY Hook · 1 tooth · 15 cm	2
20.50.05	JOSEPH Hook · 2 teeth · 5mm · 17 cm	1



Das Instrument ist zusätzlich in den Farben Pink und Grün erhältlich.
The instrument is also available in pink and green.
El instrumento está disponible adicionalmente en los colores rosa y verde.
L'instrument est également disponible en rose et en vert.
Lo strumento è disponibile anche nei colori rosa e verde.

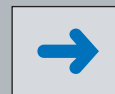

Instrumente, optional
Instruments optional
Instrumentos opcional
Instrumenti opzionale

GUBISCH



PART 2

Item number	Description	Quantity
20.52.10	GUTHRIE Hook · 2 teeth · sharp · 1.5 mm · 13 cm	1
26.29.07	LANGENBECK Elevator · 7 mm · 20 cm	1
26.35.01	FREER Raspatory · sharp/sharp · 5 mm · 19 cm	1
26.42.05	WILLIGER Raspatory · 5 mm · 16 cm	1
26.42.23	McKENTY Raspatory · 3 mm · 15 cm	1
→ 26.42.24	McKENTY Raspatory · 4 mm · 15 cm	1
27.10.32	Mallet · made of Novotex plastic · Ø 45 mm · 240 g · 26 cm	1
44.90.70	GUBISCH Pen holder · 13 cm	1
44.90.72	Feather · no 46 · for marking · packing unit 10 pieces	1
47.31.01	Round bowl · Ø 40 mm · height 20 mm · 20 ml	1
47.31.02	Round bowl · Ø 60 mm · height 30 mm · 60 ml	1
47.31.04	Round bowl · Ø 80 mm · height 40 mm · 160 ml	1
47.31.06	Round bowl · Ø 110 mm · height 55 mm · 400 ml	1
60.00.40	CASTROVIEJO Caliper · measuring range 20 mm · 8 cm	1
60.05.12	DESMARRES Lid retractor · figure 2 · 14 mm · 14 cm	1
63.45.11	Surgical hand piece · with irrigation tube · 11 cm	1
→ 63.45.13	Surgical hand piece · with irrigation tube · 13 cm	1
63.56.20	Cutting burr · barrel style · Ø 5 mm · shank Ø 2.35 mm · 7 cm	1
66.08.59	KILLIAN Nasal speculum · figure 4 · 90 mm · dismantable · 14 cm	1
66.28.03	WEIL-BLAKESLEY Nasal forceps · straight · 4.2 mm · 12 cm	1
66.52.10	FREER Mucosa knife · 16 cm	1
67.03.52	COTTLE Nasal speculum · 50 mm · 13 cm	1
67.15.98	HARALDSSON Suction elevator · Ø 3 mm · tube connection · 18.5 cm	1
67.16.70	DANIEL Spina nasalis awl · 16 cm	1



Das Instrument ist zusätzlich in den Farben Pink und Grün erhältlich.
The instrument is also available in pink and green.
El instrumento está disponible adicionalmente en los colores rosa y verde.
L'instrument est également disponible en rose et en vert.
Lo strumento è disponibile anche nei colori rosa e verde.



Instrumente, optional
Instruments optional
Instrumentos opcional
Instruments optionnel
Strumenti opzionale



GUBISCH



PART 3

Item number	Description	Quantity
67.19.76	Cartilage cutting block · made of PPSU · black · 85 × 55 × 10 mm	1
67.19.79	Cartilage cutting block with grooves · made of aluminium · 85 × 55 × 10 mm	1
67.19.80	COTTLE Cartilage crusher	1
67.19.81	Cartilage cutting block · made of PROPYLUX · 120 × 120 × 15 mm	1
67.20.07	GUBISCH-KILNER Alar retractor · 10 mm · 8 cm	1
67.21.32	GUBISCH-AUFRICHT Nasal retractor · 30 × 6/10 mm · 17 cm	1
→ 67.21.33	GUBISCH-AUFRICHT Nasal retractor · 50 × 6/12 mm · 17 cm	1
67.30.15	COTTLE-GUBISCH Chisel · graduated · hollow cut · 5 mm · 18 cm	1
67.30.22	COTTLE-GUBISCH Chisel · graduated · hollow cut · 12 mm · 18 cm	1
67.30.52	GUBISCH Osteotome · with aluminium handle · 2 mm · 18.5 cm	1
→ 67.30.53	GUBISCH Osteotome · with aluminium handle · 3 mm · 18.5 cm	1
67.33.03	FANOUS-GUBISCH Osteotome · 4 mm · 19.5 cm	1
67.53.71	CAPLAN Nasal septum scissors · angled · 20 cm	1
67.58.42	AIACH-GUBISCH Forceps · 16 cm	1
→ 67.58.44	AIACH-GUBISCH Forceps · flexible · 16 cm	1
67.61.00	Handle for nasal rasps · 14 cm	1
67.61.01	Handle for nasal rasps · double-ended · 14 cm	1
67.61.03	Wrench · for nasal rasps	1
→ 67.61.10	Rasps insert "HM" · figure 1	1
67.61.11	Rasps insert "HM" · figure 2	1
→ 67.61.12	Rasps insert "HM" · figure 3	1
→ 67.61.13	Rasps insert "HM" · figure 4	1
67.61.14	Rasps insert "HM" · figure 5	1
→ 67.61.15	Rasps insert "HM" · figure 6	1
→ 67.61.16	Rasps insert "HM" · figure 7	1
→ 67.61.17	Rasps insert "HM" · figure 8	1
→ 67.61.18	Rasps insert "HM" · figure 9	1
→ 67.61.19	Rasps insert "HM" · figure 10	1



Das Instrument ist zusätzlich in den Farben Pink und Grün erhältlich.
The instrument is also available in pink and green.
El instrumento está disponible adicionalmente en los colores rosa y verde.
L'instrument est également disponible en rose et en vert.
Lo strumento è disponibile anche nei colori rosa e verde.

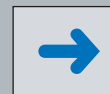

Instrumente, optional
Instruments optional
Instrumentos opcional
Instruments optionnel
Strumenti opzionale



GUBISCH



PART 4

Item number	Description	Quantity
67.65.71	Protective cap · for Rubin Septal morselizer	1
67.65.72	GUBISCH-RUBIN "HM" Septal morselizer · 20 cm	1
68.61.03	LINDEMANN Burr · shank-Ø 2.35 mm · 45 mm	1
→ 68.61.05	LINDEMANN Burr · shank-Ø 2.35 mm · Ø 1.4 mm · 44.5 mm	1
→ 68.61.06	LINDEMANN Burr · shank-Ø 2.35 mm · Ø 1.4 mm · 70 mm	1
72.00.18	BUCHWALD Tongue spatula · 18/23 mm · 18 cm	1
88.00.20	Bipolar connecting cable · 3 m · Ø 12.5 mm	1
→ 88.00.21	Bipolar connecting cable · 4 m · Ø 12.5 mm	1
→ 88.00.22	Bipolar connecting cable · 3 m · Ø 4 mm	1
→ 88.00.23	Bipolar connecting cable · 3 m · Ø 8 mm	1
→ 88.00.24	Bipolar connecting cable · 5 m · Ø 8 mm	1
→ 88.00.27	Bipolar connecting cable · 5 m · Ø 4 mm	1
88.00.40	Bracket · for one high frequency cable · 22.5 cm	1
88.90.20	BINNER Coagulation electrode · bipolar · 18.5 cm	1
202.20.61	SC Plus iris scissors straight · 11.5 cm	1
203.50.64	MAYO Dissecting scissors · supercut plus · straight · 14 cm	1
203.51.67	MAYO Dissecting scissors · supercut plus · curved · 17 cm	1
204.33.68	METZENBAUM Dissecting scissors · supercut plus · curved · 18 cm	1
204.55.66	KELLY Dissecting scissors · supercut plus · curved · 16 cm	1
266.40.21	HEYMANN Rhinoplasty scissors · supercut · 18 cm	1
267.53.63	FOMON Rhinoplasty scissors · supercut plus · angled downwards · 13 cm	1
49.60.22	Medicontainer · silver · 590 × 290 × 220 mm	1
49.90.00	Tray · with silicone mat · 190 × 102 × 19 mm	1
49.97.21	Wire basket · 510 × 255 × 50 mm	2
49.97.22	Wire basket · 510 × 255 × 70 mm	2
49.97.82	Silicone mat · 13 mm · 467 × 240 mm	3



Das Instrument ist zusätzlich in den Farben Pink und Grün erhältlich.
The instrument is also available in pink and green.
El instrumento está disponible adicionalmente en los colores rosa y verde.
L'instrument est également disponible en rose et en vert.
Lo strumento è disponibile anche nei colori rosa e verde.



Instrumente, optional
Instruments optional
Instrumentos optional
Instruments optionnel
Strumenti opzionale



D01

Rhinoplastik
Rhinoplasty
Rinoplastia
Rhinoplastie
Rinoplastica

DANIEL

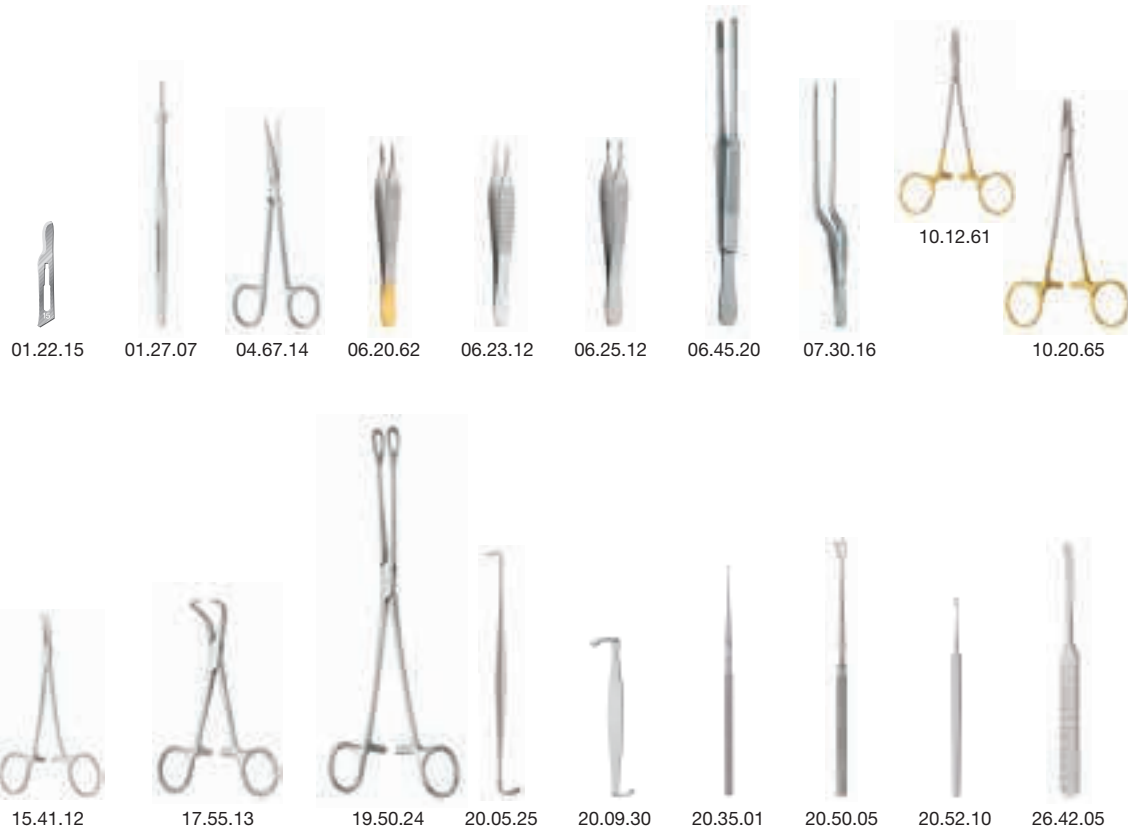

PART 1

Item number	Description	Quantity
01.22.15	Scalpel blade · figure 15 · sterile · packing unit 100 pieces	1
01.27.07	Scalpel handle · no. 7 · long · 16.5 cm	1
04.67.14	REYNOLDS (JAMESON) Scissors · curved · 14 cm	1
06.20.62	ADSON HM Dressing forceps · 12 cm	1
06.23.12	MICRO-ADSON Tissue forceps · 1 × 2 teeth · 12 cm	2
06.25.12	ADSON-BROWN Tissue forceps · 7 × 7 teeth · 12 cm	1
06.45.20	Dressing forceps · serrated · 20 cm	1
07.30.16	GRUENWALD Dressing forceps · 16 cm	1
10.12.61	GUBISCH "HM" Needle holder · fine · 12.5 cm	1
10.20.65	CRILE-WOOD HM (DEBAKEY HM) Needle holder · fine · 15 cm	1
15.41.12	MICRO-HALSTED Hemostatic forceps · curved · 12.5 cm	2
17.55.13	BACKHAUS Towel clamp · 13 cm	3
19.50.24	FOERSTER Sponge forceps · straight · 24 cm	2
20.05.25	RAGNELL Delicate retractor · double-ended · 16 cm	2
20.09.30	CRILE Retractor · double-ended · 11 cm	1
20.35.01	BARSKY Skin hook · 1 tooth · 15 cm	1
20.50.05	JOSEPH Delicate retractor · 2 teeth · sharp · 17 cm	2
20.52.10	GUTHRIE Delicate retractor · 2 teeth · sharp · 13 cm	2
26.42.05	WILLIGER Raspatory · 5 mm · 16 cm	1



DANIEL



PART 2

Item number	Description	Quantity
26.42.23	McKENTY Raspatory · 3 mm · 15 cm	1
26.44.04	JOSEPH Raspatory · 4 mm · slightly curved · 16 cm	1
27.10.32	Mallet · made of Novotex plastic · Ø 45 mm · 240 g · 26 cm	1
44.37.15	Ruler · graduated in mm and inches · 15 cm	1
47.31.02	Round bowl · Ø 60 mm · height 30 mm · 0.06 l	1
47.31.06	Round bowl · Ø 110 mm · height 55 mm · 0.40 l	1
47.50.50	Medicine cup · graduated · 50 cc	1
60.00.40	CASTROVIEJO Caliper · measuring range 20 mm · 8 cm	1
67.03.52	COTTLE Nasal specula · 50 mm · 13 cm	1
67.15.98	HARALDSSON Suction elevator · Ø 3mm · 18.5 cm	1
67.16.27	DANIEL-CAKIR Subperichondrial/subperiosteal elevator · 20 cm	1
67.16.28	DANIEL-CAKIR Subperichondrial/subperiosteal elevator · 20 cm	1
67.16.29	COTTLE-DANIEL Septal elevator · 21 cm	1
67.16.70	DANIEL Spina nasalis awl · 16 cm	1
67.19.77	Cartilage cutting block with grid · Propylux	1
67.19.80	GUBISCH Cartilage crusher · 65 × 30 mm	1
67.20.07	GUBISCH-KILNER Alar retractor · 10 mm · 8 cm	1
67.21.46	AUFRICHT-DANIEL Nasal retractor · 11 cm	1
67.30.52	GUBISCH Osteotome · straight · 2 mm · 18.5 cm	1
→ 67.30.53	GUBISCH Osteotome · straight · 3 mm · 18.5 cm	1

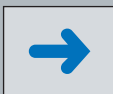

Instrumente, optional
Instruments optional
Instrumentos opcional
Instruments optionnel
Strumenti opzionale



D01

Rhinoplastik
Rhinoplasty
Rinoplastia
Rhinoplastie
Rinoplastica

DANIEL

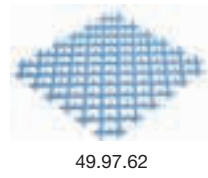

PART 3

Item number	Description	Quantity
67.30.60	CAKIR Osteotome · straight · without guide	1
67.33.03	FANOUS-GUBISCH Osteotome · with guide · 3 mm · 19.5 cm	1
67.58.42	AIACH-GUBISCH Forceps · 16 cm	1
67.61.01	Handle for nasal rasps · double-ended · 14 cm	1
67.61.03	Wrench · for nasal rasp	1
67.61.14	“HM” Nasal rasps · figure 5	1
67.61.15	“HM” Nasal rasps · figure 6	1
203.50.67	MAYO Dissecting scissors · supercut plus · straight · 17 cm	1
214.52.15	DANIEL Dissecting scissors · black line · straight · 15 cm	1
214.53.15	JOSEPH-DANIEL Dissecting scissors · black line · curved · blunt · 15 cm	1
214.53.16	JOSEPH-DANIEL Dissecting scissors · black line · curved · sharp · 15 cm	1
277.53.90	CONVERSE-DANIEL Dissecting scissors · black line · blunt · 9.5 cm	1
49.50.13	Medicontainer · silver · 290 × 290 × 135 mm	1
49.97.02	Wire basket · 240 × 255 × 50 mm	1
49.97.62	Silicone mat · distance between naps 6 mm · 240 × 220 mm	2



Item number	Description	Quantity
01.22.10	Scalpel blade · figure 10 · sterile · packing unit 100 pieces	1
01.27.03	Scalpel handle · no 3 · standard · 12.5 cm	1
02.50.03	STEVENS scissors · curved · sharp · 11.5 cm	1
06.31.20	Iris forceps · half curved · 1 × 2 teeth · 10 cm	1
07.00.10	GRAEFE Fixation forceps · straight · 11 cm	1
09.83.30	FRAZIER (FERGUSON) Suction cannula · 10 French · angled · 12.5 cm	1
10.12.63	HALSEY "HM" Needle holder · serrated · 13.5 cm	1
15.45.12	HALSTED-MOSQUITO Forceps · curved · 12.5 cm	2
17.55.08	BACKHAUS Towel clamp · 8.5 cm	4
19.17.20	GROSS Dressing forceps · curved · 20 cm	1
20.31.15	LAHEY-CLINIC Dura hook · 13 cm	2
20.48.10	BENICKE Retractor · 8 mm · sharp · 19 cm	1
60.00.40	CASTROVIEJO Caliper · 20 mm · 8 cm	1
60.05.11	DESMARRES Lid retractor · 12 mm · figure 1 · 14 cm	2
60.55.40	WALTER Lid forceps · 8 cm	1
67.58.54	ALAMUTI Marking forceps · 10 mm · 9.5 cm	1
202.50.13	STEVENS Scissors · supercut · curved · blunt · 11.5 cm	1
204.11.11	SIEGERT Scissors · supercut · curved · 11.5 cm	1
49.50.10	Medicontainer · silver · 290 × 290 × 100 mm	1
49.97.02	Wire basket · 240 × 255 × 50 mm	1
49.97.62	Silicone mat · 6 mm · 240 × 220 mm	1



D03

Lipofilling
Lipofilling
Lipofilling
Lipostructure
Lipofilling



Item number	Description	Quantity
09.87.20	TOLEDO Liposuction cannula · fork shape · Ø 2 mm · 5 cm	1
09.87.50	Liposuction cannula · 1 hole · Ø 1.7 mm · 5 cm	1
09.87.57	Liposuction cannula · 1 hole · Ø 1.7 mm · 5 cm	1
09.87.60	ENTNER Liposuction cannula · Ø 2 mm · 18 holes · 15 cm	1
09.87.70	ENTNER Liposuction cannula · Ø 2 mm · 18 holes · 15 cm	1
09.87.80	Suction syringe · with vacuumstop · 10 ml	1
09.87.85	Connector · for handle · for liposuction cannula · 5 cm	1
09.87.86	Holding device for liposuction syringes · Ø 40 mm	1
09.87.93	Lipoinjection dosage handle for 1 ml syringe	1
09.87.94	Plastic syringe for lipoinjection · 1 ml · Luer-Lock · packing unit 100 pieces	1
09.87.83	Transfer adaptor for Luer-Lock syringes · 2 cm	1
09.89.15	Cannula for lipoinjection · Ø 0.7 mm · 4 cm	1
09.89.16	Cannula for lipoinjection · Ø 0.9 mm · 4 cm	1
09.89.17	Cannula for lipoinjection · Ø 1.2 mm · 5 cm	1
09.89.18	Cannula for lipoinjection · Ø 1.5 mm · 6 cm	1
09.89.22	TOLEDO Cannula for autologous fat transfer · 1 hole · Ø 1.5 mm · 7 cm	1
09.89.24	von GREGORY Cannula for autologous fat transfer · 4 hole · Ø 2.5 mm · 15 cm	1
09.89.26	von GREGORY Cannula for autologous fat transfer · 4 hole · Ø 3.0 mm · 18 cm	1
09.89.28	von GREGORY Cannula for autologous fat transfer · 16 hole · Ø 2.0 mm · 15 cm	1
49.40.39	Medicontainer · 300 × 135 × 47 mm · gold	1
49.97.76	Silicone mat · 13 mm · 275 × 125 mm	1



Item number	Description	Quantity
01.22.11	Scalpel blade · fig. 11 · sterile · packing unit 100 pieces	1
01.27.17	Scalpel handle · no 7K · 12 cm	1
01.30.38	BLAKE Blade holder · angled · 15.5 cm	1
09.83.07	STILLER Suction cannula · 6 French · angled · 12.5 cm	1
12.18.74	MICRO 2000 Needle holder · straight · with catch · 18 cm	1
13.71.58	MICRO Suture forceps · straight · 1 × 2 teeth · 15 cm	1
26.37.08	STILLER Raspatory · sharp · double ended · 18 cm	1
29.68.42	DAUBENSPECK Sharp curette · figure 00 · 20 cm	1
63.45.11	Surgical hand piece · with irrigation tube · 11 cm	1
63.54.30	Diamond burr · 70 mm · 3.0 mm	1
68.82.53	STILLER Elevator · for sinuslift · 3 mm · double ended	3
→ 68.82.54	STILLER Elevator · for sinuslift · 4 mm · double ended	1
→ 68.82.55	STILLER Elevator · for sinuslift · 6 mm · double ended	1
68.82.56	STILLER Elevator · for sinuslift · 3 mm · 90° · double ended · 20 cm	1
68.82.57	STILLER Elevator · for sinuslift · retrograde · double ended · 22 cm	1
68.82.58	STILLER Elevator · for sinuslift · double ended · 18 cm	1
205.18.71	MICRO 2000 Scissors · supercut · curved · 18 cm	1
49.50.10	Medicontainer · 290 × 290 × 100 mm · silver	1
49.90.04	Tray · with fixation strips · for 12 instruments	1
49.97.02	Wire basket · 240 × 255 × 50 mm	1

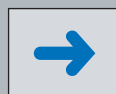

Instrumente, optional
Instruments optional
Instrumentos opcional
Instruments optionnel
Strumenti opzionale



Mikrochirurgischer Gaumenverschluss
Microsurgical Palate Closure
Cierre del paladar con microcirugía
Fermeture microchirurgicale du palais
Chiusura microchirurgica del palato

D05



PART 1

Item number	Description	Quantity
01.22.15	Scalpel blade · figure 15 · sterile · packing unit 100 pieces	1
01.27.07	Scalpel handle · no 7 · 16.5 cm	1
03.07.14	Operating scissors · curved · sharp/blunt · 14.5 cm	1
04.33.14	METZENBAUM Scissors · curved · 14 cm	1
04.71.19	DEMARTEL Vascular scissors · curved · 18 cm	1
06.01.14	Dressing forceps · medium width · 14.5 cm	1
06.35.58	SELECT Tissue forceps · 1 × 2 teeth · 18 cm	2
06.60.68	CUSHING "HM" Dressing forceps · with dissector end · 18 cm	1
09.79.85	Cannula with olive · curved · Ø 1.8 mm · 8 cm	2
09.84.08	PLESTER Suction tube · 8 French · working length 13.5 cm	1
11.34.88	TOENNIS "HM" Needle holder · 18 cm	1
15.44.12	HALSTED-MOSQUITO Hemostatic forceps · straight · 12.5 cm	4
17.54.10	TOHOKU Towel clamp · 10 cm	5
19.17.20	GROSS Dressing forceps · curved · 20 cm	1
20.30.20	GILLIES Delicate retractor · large · 19 cm	1
26.35.00	FREER-SCHEER Elevatory · 3.5 mm · double-ended · sharp/blunt · 19 cm	1
26.42.05	WILLIGER Raspatory · 5 mm · 16 cm	1
30.76.17	STELLBRINK Bone rongeur · light curved · 17 cm	1
45.52.30	KOELN Mouth gag for children · complete · consisting of:	1
	45.52.31 Frame with a pair of tooth hooks · curved	1
	45.57.11 Tongue depressor · 65 × 28 mm	1
	72.08.11 Tongue depressor · 55 × 25 mm	1
	72.08.12 Tongue depressor · 60 × 27 mm	1
	72.08.13 Tongue depressor · 70 × 30 mm	1
47.32.12	Round bowl · Ø 130 mm · height 35 mm · 250 ml	1



Mikrochirurgischer Gaumenverschluss
Microsurgical Palate Closure
Cierre del paladar con microcirugía
Fermeture microchirurgicale du palais
Chiusura microchirurgica del palato

D05



PART 2

Item number	Description	Quantity
60.34.21	BOWMAN (WILLIAMS) Lacrimal probe · nickel silver · figure 00-0 · 13 cm	1
68.01.44	OBWEGESER Soft tissue retractor · 42 × 10 mm · 22.5 cm	1
68.81.31	BLOCKSMA Cleft palate hook · 1 teeth · 18 cm	1
68.81.32	BLOCKSMA Cleft palate hook · 2 teeth · 3 mm · 18 cm	1
68.82.79	WANG Cleft palate raspatory · strong · curved · 15.5 cm	1
68.82.81	WANG Cleft palate raspatory · right · 18 cm	1
68.82.82	WANG Cleft palate raspatory · left · 18 cm	1
68.82.83	WANG Cleft palate raspatory · right · angled · 18 cm	1
68.82.84	WANG Cleft palate raspatory · left · angled · 18 cm	1
72.00.52	HANNA Tongue spatula · 20 cm	1
72.00.56	CLAUDINHA Tongue spatula · 21 cm	1
72.05.63	DENHART-HOEFERT Mouth gag · 12.5 cm	1
88.00.21	Bipolar connecting cable · Ø 12.5 mm · length 4 m	1
88.00.40	Bracket · for high frequency cable · 22.5 cm	1
88.20.08	Coagulation forceps · bipolar · angled · blunt · 20 cm	1
204.25.18	SLIM Dissecting scissors · supercut · curved · 18 cm	1
204.33.14	METZENBAUM Dissecting scissors · supercut · curved · 14 cm	1
204.51.15	JOSEPH Delicate dissecting scissors · supercut · curved · 15 cm	1
331.11.04	Mouth mirror · magnifying · figure 4 · Ø 22 mm · packing unit 12 pieces	1
331.50.10	Mouth mirror handle · 12 cm	1
332.10.20	LONDON-COLLEGE Dental plier · serrated · 15 cm	1
335.01.91	Dental probes · figure 9a · with point set in · 15 cm	1
49.60.15	Medicontainer · 590 × 290 × 150 mm · silver	1
49.90.00	Tray for delicate instruments with silicone mat · stackable · 190 × 102 × 19 mm	1
49.97.12	Wire basket · 480 × 255 × 50 mm	2



Lippen-, Kiefer- und Gaumenspalten
Lip, Jaw and Palate Fissures
Fisuras palatinas, labiales y maxilares
Fentes labiales, maxillaires et palatines
Labio-palatoschisi

D06



PART 1

Item number	Description	Quantity
01.22.10	Scalpel blade · figure 10 · sterile · packing unit 100 pieces	1
01.22.11	Scalpel blade · figure 11 · sterile · packing unit 100 pieces	1
01.27.03	Scalpel handle · no 3 · standard · 12.5 cm	2
01.27.07	Scalpel handle · no 7 · long · 16.5 cm	2
03.51.64	MAYO "HM" Scissors · curved · 14.0 cm	1
06.20.12	ADSON Dressing forceps · serrated · 12 cm	1
06.25.12	ADSON Brown Tissue forceps · straight · 7 × 7 teeth · 12 cm	1
06.40.85	GILLIES Tissue forceps · 1 × 2 teeth · 15 cm	2
06.52.15	DEBAKEY AT Vascular forceps · 2.0 mm · 15 cm	1
06.60.92	GERALD Tissue forceps · straight · 1 × 2 teeth · 18 cm	1
09.08.16	Myrtle leaf probe · 16.0 cm	1
09.79.71	Infusion cannula · with olive · 1.2 × 80 mm	1
→ 09.79.76	Infusion cannula · with olive · 2.0 × 80 mm	1
09.83.30	FRAZIER (FERGUSON) Suction cannula · 10 French · angled · 12.5 cm	1
10.12.63	HALSEY "HM" Needle holder · serrated · 13.5 cm	1
10.20.68	CRILE-WOOD "HM" (DEBAKEY "HM") Needle holder · fine · 18 cm	1
11.62.15	CASTROVIEJO Needle holder · curved · 14 cm	1
15.10.38	DIEFFENBACH Bulldog clamp · straight · 3.8 cm	2
15.35.09	HARTMANN (BABY MOSQUITO) Hemostatic forceps · 1×2 teeth · curved · 10 cm	4
15.41.82	MICRO-JACOBSON Hemostatic forceps · curved · 12.5 cm	4
15.45.22	Hemostatic forceps · ultra delicate · curved · 12.5 cm	1
16.40.18	HALSTED (ADSON) Hemostatic forceps · straight · 18 cm	2
17.55.10	BACKHAUS Towel clamp · 10.5 cm	2
19.09.17	Dressing forceps · curved · delicate · 17.5 cm	1
19.17.20	GROSS Dressing forceps · curved · 20 cm	1



Instrumente, optional
 Instruments optional
 Instrumentos opcional
 Instruments optionnel
 Strumenti opzionale

**Lippen-, Kiefer- und Gaumenspalten
Lip, Jaw and Palate Fissures
Fisuras palatinas, labiales y maxilares
Fentes labiales, maxillaires et palatines
Labio-palatoschisi**

D06

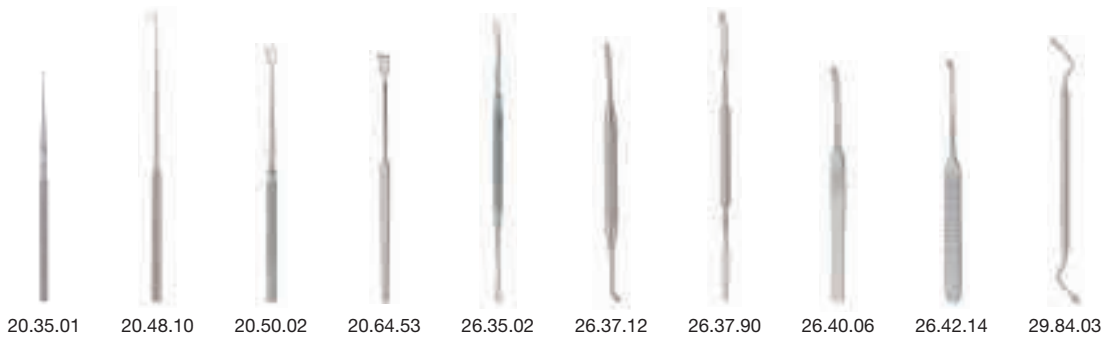

PART 2

Item number	Description	Quantity
20.35.01	BARSKY Hook · 1 tooth · 15 cm	2
20.48.10	BENICKE Retractor · 8 mm · sharp · 19 cm	1
20.50.02	JOSEPH Hook · 2 teeth · 2 mm · 17 cm	2
20.64.53	Retractor · flexible · 3 teeth · sharp · 7 mm · 16 cm	2
26.35.02	FREER Periosteal elevator · sharp/blunt · 5.0 mm · 19 cm	1
26.37.12	BENNET Elevator · double-ended · figure 12s · 17 cm	2
26.37.90	MACDONALD Dissector · double-ended · 6 mm · 19 cm	1
26.40.06	KOENIG Raspatory · 5 mm · 15 cm	1
26.42.14	KAHRE Williger Raspatory · 4 mm · 16 cm	2
29.84.03	HEMINGWAY Sharp curette · double-ended · figure 3 · 18 cm	1
31.05.02	RUSKIN Mini Bone rongeur · 2 mm · curved · 15 cm	1
31.11.04	BEYER Bone rongeur · 4 mm · curved · 18 cm	1
44.37.15	Rule · stainless steel · 15 cm	1
45.52.30	KOELN Mouth gag for children · complete · consisting of:	1
	45.52.31 Frame with a pair of tooth hooks · curved	1
	45.57.11 Tongue depressor · 65 × 28 mm	1
	72.08.11 Tongue depressor · 55 × 25 mm	1
	72.08.12 Tongue depressor · 60 × 27 mm	1
	72.08.13 Tongue depressor · 70 × 30 mm	1
46.37.50	Needle case · Ø 65 mm	1
47.20.25	Kidney basin · 250 × 125 × 35 mm	1
47.31.06	Round bowl · Ø 110 mm · height 55 mm · 400 ml	1
60.00.40	CASTROVIEJO Caliper · 20 mm · 8 cm	1
67.20.11	COTTLE Skin hook · 2 teeth · sharp · 10 mm · 14 cm	1
67.20.22	COTTLE Skin hook · 2 teeth · sharp/ball tip · 10 mm · 14 cm	1
67.20.50	MASING Retractor · knife guide · 20 cm	2





**Lippen-, Kiefer- und Gaumenspalten
Lip, Jaw and Palate Fissures
Fisuras palatinas, labiales y maxilares
Fentes labiales, maxillaires et palatines
Labio-palatoschisi**

D06



PART 3

Item number	Description	Quantity
68.01.42	OBWEGESER Soft tissue retractor · down · 7 × 25 mm	2
→ 68.01.45	OBWEGESER Soft tissue retractor · down · 12 × 55 mm	1
→ 68.01.46	OBWEGESER Soft tissue retractor · down · 14 × 70 mm	1
68.02.20	OBWEGESER-FREER Elevator · sharp/blunt · 21 cm	3
68.02.22	OBWEGESER-FREER Raspatory · double ended · 20.5 cm	1
68.81.31	BLOCKSMA Cleft palate hook · 1 tooth · 18 cm	1
→ 68.81.32	BLOCKSMA Cleft palate hook · 2 teeth · 18 cm	1
68.82.11	Cleft palate raspatory · left · 14 cm	1
68.82.12	Cleft palate raspatory · right · 14 cm	1
68.82.20	KAHRE Cleft palate raspatory · 17 cm	4
68.82.80	WANG Cleft palate raspatory · 15.5 cm	1
68.82.81	WANG Cleft palate raspatory · right · 18 cm	1
68.82.82	WANG Cleft palate raspatory · left · 18 cm	1
68.82.83	WANG Cleft palate elevator · right · angled · 18 cm	1
68.82.84	WANG Cleft palate elevator · left · angled · 18 cm	1
72.00.52	HANNA Tongue spatula · 20 cm	1
72.00.56	CLAUDINHA Tongue spatula · 21 cm	1
72.05.63	DENHART-HOEFERT Mouth gag · 12.5 cm	1
88.00.20	Bipolar cable · Ø 12.5 mm · 3 m	1
88.00.40	Bracket · for high frequency cable · 22.5 cm	1
88.17.08	Bipolar forceps · angled · blunt · 16.5 cm	2
204.11.11	SIEGERT Scissors · supercut · curved · 11.5 cm	2
204.13.13	RAGNELL (KILNER) Scissors · supercut · 13 cm	1
204.35.68	METZENBAUM-SLIM Scissors · supercut plus · curved · 18 cm	1
204.65.15	Dissecting scissors · supercut · delicate · curved · sharp · 15 cm	1
204.67.16	REYNOLDS (JAMESON) Scissors · supercut · curved · 16 cm	1
331.11.04	Mouth mirror · magnifying · figure 4 · packing unit 12 pieces	1
331.50.20	Mouth mirror handle	1
49.60.17	Medicontainer · silver · 590 × 290 × 170 mm	1
49.97.21	Wire basket · 510 × 255 × 50 mm	3



Instrumente, optional
Instruments optional
Instrumentos opcional
Instruments optionnel
Strumenti opzionale



PART 1

Item number	Description	Quantity
01.22.10	Scalpel blade · figure 10 · sterile · packing unit 100 pieces	1
01.22.11	Scalpel blade · figure 11 · sterile · packing unit 100 pieces	1
01.27.03	Scalpel handle · no 3 · standard · 12.5 cm	1
01.27.07	Scalpel handle · no 7 · long · 16.5 cm	1
03.51.15	Mayo Scissors · curved · 15.5 cm	1
04.21.14	BROPHY (SULLIVAN) Scissors · curved · 14 cm	1
04.71.19	DEMARTEL Vascular scissors · curved · blunt · 18 cm	1
06.01.16	Dressing forceps · medium · 16.0 cm	1
06.05.18	Tissue forceps · 1 × 2 teeth · standard · 18.0 cm	1
06.10.14	Tissue forceps · 2 × 3 teeth · 14.5 cm	1
→ 06.11.16	Tissue forceps · 3 × 4 teeth · 16.0 cm	1
06.23.12	MICRO-ADSON Tissue forceps · 1 × 2 teeth · 12 cm	2
06.60.68	CUSHING "HM" Dressing forceps · straight · 18 cm	2
06.60.92	GERALD Tissue forceps · straight · 1 × 2 teeth · 18 cm	1
07.35.13	TROELTSCH (WILDE) Ear forceps · 13 cm	1
07.35.17	TROELTSCH Nasal forceps · serrated · 17 cm	1
09.08.13	Myrtle leaf probe · 13.0 cm	1
09.79.71	Infusion cannula · with olive · 1.2 × 80 mm	1
→ 09.79.76	Infusion cannula · with olive · 2.0 × 80 mm	1
09.83.30	FRAZIER (FERGUSSON) Suction cannula · 10 French · angled · 12.5 cm	1
10.12.61	GUBISCH "HM" Needle holder · fine · 12.5 cm	1
10.20.64	BABY-CRILE-WOOD HM Needle holder · 15 cm	1
11.22.70	MATHIEU "HM" Needle holder · 20 cm	1
14.23.62	UNIVERSAL "HM" Wire cutting scissors · 12 cm	1

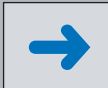

Instrumente, optional
Instruments optional
Instrumentos opcional
Instruments optionnel
Strumenti opzionale



D07

Dysgnathie
Dysgnathia
Disgnacia
Dysgnathie
Disgnatia



PART 2

Item number	Description	Quantity
15.28.14	PEAN-BABY Hemostatic forceps · straight · 14 cm	2
15.45.12	HALSTED-MOSQUITO Forceps · curved · 12.5 cm	5
15.57.15	LERICHE Hemostatic forceps · curved · 15 cm	3
16.64.18	OVERHOLT-SLIM Forceps · 18.5 cm	1
17.55.10	BACKHAUS Towel clamp · 10.5 cm	4
17.73.14	Tubing clamp jaws · serrated · 14.5 cm	3
19.09.17	Dressing forceps · curved · delicate · 17.5 cm	1
19.15.20	GROSS Dressing forceps · curved · 20 cm	1
19.17.20	GROSS Dressing forceps · curved · 20 cm	1
20.12.75	STRANDELL-STILLE Retractor · 6 x 15 mm · 17 cm	2
20.30.19	GILLIES Hook · small · 19 cm	2
20.50.05	JOSEPH Hook · 2 teeth · 5 mm · 17 cm	1
22.30.04	VOLKMANN Retractor · 4 teeth · sharp · 18 mm · 21 cm	1
26.37.08	STILLER Raspatory · sharp · double-ended · 18 cm	1
26.42.05	WILLIGER Raspatory · 5 mm · 16 cm	1
26.42.58	Raspatory · 8 mm · 17 cm	1
26.60.35	LANGENBECK Raspatory · 15 mm · 19 cm	1
27.10.32	Fibre mallet · Ø 45 mm · 240 g · 26 cm	1
27.57.04	MINI-LAMBOTTE Osteotome · 4 mm · 13 cm	1
→ 27.57.06	MINI-LAMBOTTE Osteotome · 6 mm · 13 cm	1
→ 27.57.08	MINI-LAMBOTTE Osteotome · 8 mm · 13 cm	1
27.61.03	PARTSCH Chisel · 3 mm · 14 cm	1
→ 27.61.04	PARTSCH Chisel · 4 mm · 14 cm	1
→ 27.61.06	PARTSCH Chisel · 6 mm · 14 cm	1



Instrumente, optional
Instruments optional
Instrumentos opcional
Instruments optionnel
Strumenti opzionale



PART 3

Item number	Description	Quantity
27.95.03	Bone tamper · Ø 3 mm · 16 cm	1
→ 27.95.05	Bone tamper · Ø 6 mm · 16 cm	1
→ 27.95.07	Bone tamper · Ø 7 mm · 16 cm	1
28.62.08P	MINI-LEXER Gouge · 8 mm · 18 cm	1
29.51.51	VOLKMANN Sharp curette · figure 1 · 17 cm	1
→ 29.51.55	VOLKMANN Sharp curette · figure 5 · 17 cm	1
29.69.52	HALLE Sharp curette · malleable · figure 2 · 21 cm	1
29.83.72	JANSEN Sharp curette · double-ended · 3/4 mm · 17 cm	1
30.25.30	BLUMENTHAL Bone rongeur · 30° · 16 cm	1
35.15.18	DINGMAN Bone holding forceps · 19 cm	1
44.90.70	GUBISCH Penholder · 13 cm	1
44.90.72	Feather · no 46 · for marking · packing unit 10 pieces	1
47.20.25	Kidney basin · 250 × 125 × 35 mm	1
47.31.02	Round bowl · Ø 60 mm · height 30 mm · 60 ml	1
→ 47.31.04	Round bowl · Ø 80 mm · height 40 mm · 160 ml	1
47.45.12	Cotton container · with lid · 120 × 110 mm	1
60.00.40	CASTROVIEJO Caliper · 20 mm · 8 cm	1
60.00.42	CASTROVIEJO-EPKER Caliper · straight · 40 mm · 18 cm	1
60.05.95	JAEGER Lid plate · 11 cm	1
66.52.10	FREER Septum knife · D model · 16 cm	1
66.54.10	KILLIAN Septum elevator · double-ended · sharp/blunt · 18 cm	1
67.02.35	COTTLE Nasal speculum · figure 1 · 35 mm · 14 cm	1
→ 67.02.55	COTTLE Nasal speculum · figure 2 · 55 mm · 14 cm	1



Instrumente, optional
Instruments optional
Instrumentos opcional
Instruments optionnel
Strumenti opzionale



D07

**Dysgnathie
Dysgnathia
Disgnacia
Dysgnathie
Disgnatia**



PART 4

Item number	Description	Quantity
67.37.25	SCHROM Osteotome · with guide · 3 mm · straight · 19.5 cm	1
→ 67.37.30	SCHROM Osteotome · with guide · 3 mm · left · 19.5 cm	1
→ 67.37.35	SCHROM Osteotome · with guide · 3 mm · right · 19.5 cm	1
68.01.35	OBWEGESER Soft tissue retractor · up · 12 × 55 mm · 23 cm	1
→ 68.01.37	OBWEGESER Soft tissue retractor · up · 16 × 80 mm · 23 cm	1
68.01.45	OBWEGESER Soft tissue retractor · down · 12 × 55 mm · 22.5 cm	1
→ 68.01.47	OBWEGESER Soft tissue retractor · down · 16 × 80 mm · 22.5 cm	1
68.01.72	OBWEGESER Ramus clamp · wide · right · 19 cm	1
→ 68.01.73	OBWEGESER Ramus clamp · wide · left · 19 cm	1
68.01.80	OBWEGESER Mandibular channel retractor · 8 mm · 17.5 mm	1
→ 68.01.81	OBWEGESER Mandibular channel retractor · 10 mm · 17.5 mm	1
68.01.82	OBWEGESER Chin retractor · 16 cm	1
68.01.99	Vestibulum retractor · universal · 15 cm	1
68.02.11	OBWEGESER Raspatory · curved · 15 mm · 20 cm	1
68.02.21	OBWEGESER-FREER Raspatory · double-ended · 21 cm	1
68.03.07P	OBWEGESER Splitting osteotome · 7 mm · 21.5 cm	1
→ 68.03.10P	OBWEGESER Splitting osteotome · 10 mm · 21.5 cm	1
68.03.30	OBWEGESER Osteotome · 10 mm · curved · 23.5 cm	1
68.03.75	OBWEGESER Septal osteotome · 18.5 cm	1
68.04.05	OBWEGESER Mandibular awl · 14 cm	1
68.04.10	OBWEGESER Awl · for zygomatic arch · 23 cm	1
68.04.15	OBWEGESER Maxillary awl · 18 cm	1
68.05.20	WANGERIN Mandibular ramus positioning instrument · 18 cm	1
68.05.30	KRETSCHMER Retractor · with drill device · 12 × 60 mm · 21 cm	1
68.18.91	WASSMUND Retractor · 33 × 21 mm · 20.5 cm	1



Instrumente, optional
Instruments optional
Instrumentos opcional
Instruments optionnel
Strumenti opzionale



PART 5

Item number	Description	Quantity
72.00.52	HANNA Tongue spatula · 20 cm	1
72.00.56	CLAUDINHA Tongue spatula · 21 cm	1
72.02.15	STERNBERG Cheek retractor · 14.5 cm	2
72.05.63	DENHART-HOEFERT Mouth gag · 12.5 cm	1
76.01.03	Suture wire · soft · 0.30 mm · coil / 10 m	1
→ 76.01.04	Suture wire · soft · 0.40 mm · coil / 10 m	1
→ 76.01.05	Suture wire · soft · 0.50 mm · coil / 10 m	1
77.10.20	DINGMAN Bone hook · 20 mm · 19 cm	1
87.32.12	Needle electrode · straight · Ø 4.0 mm	1
→ 87.32.14	Needle electrode · angled · Ø 4.0 mm	1
87.33.70	Electrode handle · Ø 4.0 mm · with cable · 4.5 m	1
88.00.20	Bipolar cable · Ø 12.5 mm · 3 m	1
88.00.40	Bracket · for high frequency cable · 22.5 cm	1
88.17.08	Bipolar forceps · angled · blunt · 16.5 cm	1
204.11.11	SIEGERT Scissors · supercut · curved · 11.5 cm	1
204.33.18	METZENBAUM Scissors · supercut · curved · 18 cm	1
204.63.18	TOENNIS ADSON Scissors · supercut · curved · 18 cm	1
204.67.16	REYNOLDS (JAMESON) Scissors · supercut · curved · 16 cm	1
330.01.85	LUNIATSCHEK Gauze packers · blunt · 3 mm · 18 cm	2
331.10.03	Mouth mirror · plane · figure 3 · packing unit 12 pieces	1
331.50.20	Mouth mirror handle	1
332.10.21	LONDON-COLLEGE Dental plier · smooth · 15 cm	1
335.01.91	Dental explorer · figure 9a · 15 cm	1
49.60.22	Medicontainer · 590 × 290 × 220 mm · silver	1
49.97.21	Wire basket · 510 × 255 × 50 mm	1
49.97.22	Wire basket · 510 × 255 × 70 mm	2

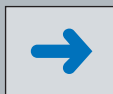

Instrumente, optional
Instruments optional
Instrumentos opcional
Instruments optionnel
Strumenti opzionale



D08

Spongiosaentnahme aus dem Beckenkamm
Removal of Spongiosa from the Iliac Crest
Extracción de sustancia esponjosa de la cresta iliaca
Prélèvement d'os spongieux sur la crête iliaque
Prelievo di spongiosa dalla cresta iliaca

“CRISTACA”



PART 1

Item number	Description	Quantity
01.22.10	Scalpel blade · figure 10 · sterile · packing unit 100 pieces	1
01.22.11	Scalpel blade · figure 11 · sterile · packing unit 100 pieces	1
01.27.03	Scalpel handle · no 3 · 12.5 cm	1
03.10.15	MIXTER Operating scissors · 15.5 cm	1
06.21.15	ADSON Tissue forceps · 1 × 2 teeth · 15 cm	1
06.22.15	MICRO-ADSON Dressing forceps · serrated · 15 cm	1
09.83.30	FRAZIER (FERGUSSON) Suction cannula · 10 French · working length = 12.5 cm	1
10.20.65	CRILE-WOOD “HM” (DEBAKEY “HM”) Needle holder · fine · 15 cm	1
15.44.12	HALSTED-MOSQUITO Hemostatic forceps · straight · 12.5 cm	1
15.72.64	CRILE Hemostatic forceps · straight · 14 cm	2
19.16.20	GROSS Dressing forceps · 20 cm	1
20.30.20	GILLIES Delicate retractor · 5 mm · 19 cm	2
22.16.14	ROUX Retractor · double-ended · 22 × 20 mm / 28 × 25 mm · figure 1 · 14 cm	1
23.25.07	LANGENBECK-KOCHER Retractor · 15 × 40 mm · 21 cm	1
24.22.13	WEITLANER Retractor · 3 × 4 teeth sharp · 13 cm	1
24.26.13	WEITLANER-WULLSTEIN Self-retaining retractors · sharp · 13 cm	1
26.42.58	Raspator · 8 mm · 17 cm	1
27.04.20	HAJEK Mallet · Ø 26 mm / 200 g · 21 cm	1



Spongiosaentnahme aus dem Beckenkamm
Removal of Spongiosa from the Iliac Crest
Extracción de sustancia esponjosa de la cresta iliaca
Prélèvement d'os spongieux sur la crête iliaque
Prelievo di spongiosa dalla cresta iliaca

D08

“CRISTACA”



PART 2

Item number	Description	Quantity
28.62.26P	Iliac crest craft gouge with stop · 6 mm · 18 cm	1
29.51.60	Iliac crest curette with stop · 7 mm · figure 1 · 17 cm	1
46.35.22	Burr rack · for 6 burrs up to 50 mm length · empty · 90 × 62 × 22 mm	1
47.30.08	Bowl · Ø 80 mm · height 35 mm · 100 ml	1
47.31.02	Bowl · Ø 60 mm · height 30 mm · 60 ml	1
47.50.60	Mixing cup with lid · Ø 37 mm · height 30 mm · 50 ml	1
63.45.11	Surgical hand piece · with irrigation tube · 11 cm	1
63.90.70	Trephine · Ø 7 mm · shaft Ø 2.35 mm · standard shank end · 44 mm	2
63.90.80	Trephine · Ø 10 mm · shaft Ø 2.35 mm · standard shank end · 44 mm	2
68.82.75	Bone mill with assembling wrench · Ø 68 mm · 11 cm	1
88.00.25	Bipolar connecting cable · coaxial connector Ø 12.5 mm · US-standard · 4 m	1
88.00.40	Bracket · for high frequency cable · 22.5 cm	1
88.07.08	Bipolar non-sticking forceps · 1.0 mm · 18 cm	1
204.33.18	METZENBAUM Dissecting scissors · supercut · curved · 18 cm	1
49.97.02	Wire baskets · 240 × 255 × 50 mm	2
49.50.15	Mediccontainer · 290 × 290 × 150 mm · silver	1



D08

Spongiosaentnahme aus dem Beckenkamm
Removal of Spongiosa from the Iliac Crest
Extracción de sustancia esponjosa de la cresta iliaca
Prélèvement d'os spongieux sur la crête iliaque
Prelievo di spongiosa dalla cresta iliaca

“SHEPARD”



PART 1

Item number	Description	Quantity
01.22.10	Scalpel blade · figure 10 · sterile · packing unit 100 pieces	1
01.22.11	Scalpel blade · figure 11 · sterile · packing unit 100 pieces	1
01.27.03	Scalpel handle · no 3 · standard · 12.5 cm	1
01.27.07	Scalpel handle · no 7 · long · 16.5 cm	1
03.10.15	MIXTER Scissors · straight · 15.5 cm	1
06.21.15	ADSON Tissue forceps · 15 cm · 1 x 2 teeth · smooth	1
06.22.15	MICRO-ADSON Dressing forceps · serrated · 15 cm	1
09.83.30	FRAZIER (FERGUSSON) Suction cannula · 10 French · angled · 12.5 cm	1
10.20.65	CRILE-WOOD “HM” (DEBAKEY “HM”) Needle holder · fine · 15 cm	1
15.44.12	HALSTED-MOSQUITO Forceps · straight · 12.5 cm	2
19.16.20	GROSS Dressing forceps · straight · 20 cm	1
22.16.14	ROUX Retractor · figure 1 · 14 cm	1
24.22.13	WEITLANER Retractor · 3 x 4 teeth sharp · 13 cm	1
26.42.58	Raspatory · 8 mm · 17 cm	1
27.06.20	Mallet metal · with nylon facings · 200 g · 18.5 cm	1
27.57.06P	MINI-LAMBOTTE Osteotome · 6 mm · 13 cm	1
→ 27.57.08P	MINI-LAMBOTTE Osteotome · 8 mm · 13 cm	1
→ 27.57.10P	MINI-LAMBOTTE Osteotome · 10 mm · 13 cm	1
28.62.06	MINI-LEXER Gouge · 6 mm · 18 cm	1



Instrumente, optional
 Instruments optional
 Instrumentos opcional
 Instruments optionnel
 Strumenti opzionale



Spongiosaentnahme aus dem Beckenkamm
Removal of Spongiosa from the Iliac Crest
Extracción de sustancia esponjosa de la cresta iliaca
Prélèvement d'os spongieux sur la crête iliaque
Prelievo di spongiosa dalla cresta iliaca

D08

“SHEPARD”

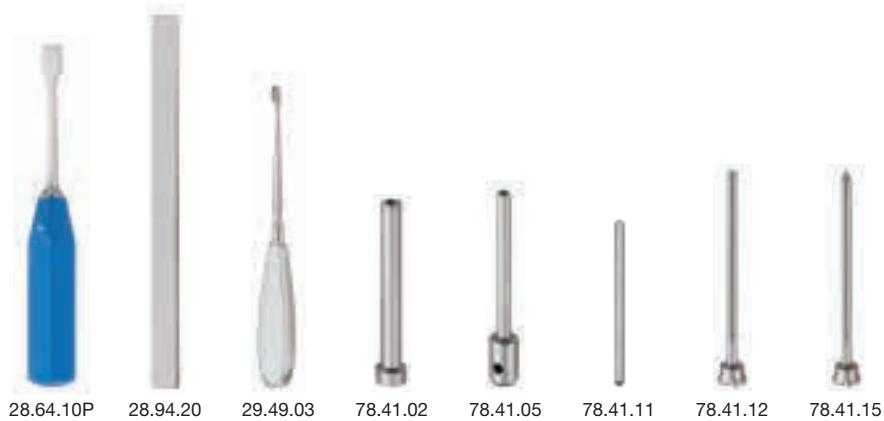

28.64.10P 28.94.20 29.49.03 78.41.02 78.41.05 78.41.11 78.41.12 78.41.15



204.33.18



49.50.15



49.97.02

PART 2

Item number	Description	Quantity
28.64.10P	LEXER Chisel · 10 mm · 22 cm	1
→ 28.64.20P	LEXER Chisel · 20 mm · 22 cm	1
→ 28.64.30P	LEXER Chisel · 30 mm · 22 cm	1
28.94.20	LAMBOTTE Osteotome · straight · 20 mm · 24 cm	1
→ 28.94.30	LAMBOTTE Osteotome · straight · 30 mm · 24 cm	1
29.49.03	Sharp curette · oval · 3 mm · 18.0 cm	1
78.41.02	SHEPARD Cortical cutter · only	1
78.41.05	SHEPARD Cylinder osteotome · Ø 5 mm · only	1
→ 78.41.06	SHEPARD Cylinder osteotome · Ø 6 mm · only	1
→ 78.41.08	SHEPARD Cylinder osteotome · Ø 8 mm · only	1
78.41.11	SHEPARD Cross pin · only	1
78.41.12	SHEPARD Ram · Ø 5 mm	1
→ 78.41.13	SHEPARD Ram · Ø 6 mm	1
→ 78.41.14	SHEPARD Ram · Ø 8 mm	1
78.41.15	SHEPARD Trocar · Ø 5 mm	1
→ 78.41.16	SHEPARD Trocar · Ø 6 mm	1
→ 78.41.18	SHEPARD Trocar · Ø 8 mm	1
204.33.18	METZENBAUM Scissors · supercut · curved · 18 cm	1
49.50.15	Medicontainer · 290 x 290 x 150 mm · silver	1
49.97.02	Wire basket · 240 x 255 x 50 mm	2

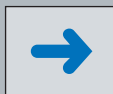

Instrumente, optional
 Instruments optional
 Instrumentos opcional
 Instruments optionnel
 Strumenti opzionale



Frakturbehandlung
Fracture Treatment
Tratamiento de fracturas
Traitement des fractures
Trattamento di frattura

D09



01.22.10 01.27.03 01.27.07 02.41.12 03.07.14 03.57.86 04.51.15 06.01.14 06.05.14 06.06.18 06.20.62
 06.21.12 06.31.15 06.52.15 07.30.16 09.79.85 09.83.30 10.20.64 11.20.67 11.34.68 14.26.10 15.40.12

PART 1		
Item number	Description	Quantity
01.22.10	Scalpel blade · figure 10 · sterile · packing unit 10 pieces	1
01.27.03	Scalpel handle · no 3 · standard · 12.5 cm	1
01.27.07	Scalpel handle · no 7 · long · 16.5 cm	1
02.41.12	Dissecting scissors · curved · 12 cm	1
03.07.14	Operating scissors · curved · sharp / blunt · 14.5 cm	1
03.57.86	LEXER Scissors · curved · 16 cm	1
04.51.15	JOSEPH Scissors · curved · 15 cm	1
06.01.14	Dressing forceps · medium · 14.5 cm	1
06.05.14	Tissue forceps · 1 × 2 teeth · standard · 14.5 cm	1
06.06.18	Tissue forceps · 1 × 2 teeth · medium · 18.0 cm	2
06.20.62	ADSON "HM" Dressing forceps · 12 cm	1
06.21.12	ADSON Tissue forceps · 1 × 2 teeth · smooth · 12 cm	1
06.31.15	SEMKEN Tissue forceps · straight · 1 × 2 teeth · 15 cm	1
06.52.15	DEBAKEY AT Vascular forceps · 2.0 mm · 15 cm	1
07.30.16	GRUENWALD Forceps · serrated · 16 cm	1
09.79.85	Infusion cannula · with olive · 1.8 × 80 mm · curved · Luer	1
09.83.30	FRAZIER (FERGUSSON) Suction cannula · 10 French · angled · 12.5 cm	1
10.20.64	BABY-CRILE-WOOD "HM" Needle holder · 15 cm	1
11.20.67	MATHIEU "HM" Needle holder · 16 cm	1
11.34.68	TOENNIS "HM" Needle holder · 18 cm	1
14.26.10	BEEBEE Scissors · straight · sharp/sharp · 10.5 cm	1
15.40.12	MICRO-HALSTED Hemostatic forceps · straight · 12.5 cm	2





PART 2

Item number	Description	Quantity
15.41.12	MICRO-HALSTED Hemostatic forceps · curved · 12.5 cm	2
15.46.12	HALSTED-MOSQUITO Forceps · straight · 1 × 2 teeth · 12.5 cm	2
16.06.14	PEAN Hemostatic forceps · short jaws · 14 cm	4
16.10.13	PEAN Hemostatic forceps · straight · 13 cm	2
17.55.10	BACKHAUS Towel clamp · 10.5 cm	6
19.17.20	GROSS Dressing forceps · curved · 20 cm	1
20.15.13	KOENIG Retractor · 13 × 10 mm · 17 cm	1
20.30.20	GILLIES Hook · large · 19 cm	2
20.50.01	JOSEPH Nasal hook · 1 teeth · 16 cm	2
20.53.42	Retractor · 2 teeth · 6 × 12 mm · 16 cm	2
20.64.01	Tracheal retractor · 1 tooth · sharp · 16 cm	1
22.00.06	Spatula · malleable · 6 × 200 mm	1
→ 22.00.12	Spatula · malleable · 12 × 200 mm	1
→ 22.00.17	Spatula · malleable · 17 × 200 mm	1
22.30.03	VOLKMANN Retractor · 3 teeth · sharp · 13 mm · 21 cm	2
22.34.01	VOLKMANN Retractor · 1 tooth · sharp · 22 cm	1
23.33.12	MIDDELDORPF Retractor 22 × 20 mm · 22.5 cm	1
26.42.05	WILLIGER Raspatory · 5 mm · 16 cm	1
26.60.35	LANGENBECK Raspatory · 15 mm · 19 cm	1
29.83.72	JANSEN Sharp curette · double-ended · 3 / 4 mm · 17 cm	1
35.15.19	DINGMAN Bone holding forceps · 19 cm	1
35.24.20	SEMB Bone holding clamp · without catch · 20 cm	1

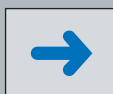

Instrumente, optional
Instruments optional
Instrumentos opcional
Instruments optionnel
Strumenti opzionale



**Frakturbehandlung
Fracture Treatment
Tratamiento de fracturas
Traitement des fractures
Trattamento di frattura**

D09



PART 3

Item number	Description	Quantity
44.90.70	GUBISCH Penholder · 13 cm	1
44.90.72	Feather · no 46 · for marking · packing unit 10 pieces	1
47.20.25	Kidney basin · 250 × 125 × 35 mm	1
47.31.04	Round bowl · Ø 80 mm · height 40 mm · 160 ml	1
→ 47.31.06	Round bowl · Ø 110 mm · height 55 mm · 400 ml	1
60.34.21	BOWMAN (WILLIAMS) Lacrymal probe · figure 00/0 nickel silver · 13 cm	1
66.08.03	KILLIAN Nasal speculum · figure 1 · 35 mm · 14 cm	1
68.01.05	OBWEGESER Retractor · 16 × 80 mm · 22 cm	1
68.01.25	OBWEGESER Ramus retractor · 11 × 70 mm · 22 cm	1
68.01.44	OBWEGESER Soft tissue retractor · down · 10 × 42 mm	1
→ 68.01.46	OBWEGESER Soft tissue retractor · down · 14 × 70 mm	1
68.01.80	OBWEGESER Mandibular channel retractor · 8 mm · 17.5 cm	1
→ 68.01.81	OBWEGESER Mandibular channel retractor · 10 mm · 17.5 cm	1
68.02.00	HOURIGAN Raspatory · round/pointed · 17.5 cm	1
68.02.02	OBWEGESER Raspatory · 7 mm · 17.5 cm	1
→ 68.02.03	OBWEGESER Raspatory · 9 mm · 17.5 cm	1
68.02.12	OBWEGESER Raspatory · curved · 7 mm · 20 cm	1
68.02.21	OBWEGESER-FREER Raspatory · double ended · 21 cm	1
68.04.05	OBWEGESER Mandibular awl · 14 cm	1
68.04.10	OBWEGESER Awl · for zygomatic arch · 23 cm	1
68.04.15	OBWEGESER Maxillary awl · 18 cm	1
68.04.73	OBWEGESER "HM" Wire twister · 13 cm	1
68.05.20	WANGERIN Mandibular ramus positioning instrument · 18 cm	1



Instrumente, optional
Instruments optional
Instrumentos opcional
Instruments optionnel
Strumenti opzionale



68.15.50 68.18.92 68.25.89 72.00.52 72.00.56 72.05.63 77.10.10 88.00.20 88.00.40 88.17.08



202.21.61 204.33.14 330.01.85 331.11.04 331.50.20 332.10.20 335.01.91 390.70.20 49.60.17 49.97.21

PART 4

Item number	Description	Quantity
68.15.50	MERESHON Band pusher · 14.5 cm	1
68.18.92	DOCKHORN Cheek retractor · 40 × 12 mm · 21 cm	2
68.25.89	STEINHAUSER Mandibular reduction clamp · 17.5 cm	2
72.00.52	HANNA Tongue spatula · 20 cm	1
72.00.56	CLAUDINHA Tongue spatula · 21 cm	1
72.05.63	DENHART-HOEFERT Mouth gag · 12.5 cm	1
77.10.10	DINGMAN Bone hook · 10 mm · 19 cm	1
88.00.20	Bipolar cable · Ø 12.5 mm · 3 m	1
88.00.40	Bracket · for high frequency cable · 22.5 cm	1
88.17.06	Bipolar forceps · straight · blunt · 16.5 cm	1
202.21.61	Iris Scissors · supercut plus · curved · 11.5 cm	1
204.33.14	METZENBAUM Scissors · supercut · curved · 14 cm	1
330.01.85	LUNIATSCHEK Gauze packers · blunt · 18 cm	1
331.11.04	Mouth mirror · magnifying · figure 4 · packing unit 12 pieces	1
331.50.20	Mouth mirror handle	1
332.10.20	LONDON-COLLEGE Dental plier · serrated · 15 cm	1
335.01.91	Dental explorer · figure 9a · 15 cm	1
390.70.20	Universal pin bending plier · 16 cm	1
49.60.17	Medicontainer · 590 × 290 × 170 mm · silver	1
49.97.21	Wire basket · 510 × 255 × 50 mm	3



**Orbitarekonstruktion
Orbital Reconstruction
Reconstrucción orbitaria
Reconstruction orbitale
Ricostruzione dell'orbita**

D10

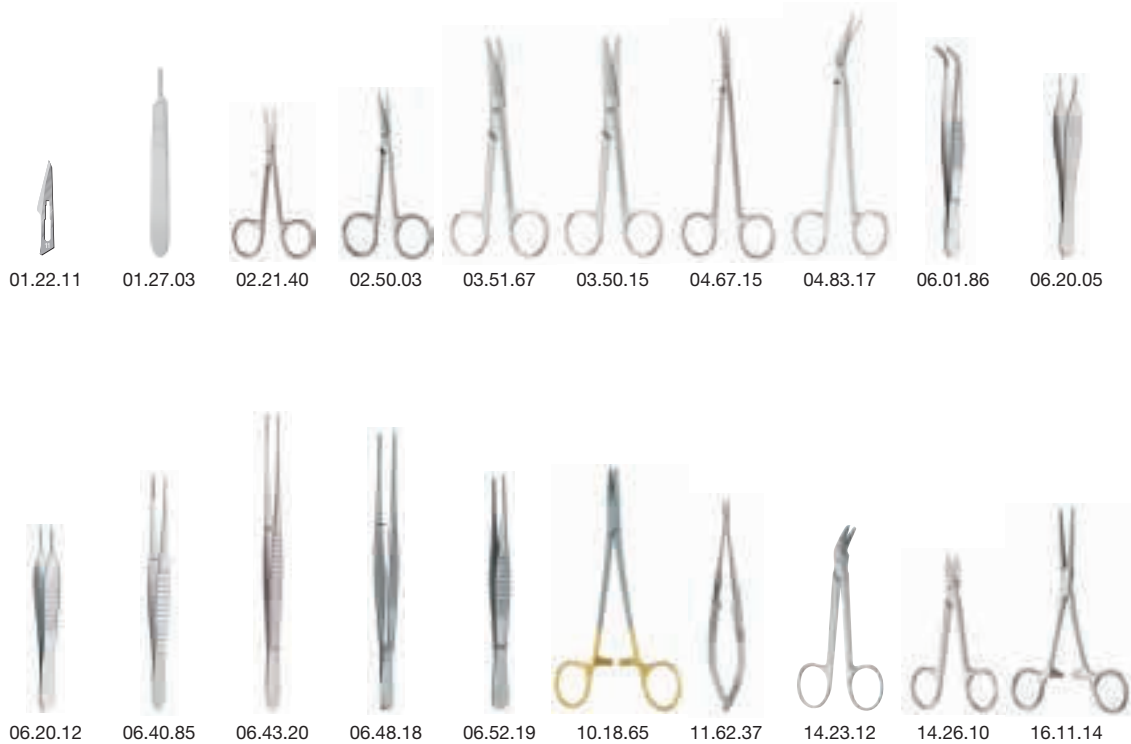

PART 1

Item number	Description	Quantity
→ 01.22.10	Scalpel blade · figure 10 · sterile · packing unit 100 pieces	1
01.22.11	Scalpel blade · figure 11 · sterile · packing unit 100 pieces	1
→ 01.22.12	Scalpel blade · figure 12 · sterile · packing unit 100 pieces	1
01.27.03	Scalpel handle · no 3 · standard · 12.5 cm	1
02.21.40	IRIS SELECT scissors · curved · 10.5 cm	1
02.50.03	STEVENS scissors · curved · sharp · 11.5 cm	1
03.50.15	MAYO scissors · straight · 15 cm	1
03.51.67	MAYO "HM" scissors · curved · 17 cm	1
04.67.15	Dissecting scissors · curved · semi-blunt · 15 cm	1
04.83.17	LOCKLIN Scissors · one blade serrated · 16 cm	1
06.01.86	Dressing forceps · curved · medium with · 16 cm	1
06.20.05	HUDSON-EWALD Tissue forcep · 1 × 2 teeth · 12 cm	2
06.20.12	ADSON Dressing forceps · serrated · 12 cm	2
06.40.85	GILLIES Tissue forceps · 1 × 2 teeth · 15 cm	1
06.43.20	WAUGH Tissue forceps · 1 × 2 teeth · cross threads · 20 cm	1
06.48.18	POTTS-SMITH Tissue forceps · 1 × 2 teeth · 18 cm	1
06.52.19	DEBAKEY AT Dressing forceps · 2.0 mm · 20 cm	1
10.18.65	MAYO-HEGAR "HM" Needle holder · straight · cross threads · 15 cm	1
11.62.37	CASTROVIEJO Needle holder · straight · cross threads · 17 cm	1
14.23.12	UNIVERSAL Wire cutting scissors · one blade serrated · 12 cm	1
14.26.10	BEEBEE Wire cutting scissors · straight · sharp · one blade serrated · 10.5 cm	1
16.11.14	PEAN AT Hemostatic forceps · curved · 14 cm	1



Instrumente, optional
Instruments optional
Instrumentos opcional
Instruments optionnel
Strumenti opzionale



Item number	Description	Quantity
16.12.14	KOCHER AT Intestinal clamp · straight · 1 × 2 teeth · 14 cm	1
17.54.10	TOHOKU Towel clamp · curved · cross threads · 10 cm	1
19.17.20	GROSS Dressing forceps · curved · 20 cm	1
20.05.09	SENN-MILLER Delicate retractor · double-ended · blunt	1
20.20.57	Delicate Retractor · 7 mm · blunt · 16 cm	1
20.65.01	Delicate Retractor · 9 mm · blunt · 1 tooth · 16 cm	1
22.00.12	Spatula · malleable · 12 × 200 mm	1
→ 22.00.17	Spatula · malleable · 17 × 200 mm	1
→ 22.00.25	Spatula · malleable · 25 × 200 mm	1
22.34.01	VOLKMANN Retractor · sharp · curved · 22 cm	1
26.24.04	WILLIGER Elevator · 4 mm · blunt · 17 cm	1
26.42.07	WILLIGER Raspatory · 7 mm · sharp · 16 cm	1
26.42.14	KAHRE-WILLIGER Raspatory · 4 mm · sharp · 16 cm	1
26.42.56	Raspatory · 6 mm · sharp · curved · 17 cm	1
26.64.13P	Raspatory · 3 mm · sharp · curved · 18.5 cm	1
47.30.08	Round bowl · Ø 80 mm · height 35 mm · 100 ml	1
60.34.88	ZIEGLER Lacrymal probe · 11 cm	2
62.21.42	WULLSTEIN Suction tube · Ø 2.0 mm · sterling silver · malleable · Luer · 14 cm	2
62.21.46	WULLSTEIN Suction handle · Luer	2
67.21.15	COTTLE Nasal retractor · 14 cm	1
68.02.02	OBWEGESER Raspatory · 7 mm · sharp · 17.5 cm	1
68.02.22	OBWEGESER-FREER Raspatory · sharp/blunt · 20.5 cm	1





D10

Orbitarekonstruktion Orbital Reconstruction Reconstrucción orbitaria Reconstruction orbitale Ricostruzione dell'orbita



68.82.31



88.00.20



88.20.06



88.70.06



330.01.80



49.60.15



49.97.12

PART 3

Item number	Description	Quantity
68.82.31	KLUBA Orbital hook · small · 19 cm	1
→ 68.82.32	KLUBA Orbital hook · medium · 19 cm	1
→ 68.82.33	KLUBA Orbital hook · large · 19 cm	1
88.00.20	Bipolar cable · Ø 12.5 mm · 3 m	1
88.20.06	Bipolar forceps · straight · blunt · 20 cm	1
88.70.06	Bipolar forceps · bayonet · straight · 19 cm	1
330.01.80	LUNIATSCHEK Gauze packer · sharp · 18cm	1
→ 330.01.85	LUNIATSCHEK Gauze packer · blunt · 18cm	1
49.60.15	Medicontainer · 590 × 290 × 150 mm · silver	1
49.97.12	Wire basket · 480 × 255 × 50 mm	2

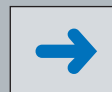



PART 1		Item number	Description	Quantity
		01.22.10	Scalpel blade · figure 10 · sterile · packing unit 100 pieces	1
		01.22.11	Scalpel blade · figure 11 · sterile · packing unit 100 pieces	1
		01.27.03	Scalpel handle · no 3 · standard · 12.5 cm	2
		01.27.13	Scalpel handle · no 3L · standard · 12.5 cm	1
		03.51.64	MAYO "HM" Scissors · curved · 14 cm	1
		04.21.14	BROPHY (SULLIVAN) Scissors · curved · 14 cm	1
		06.01.16	Dressing forceps · medium · 16 cm	1
		06.22.12	MICRO-ADSON Dressing forceps · serrated · 12 cm	1
		→ 06.22.15	MICRO-ADSON Dressing forceps · serrated · 15 cm	1
		06.23.12	MICRO-ADSON Tissue forceps · 1 × 2 teeth · 12 cm	2
		06.25.12	ADSON-BROWN Tissue forceps · straight · 7 × 7 teeth · 12 cm	1
		06.40.85	GILLIES Tissue forceps · 1 × 2 teeth · 15 cm	2
		06.52.15	DEBAKEY AT Vascular forceps · 2 mm · 15 cm	1
		06.60.92	GERALD Tissue forceps · straight · 1 × 2 teeth · 18 cm	2
		07.10.15	BROWN Grasping forceps · 15 cm	1
		09.08.14	Myrtle leaf probe · 14.5 cm	2
		09.79.76	Infusion cannula · with olive · 2.0 × 80 mm	2
		09.83.30	FRAZIER (FERGUSSON) Suction cannula · 10 French · angled · 12.5 cm	1
		10.20.65	CRILE-WOOD "HM" (DEBAKEY "HM") Needle holder · fine · 15 cm	2
		→ 10.20.68	CRILE-WOOD "HM" (DEBAKEY "HM") Needle holder · fine · 18 cm	1
		11.18.70	MATHIEU-KOCHER "HM" Needle holder · 20 cm	1
		11.34.68	TOENNIS "HM" Needle holder · 18 cm	1



Instrumente, optional
Instruments optional
Instrumentos opcional
Instruments optionnel
Strumenti opzionale



Weichteilbehandlung
Soft Tissue Therapy
Tratamiento de tejido blando
Traitement des parties molles
Trattamento dei tessuti molli

D11

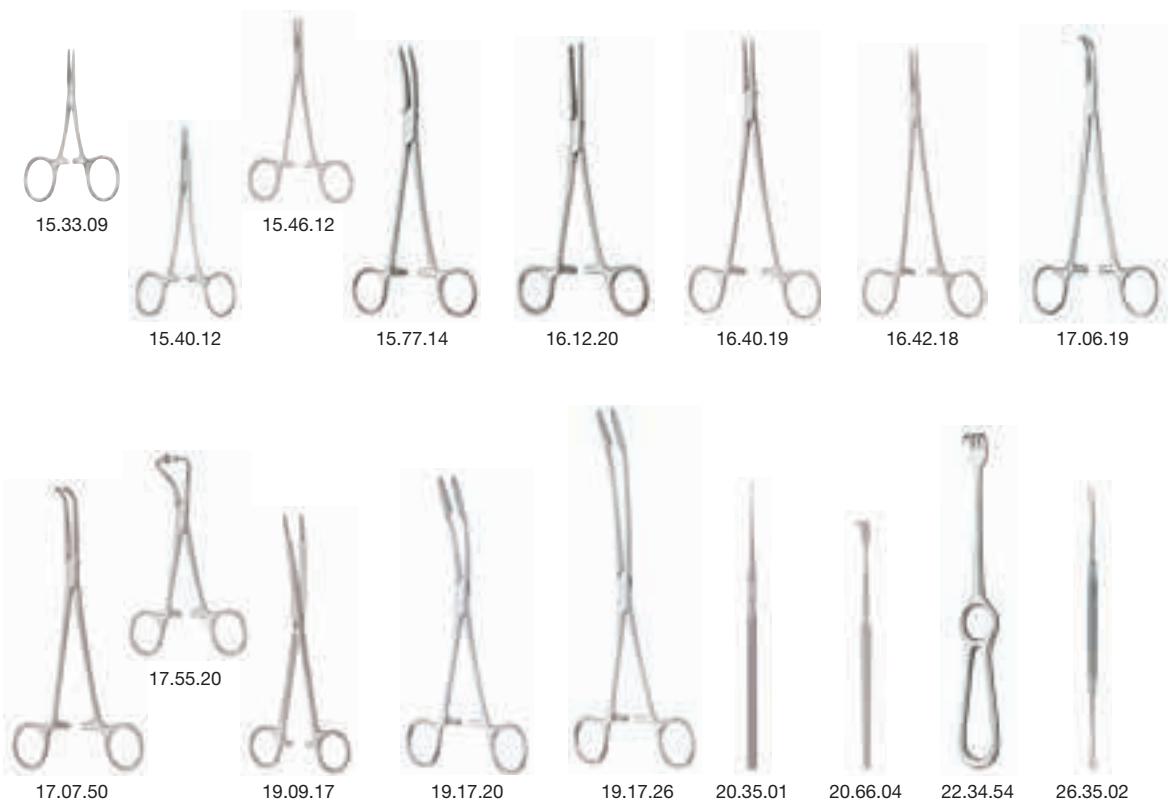

PART 2

Item number	Description	Quantity
15.33.09	HARTMANN (BABY MOSQUITO) Hemostatic forceps · curved · 10 cm	2
15.40.12	MICRO-HALSTED Hemostatic forceps · straight · 12.5 cm	6
→ 15.41.12	MICRO-HALSTED Hemostatic forceps · curved · 12.5 cm	6
15.46.12	HALSTED-MOSQUITO Forceps · straight · 1 × 2 teeth · 12.5 cm	6
15.77.14	SPENCER-WELLS Hemostatic forceps · curved · 14 cm	6
16.12.20	ROCHESTER-OCHSNER Hemostatic forceps · 1 × 2 teeth · straight · 20 cm	2
16.40.19	ADSON Hemostatic forceps · straight · 18.5 cm	2
16.42.18	HALSTED (ADSON) Hemostatic forceps · 1 × 2 teeth · straight · 18 cm	2
17.06.19	MIXTER-BABY Forceps · 19 cm	1
17.07.50	O'SHAUGNESSY Hemostatic forceps · curved · 20 cm	1
17.55.20	BACKHAUS Towel clamp · with ball · 11 cm	4
19.09.17	Dressing forceps · curved · delicate · 17.5 cm	1
19.17.20	GROSS Dressing forceps · curved · 20 cm	1
19.17.26	MAIER Dressing forceps · curved · 26 cm	2
20.35.01	BARSKY Skin hook · 1 tooth · 15 cm	2
20.66.04	Tracheal retractor · 4 teeth · sharp · 1 mm · 16 cm	2
22.34.54	VOLKMANN Retractor · 4 teeth · semisharp · 18 mm · 22 cm	2
26.35.02	FREER Periosteal elevator · sharp/blunt · 5.0 mm · 19 cm	1





PART 3		
Item number	Description	Quantity
26.40.06	KOENIG Raspatory · 5 mm · 15 cm	2
26.42.05	WILLINGER Raspatory · 5 mm · 16 cm	1
26.48.04	ADSON Raspatory · 6 mm · straight · sharp · 17 cm	1
26.64.26P	Raspatory · 6 mm · 18.5 cm	1
29.48.03	SHARP Curette · round · Ø 3 mm · 17 cm	1
29.83.62	WILLIGER Sharp curette · double-ended · angled · 14 cm	1
29.83.72	JANSEN Sharp curette · double-ended · 3/4 mm · 17 cm	1
30.71.03	BEYER Bone rongeur · 3 mm · curved · 17 cm	1
44.37.15	Rule · stainless steel · 15 cm	1
46.37.50	Needle case · Ø 65 mm	1
47.20.25	Kidney basin · 250 × 125 × 35 mm	1
52.46.50	MUSEUX Uterine tenaculum forceps · 2 × 2 teeth · 20 cm	1
57.31.59	OLIVECRONA Spatula · 7 + 9 mm · straight · 18 cm	1
→ 57.31.63	OLIVECRONA Spatula · 11 + 13 mm · straight · 18 cm	1
→ 57.31.68	OLIVECRONA Spatula · 15 + 18 mm · straight · 18 cm	1
→ 57.31.72	OLIVECRONA Spatula · 18 + 22 mm · straight · 18 cm	1
60.05.12	DESMARRES Lid retractor · 14 mm · figure 2 · 14 cm	2
60.34.22	BOWMAN (WILLIAMS) Lacrymal probe · figure 1/2 · 13 cm · nickel silver	2
68.01.41	OBWEGESER Soft tissue retractor · down · 5 × 18 mm	2
→ 68.01.42	OBWEGESER Soft tissue retractor · down · 7 × 25 mm	2
→ 68.01.43	OBWEGESER Soft tissue retractor · down · 10 × 35 mm	2
→ 68.01.44	OBWEGESER Soft tissue retractor · down · 10 × 42 mm	2
68.01.99	Vestibulum Retractor universal · 15 cm	1
68.02.22	OBWEGESER-FREER Elevator · double ended · 20.5 cm	1



Weichteilbehandlung
Soft Tissue Therapy
Tratamiento de tejido blando
Traitement des parties molles
Trattamento dei tessuti molli

D11

21
8
20
19
7
18
17
6
16
15
5
14
13
4
12
11
3
10
9
2
8
7
3
6
5
2
4
3
1
2
1
1
cm | inch



72.00.52 72.00.56 72.05.63 88.00.20 88.00.40 88.12.06 202.21.10 204.33.63 204.35.68 204.67.16
 330.01.85 330.10.03 331.50.10 332.10.22 335.01.91 49.60.17 49.97.21

PART 4

Item number	Description	Quantity
72.00.52	HANNA Tongue spatula · 20 cm	1
72.00.56	CLAUDINHA Tongue spatula · 21 cm	1
72.05.63	DENHART-HOEFERT Mouth gag · 12.5 cm	1
88.00.20	Bipolar cable · Ø 12.5 mm · 3 mm	1
88.00.40	Bracket · for high frequency cable · 22.5 cm	1
88.12.06	Bipolar forceps straight · blunt · 11 cm	2
202.21.10	Iris scissors · supercut · straight · 10.5 cm	2
204.33.63	METZENBAUM Scissors · supercut plus · curved · 14 cm	1
204.35.68	METZENBAUM-SLIM Scissors · supercut plus · curved · 18 cm	1
204.67.16	REYNOLDS (JAMESON) Scissors · supercut · curved · 16 cm	1
330.01.85	LUNIATSCHEK Gauze packers · blunt · 3 mm · 18 cm	1
→330.01.86	LUNIATSCHEK Gauze packers · sharp · 2 mm · 18 cm	1
331.10.03	Mouth mirror · plane · figure 3 · packing unit 12 pieces	1
331.50.10	Mouth mirror handle	2
332.10.22	LONDON-COLLEGE Dental plier · 15 cm	1
335.01.91	Dental explorer · figure 9a · 15 cm	1
49.60.17	Medicontainer · 590 × 290 × 170 mm · silver	1
49.97.21	Wire basket · 510 × 255 × 50 mm	3

Instrumente, optional
 Instruments optional
 Instrumentos opcional
 Instruments optionnel
 Strumenti opzionale

Unser komplettes MEDICONTAINER-Programm finden Sie in unserem Sonderprospekt.

For our complete MEDICONTAINER program please ask for our special brochure.

Nuestro programa completo de MEDICONTAINER se encuentra en nuestro folleto especial.

Vous trouverez notre programme complet des MEDICONTAINER dans notre prospectus spécial.

Il nostro programma completo di MEDICONTAINER si trova nel catalogo speciale.

MEDICONTAINER CONTAINER System



MEDICON

instruments

OMF - SURGERY

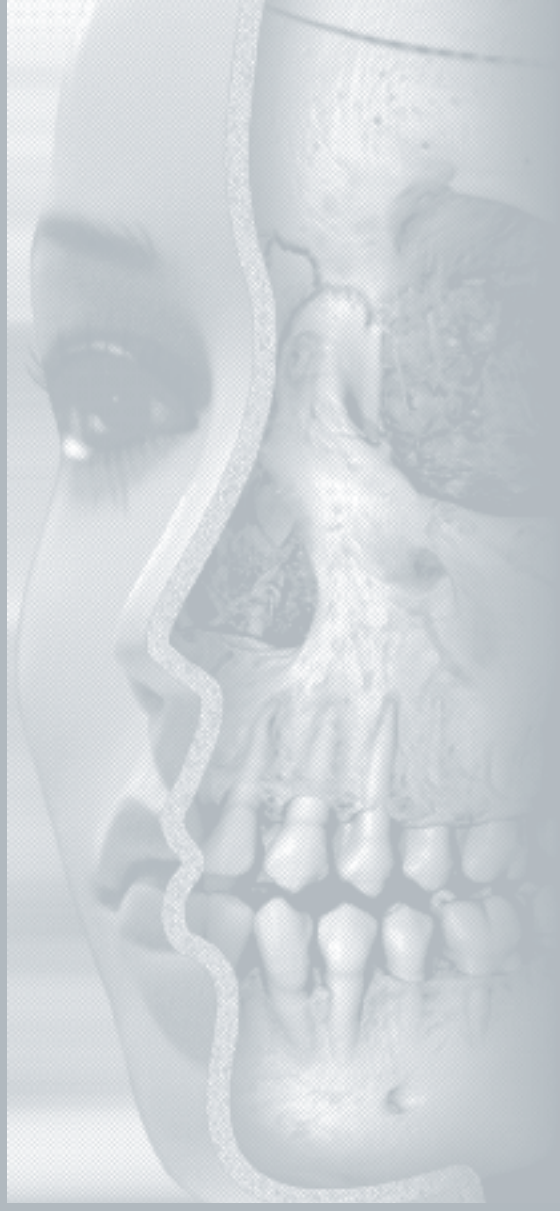



ALPHABETICAL INDEX



A	
Adaptationsinstrument	158
Adapter für PEN Saugkanülen	41
Adaptierungsklemmen	115
ADSON Anatomische Pinzette	22
ADSON-BABY Präparierklemmen	52
ADSON Elevatorium	104
ADSON HM Anatomische Pinzette	22
ADSON MICRO Anatomische Pinzette	22
ADSON Raspatorien	98-99
ADSON TOENNIS Präparierscheren	16
Ahlen	137
Alveolar-Haken	74
Anatomische Pinzetten	19-22, 54-55
Anmischbecher	151
Anschlusskabel	32
Antihalt-Pinzetten bipolar	27-32
Arterienklemmen	50-51
AUFRICHT GUBISCH Nasenhaken	85
AUFRICHT Nasenhaken	85
B	
BABY ADSON Präparierklemmen	52
BABY-CRILE-WOOD HM Nadelhalter	35
BABY-METZENBAUM Feine Präparierscheren	12
BABY-MOSQUITO HARTMANN Arterienklemmen	50
BACKHAUS Tüchklemmen	52-53
BACKHAUS-ROEDER Tüchklemmen	53
Bajonettpinzetten	26, 30-31
BARSKY Hauthäkchen	60
Beckenkamm-Hohlmeißel	150
Beckenkamminstrumente	150-152
Beckenkamm-Löffel	150
Beckenkamm-Retraktoren	152
BENICKE Feine Wundhaken	61
BENNET Elevatorium	103
BEUSE Feine Präparierscheren	11
BEYER Hohlmeißelzangen	122, 124
Bipolare Anschlusskabel	32
Bipolare Antihalt-Pinzetten	27-32
BLAKE Skalpellgriff	2, 141, 143
BLAKESLEY WEIL Nasenzangen	126-127
Blattosteotome	111
BLOCKSMA Häkchen	139
BLUME Osteotom	112
BLUMENTHAL Hohlmeißelzangen	121
Blutstillungsmeißel	128
Bohrerstände	151
BOWMAN Tränenkanalsonden	47
BOWMAN (WILLIAMS) Tränenkanalsonden	47
BROWN Gewebefasspinzetten	24

BRÜNINGS Flachmeißel	107
BRÜNINGS Zungenspatel	88
BUCHWALD Zungenspatel	88
Bulldog-Klemmen	49
C	
CASTROVIEJO-EPKER Zirkel	132
CASTROVIEJO Zirkel	132
CAWOOD UNIV. MINNESOTA Lippen- und Wangenhalter	87
Chirurgische Handstücke	131, 160-161
Chirurgische Pinzetten	20-23
Chirurgische Scheren	9-10
CINELLI Osteotome	112
CLAUDINHA Zungenspatel	96
COLLIN Wundhaken	78
COLLIN Zungenzangen	89
COTTLE Knochenheber	109
COTTLE Osteotom	109
COTTLE Spaltosteotom	109
COTTLE-MEDICON Osteotome	108
CRILE-WOOD BABY HM Nadelhalter	35
CRILE-WOOD HM Nadelhalter	35
CRILE-WOOD Nadelhalter	35
CUSHING HM Anatomische Pinzetten	21
CUSHING Nervhäkchen	58
CUSHING Pinzetten anatomisch/chirurgisch	20
CUSHING (TAYLOR) Bajonettpinzetten	26
CUSHING (TAYLOR) HM Bajonettpinzetten	26
CUSHING Venenhaken	59-60
D	
DANDY Arterienklemmen	50
DAUBENSPECK Scharfe Löffel	105
DEAN Tonsillenschere	10
DEBAKEY HM Nadelhalter	35
DENHART Mundsperrer	96
DENHART-HOEFERT Mundsperrer	96
DESMARRES Lidhalter	83
DIEFFENBACH Bulldog Klemme	49
DINGMAN Jochbogenelevatorium	104
DINGMAN Knochenhalte-zangen	118
DINGMAN Mundsperrer	95
DINGMAN Raspatorium	102
DINGMAN Zungendrucker	92, 95
DOCKHORN Wangenhalter	87
DOUGHTY KILNER Zungendrucker	90-93, 138
DOYEN Zungenspatel	88
Drahtbögen	133
Drahtrehklemme	135
Drähte	133
Drahtinstrumente	134-136

Drahtösenklemme	135
Drahtpositionierer	134
Drahtschere	135
Drahtschneidezangen	136

E

Einsätze für Winkelschraubendreher	163-164
Elevatorien	103-104, 139, 144
Elevatorium Jochbogen	104
EPKER CASTROVIEJO Zirkel	132
ERICH Drahtbögen	133
Extraorale Retraktoren	81

F

Fasszange	159
Feine Präparierscheren	8, 11-13
Feine Scheren	8
Feine Wundhaken	58-63
FERGUSSON-FRAZIER Saugkanüle	43
Fibula-Raspatorium	155
Flachmeißel	107
Flachzange	134
FOX Zahnfleischscheren	16
Fragment-Adaptierungsklemmen	115
Fräser	161
FRAZIER (FERGUSSON) Saugkanüle	43
FRAZIER Hauthäkchen	60
FRAZIER Saugkanülen	43
FREER Elevatorien	103
FREER OBWEGESER Elevatorium	103
FREER OBWEGESER Raspatorien	101
FREER Raspatorium	102
FREER-SCHEER Elevatorium	139
FROHN Watteträger	46

G

Gaumenspalten Raspatorien	139-140
Gaumenspalteninstrumente	138-140
GERALD Anatomische Pinzetten	21
Gewebefasspinzetten	24
GILLIES Chirurgische Pinzetten	23
GILLIES Elevatorium	104
GILLIES Feine Wundhaken	60
GILLIES HM Nadelhalter	36
GROSS Kornzangen	54-55
GUBISCH-AUFRIECHT Nasenhaken	85
GUTHRIE Feine Wundhaken	62

H

HAJEK Hammer	106
HAJEK-KOFLER Stanze	125
HAJEK Stanzen	125

Häkchen	58, 60, 139
Häkchen Haut	60
Häkchen Nerv	58
Haken Alveolar	74
Haken Mobilisation	116
Haken Nase	85
Haken Orbita	83
Haken Ramus	76
Haken Spina-nasalis	71
Haken Venen	59-60
Haken Weichteil	72-73
HAKIM Adaptationsinstrument	158
HAKIM Fasszange	159
HAKIM Fibula Raspatorium	155
HAKIM Intraoraler Retraktor	157
HAKIM OBWEGESER Raspatorien	158-159
HAKIM Plattenhaltezange	156
HAKIM Titan-Collumplatte	156
HALSTED-MOSQUITO Arterienklemmen	51
Halteklammer	32
Halter Lid	83
Halter Lippen	86-87
Halter Wangen	86-87
Hämmer	106
Handstücke	131, 160-161
HANNA Zungenspatel	96
HARALDSSON Saugelevatorium	44
HARTMANN (BABY-MOSQUITO) Arterienklemmen	50
HARTMANN Zungendrucker	91
Hauthäkchen	60
HEGAR-MAYO HM Nadelhalter	34
HM Drahtschneidezangen	136
HM Raspelaufsatz	169
HOEFERT DENHART Mundsperrerr	96
Hohlmeißel	150
Hohlmeißelzangen	121-124
Hohlsonden	46
HOSPITAL PROVIDENCE Arterienklemmen	50
HOURIGAN Raspatorien	99

I

Instrumente Beckenkamm	150-152
Instrumente Draht	134-136
Instrumente Gaumenspalten	138-140
Instrumente Lippen	138-140
Instrumente Sinuslifting	141-144
Interdentale Osteotome	108
Intraorale Retraktoren	81-82, 157

J

JAEGER Lidplatte	84
------------------	----



JANSEN ZAUFAL Hohlmeißelzange	124
Jochbogenelevatorium	104
JOSEPH Feine Präparierscheren	13
JOSEPH Feine Wundhaken	61
Juwelierpinzetten	25, 28-29
K	
Kabel Anschluss	32
KAHRE Raspatorium	140
KAHRE-WILLIGER Raspatorien	98
Kanülen Knopf	42
Kanülen Saug	39-44
Keilosteotome	111
KELLY Arterienklemmen	50
KELLY Feine Präparierscheren	13
KILNER-DOUGHTY Zungendrücker	90-93, 138
KILNER-RAGNELL Feine Präparierscheren	12
Kinnhalter	75
Klemme Drahtdreh	135
Klemme Drahtösen	135
Klemmen Adaptierung	115
Klemmen Arterien	50-51
Klemmen Bulldog	49
Klemmen Präparier	52
Klemmen Ramus	80
Klemmen Tuch	52-53
KLUBA Orbitahaken	83
KLUBA Spekulum	148
Knochenhaltezangen	118-119
Knochenhebel	109
Knochenmesszirkel	129, 131
Knochenmühlen	154
Knochensplitterzangen	120
Knochenspreizer	117
Knochenstopfer	128
Knopfkanülen	42
KOCHER LANGENBECK Wundhaken	70
KOCHER Wundhaken	64, 67
KOFLER HAJEK Stanze	125
KÖLN Mundsperrer	93-94
KÖLN Mundsperrer	138
Komprimierer	143
KÖNIG Raspatorium	97
Kornzangen	54
Kortikalisstanze	153
KRETSCHMER Halterungen	131
KRETSCHMER Referenz-Pin	130
KRETSCHMER Wundhaken	77
L	
LAMBOTTE MINI Osteotome	107
LAMBOTTE Osteotome	108

LANGENBECK Elevatorien	104
LANGENBECK Wundhaken	66
LANGENBECK-KOCHER Wundhaken	70
LANGENBECK PARKER (US ARMY) Wundhaken	78
Lidfasspinzette	24
Lidhalter	83
Lidplatte	84
LINDEMANN Fräser	161
Lineal Röntgen	129
Lineal Stahl	129, 131
Lippenhalter	86-87
Lippeninstrumente	138-140
LISTON RUSKIN Knochensplitterzangen	120
LOCKLIN Zahnfleischscheren	17
Löffel Beckenkamm	150
Löffel scharf	105
LUCAE Feine Wundhaken	58
LUER Hohlmeißelzangen	122
LUNIATSCHEK Drahtinstrumente	134
M	
MACDONALD Elevatorium	103
MAIER Kornzangen	54-55
MARCHAC Knochenspreizer	117
Markierungsinstrumente	130-131
MARQUARDT Hohlmeißelzange	124
MATHIEU HM Nadelhalter	37
Maxilla-Mobilisator	114
MAYO Präparierscheren	14
MAYO-HEGAR HM Nadelhalter	34
MAYO-STILLE Präparierscheren	14
MCINDOE Anatomische Pinzette	21
MCINDOE Knochensplitterzangen	120
MCINDOE Raspatorien	140
MCKESSON Mundkeile	89
MEAD Hammer	106
MEAD Hohlmeißelzangen	121
MEDICON COTTLE Osteotome	108
Meißel Blutstillung	128
Meißel flach	107
MERSHON Drahtpositionierer	134
Messinstrumente	129-132
Messzirkel	129, 131-132
METZENBAUM BABY Feine Präparierscheren	12
METZENBAUM-SLIM Präparierscheren	15
MICRO 2000 Nadelhalter	38
MICRO 2000 Pinzetten	25
MICRO-ADSON Anatomische Pinzette	22
MICRO-SLIM HM Nadelhalter	36
MIDDELDORPF Wundhaken	68-69

Mikro Nadelhalter	38
Mikro Pinzetten	25
Mikro-Sägen	165-171
Mikro-Sagittal-Säge	167
Mikro-Stichsäge	169
MILLER SENN Feine Wundhaken	61
MINI RUSKIN Hohlmeißelzangen	123
MINI-LAMBOTTE Osteotome	107
Mobilisator	114
Mobilisierhaken	116
Mod. USA Öhrsonden	45
MOLT Raspatorium	97
MÖLTGEN Winkelmesser	129
MORITZ-SCHMIDT Zungendrücker	91
MOSQUITO HALSTED Arterienklemme	51
MOSQUITO-BABY HARTMANN Arterienklemmen	50
Mucosa-Spanner	80
Mundkeile	89
Mundsperrer	93-96, 138
Myrtenblattsonden	45

N

Nadelhalter	33-38
Nadelhalter Mikro	38
Nasenhaken	85
Nasenraspeln	149
Nasenseptum-Osteotome	114
Nasenzangen	126-127
NELATON Hohlsonden	46
Nervhäkchen	58

O

OBWEGESER Ahlen	137
OBWEGESER Alveolar-Haken	74
OBWEGESER Beckenkamm-Retraktoren	152
OBWEGESER Blattosteotome	111
OBWEGESER Drahtösenklemme	135
OBWEGESER Fragment-Adaptierungsklemmen	115
OBWEGESER HM Drahtdrehklemme	135
OBWEGESER Interdentale Osteotome	108
OBWEGESER Keilosteotome	111
OBWEGESER Kinnhalter	75
OBWEGESER Knochenspreizer	117
OBWEGESER Maxilla-Mobilisator	114
OBWEGESER Nasenseptum-Osteotome	114
OBWEGESER Osteotome	108, 110-111, 113-114
OBWEGESER Progenie-Rinnen	75
OBWEGESER Ramus-Haken	76
OBWEGESER Ramus-Klemmen	80

OBWEGESER Raspatorien	99-102
OBWEGESER Spaltosteotome	110
OBWEGESER Spina-nasalis-Haken	71
OBWEGESER Tuber-Osteotome	113
OBWEGESER Unterkieferrand-Haken	74
OBWEGESER Weichteilhaken	72-73
OBWEGESER-FREER Elevatorium	103
OBWEGESER-FREER Raspatorien	101
OBWEGESER-HAKIM Raspatorien	158-159
Öhrsonden	45
Orbitahaken	83
Osseoskalpell	168
Osteotome	107-114
Osteotome Blatt	111
Osteotome interdental	108
Osteotome Keil	111
Osteotome Nasenseptum	114
Osteotome Spalt	109-110
Osteotome Tuber	113
Osteotome Zylinder	153
Oszillierende Mikro-Säge	166

P

PARKER Wundhaken	78
PARKER-LANGENBECK (US ARMY) Wundhaken	78
PARTSCH Flachmeißel	107
PASSOW Blutstillungsmeißel	128
PEN Saugkanülen	39-41
Pinzetten anatomisch	19-22, 54-55
Pinzetten antihaft	27-32
Pinzetten bajonett	26, 30-31
Pinzetten bipolar	27-32
Pinzetten chirurgisch	20-23
Pinzetten Gewebefass	24
Pinzetten Mikro	25
Plattenhaltezange	156
Positionierer	115
POTTS-SMITH HM Anatomische Pinzetten	20
Präparierklemmen	52
Präparierscheren	14-16
Progenie-Rinnen	75
PROVIDENCE-HOSPITAL Arterienklemmen	50

R

RAGNELL (KILNER) Feine Präparierscheren	12
Ramus-Haken	76
Ramus-Klemmen	80
Raspatorien	97-102, 139-140, 143, 158-159
Raspatorien Gaumenspalten	139-140



Raspatorium Fibula	155
Raspeln Nase	149
Referenz-Pin	130
Repositionszangen	116
Retraktor Unterkieferrand	74
Retraktoren Beckenkamm	152
Retraktoren extraoral	81
Retraktoren intraoral	81-82
ROEDER BACKHAUS Tuchklemme	53
Röntgen-Messstab	129
ROUX Wundhaken	79
ROWE Repositionszangen	116
RUSKIN Hohlmeißelzangen	123-124
RUSKIN-LISTON Knochensplitterzangen	120
RUSKIN-MINI Hohlmeißelzangen	123
S	
SACHSE Mikro-Sagittal-Säge	167
SACHSE Mikro-Stichsäge	169
SACHSE Osseoskalpell	168
SACHSE Oszillierende Mikro-Säge	166
Sägeblätter	166-169
Saugelevatorium	44
Sauginstrumente	39-44
Saugkanülen	39-44
Scharfe Löffel	105
SCHEER FREER Elevatorium	139
Schere Draht	135
Scheren chirurgische	9-10
Scheren Fein	8
Scheren Präparier	14-16
Scheren Präparier fein	8, 11-13
Scheren Tonsillen	10
Scheren Zahnfleisch	16-17
SCHMIDT MORITZ Zungendrücker	91
SEMB Knochenhaltezange	119
SENN-MILLER Feine Wundhaken	61
SHEPARD Ausstoßer	153
SHEPARD Kortikalisstanze	153
SHEPARD Querstift	153
SHEPARD Trokare	153
SHEPARD Zylinder-Osteotome	153
SILVER Osteotome	109
Sinuslifting-Elevatorien	141-142
Sinuslifting-Instrumente	141-144
Skalpelle	2-4
Skalpellgriffe	2-4, 141, 143
Skalpellgriffe Mini	4
Skalpellklingen	2-4
Skalpellklingen Mini	4
SLIM METZENBAUM Präparierscheren	15
SLIM MICRO HM Nadelhalter	36

SMITH Knochenspreizer	117
SMITH POTTS HM Anatomische Pinzetten	20
Sonden	45-47
Sonden hohl	46
Sonden Myrtenblatt	45
Sonden Ohr	45
Sonden Tränenkanal	47
Spaltosteotome	109-110
Spatel Zunge	88, 96
Spekulum	148
Sperrer Mund	93-96, 138
Spina-nasalis-Haken	71
Spreizer Knochen	117
Spreizer Wund	84
Spülinstrumente	39-44
Stahllineale	129, 131
Stanzen	125
STEINHÄUSER Knochenhalte­zangen	119
STEINHÄUSER Mucosa-Spanner	80
STELLBRINK Hohlmeißelzangen	122
STERNBERG Lippen- und Wangenhalter	87
STILLE MAYO Präparierscheren	14
STILLER Komprimierer	143
STILLER Raspatorium	97, 141, 143
STILLER Saugkanüle	43, 141, 143
STILLER Sinuslifting-Elevatorien	141-142
T	
TAYLOR-CUSHING Bajonett­pinzetten	26
TAYLOR-CUSHING HM Bajonett­pinzetten	26
TESSIER Mobilisierhaken	116
TESSIER Osteotome	112
Titan-Collumplatte	156
TOBOLD Zungendrücker	91
TOENNIS-ADSON Präparierscheren	16
Tonsillenschere	10
Tränenkanalsonden	47
Trepone	151
TRIACA Weichteilhaken	72-73
Tuber-Osteotome	113
Tuchklemmen	52-53
U	
UNIV. MINNESOTA CAWOOD Lippen- und Wangenhalter	87
UNIVERSAL HM Drahtschere	135
Unterkieferrand-Retraktor	74
US-ARMY PARKER-LANGENBECK Wundhaken	78
V	
Venenhaken	59-60

Vestibulumhaken	86
VOLKMANN Scharfe Löffel	105
VOLKMANN Wundhaken	64-65
W	
WAGNER Feine Scheren	8
WALTER Lidfasspinzette	24
WANG Raspatorien	140
Wangenhalter	86-87
WANGERIN Positionierer	115
WASSMUND Wundhaken	67
Watteträger	46
Weichteilhaken	72-73
WEIL-BLAKESLEY Nasenzangen	126-127
WEITLANER-WULLSTEIN Wundspreizer	84
WIEDER Zungendrücker	92
WILLIAMS BOWMAN Tränenkanalsonden	47
WILLIGER KAHRE Raspatorien	98
WILLIGER Raspatorien	97
Winkelmesser	129
Winkelschraubendreher	162-164
WOOD CRILE BABY HM Nadelhalter	35
WOOD CRILE HM Nadelhalter	35
WOOD CRILE Nadelhalter	35
WULLSTEIN WEITLANER Wundspreizer	84
Wundhaken	58-79
Wundhaken doppelendig	78-79
Wundhaken fein	58-63
Wundspreizer	84
Y	
YOUNG Zungenzange	89
Z	
Zahnfleischscheren	16-17
Zange Flach	134
Zangen Drahtschneide	136
Zangen Hohlmeißel	121-124
Zangen Knochenhalte	118-119
Zangen Knochensplitter	120
Zangen Korn	54
Zangen Nasen	126-127
Zangen Reposition	116
Zangen Zunge	89
ZAUFAL-JANSEN Hohlmeißelzange	124
Zirkel	129, 131-132
Zungendrücker	90-93, 138
Zungenspatel	88, 96
Zungenzangen	89
Zylinder-Osteotome	153



A	
Adapter for PEN Suction cannulas	41
Adapting forceps	115
ADSON-BABY Dissecting forceps	52
ADSON Dressing forceps	22
ADSON Elevators	104
ADSON HM Dressing forceps	22
ADSON MICRO Dressing forceps	22
ADSON Raspatories	98-99
ADSON TOENNIS Dissecting scissors	16
Alveolar retractor	74
Angular screwdrivers	162-164
Applying instrument	158
Arch bars	133
AUFRICHT GUBISCH Nasal retractor	85
AUFRICHT Nasal retractor	85
Awls	137
B	
BABY ADSON Dissecting forceps	52
BABY-CRILE-WOOD HM Needle holders	35
BABY-METZENBAUM Delicate dissecting scissors	12
BABY-MOSQUITO HARTMANN Hemostatic forceps	50
BACKHAUS Towel clamps	52-53
BACKHAUS-ROEDER Towel clamp	53
BARSKY Skin hooks	60
Bayonet forceps	26, 30-31
BENICKE Delicate retractors	61
BENNET Elevators	103
BEUSE Delicate dissecting scissors	11
BEYER Bone rongeurs	122, 124
Bipolar connecting cables	32
Bipolar non-sticking forceps	27-32
Blade osteotomes	111
BLAKE Scalpel handle	2, 141, 143
BLAKESLEY WEIL Nasal forceps	126-127
BLOCKSMA Hooks	139
BLUME Osteotome	112
BLUMENTHAL Bone rongeurs	121
Bone cutting forceps	120
Bone holding forceps	118-119
Bone lever	109
Bone measuring dividers	129, 131
Bone mills	154
Bone rongeurs	121-124
Bone separators	117
Bone tampers	128
BOWMAN Lacrimal probes	47
BOWMAN (WILLIAMS) Lacrimal probes	47
Bracket	32

BROWN Tissue grasping forceps	24
BRUENINGS Chisels	107
BRUENINGS Tongue spatula	88
BUCHWALD Tongue spatula	88
Bulldog clamps	49
Burr rack	151
Burrs	161
C	
Cables connecting	32
Calipers	129, 131-132
Cannulas suction	39-44
Cannulas with olive	42
CASTROVIEJO Calipers	132
CASTROVIEJO-EPKER Calipers	132
CAWOOD UNIV. MINNESOTA Lip and cheek retractor	87
Channel retractors	75
Cheek retractors	86-87
Chin retractor	75
Chisels	107
Chisels hemostatic	128
CINELLI Osteotomes	112
Clamps Bulldog	49
Clamps ramus	80
Clamps towel	52-53
CLAUDINHA Tongue spatulas	96
Cleft palate instruments	138-140
Cleft palate raspatory	139-140
COLLIN Retractor	78
COLLIN Tongue seizing forceps	89
Compressor	143
Connecting cables	32
Cortical cutter	153
COTTLE Bone lever	109
COTTLE Osteotome	109
COTTLE Splitting osteotome	109
COTTLE-MEDICON Osteotomes	108
Cotton carriers	46
CRILE-WOOD BABY HM Needle holder	35
CRILE-WOOD HM Needle holders	35
CRILE-WOOD Needle holders	35
Curettes iliac crest	150
Curettes sharp	105
CUSHING (TAYLOR) Bayonet forceps	26
CUSHING (TAYLOR) HM Bayonet forceps	26
CUSHING Forceps, dressing/tissue	20
CUSHING HM Dressing forceps	21
CUSHING Nerve hooks	58
CUSHING Vein retractors	59-60
Cylinder osteotomes	153

D	
DANDY Hemostatic forceps	50
DAUBENSPECK Sharp curettes	105
DEAN Tonsil scissors	10
DEBAKEY HM Needle holders	35
Delicate dissecting scissors	8, 11-13
Delicate retractors	58-63
Delicate scissors	8
DENHART Mouth gag	96
DENHART-HOEFERT Mouth gag	96
DESMARRES Lid retractors	83
DIEFFENBACH Bulldog clamps	49
DINGMAN Bone holding forceps	118
DINGMAN Mouth gag	95
DINGMAN Raspatory	102
DINGMAN Tongue depressors	92, 95
DINGMAN Zygoma elevator	104
Directors	46
Dissecting forceps	52
Dissecting scissors	14-16
DOCKHORN Cheek retractors	87
DOUGHTY KILNER Tongue depressors	90-93, 138
DOYEN Tongue spatulas	88
Dressing forceps	19-22, 54-55
E	
Elevator zygoma	104
Elevators	103-104, 139, 144
EPKER CASTROVIEJO Calipers	132
ERICH Arch bars	133
Extra oral retractors	81
F	
FERGUSSON-FRAZIER Suction cannulas	43
Fibula raspatory	155
Flat nose plier	134
Flexometer	129
Forceps adapting	115
Forceps bayonet	26, 30-31
Forceps bipolar	27-32
Forceps bone cutting	120
Forceps bone holding	118-119
Forceps dissecting	52
Forceps dressing	19-22, 54-55
Forceps hemostatic	50-51
Forceps Micro	25
Forceps nasal	126-127
Forceps non-sticking	27-32
Forceps reposition	116
Forceps tissue	20-23
Forceps tissue grasping	24
Forceps tongue seizing	89

Forceps wire loop	135
FOX Gum scissors	16
Fragment adapting forceps	115
FRAZIER (FERGUSSON) Suction cannulas	43
FRAZIER Skin hook	60
FRAZIER Suction cannulas	43
FREER Elevators	103
FREER OBWEGESER Elevator	103
FREER OBWEGESER Raspatories	101
FREER Raspatory	102
FREER-SCHEER Elevator	139
FROHN Cotton carriers	46
G	
Gags mouth	93-96, 138
GERALD Dressing forceps	21
GILLIES Delicate retractors	60
GILLIES Elevator	104
GILLIES HM Needle holder	36
GILLIES Tissue forceps	23
Gouge	150
Grasping forceps	159
GROSS Dressing forceps	54-55
GUBISCH-AUFRIEHT Nasal retractor	85
Gum scissors	16-17
GUTHRIE Delicate retractors	62
H	
HAJEK Mallet	106
HAJEK Rongeurs	125
HAJEK-KOFLER Rongeur	125
HAKIM Applying instrument	158
HAKIM Fibula raspatory	155
HAKIM Grasping forceps	159
HAKIM Intra oral retractor	157
HAKIM OBWEGESER Raspatories	158-159
HAKIM Plate holding forceps	156
HAKIM Titanium collum plate	156
HALSTED-MOSQUITO Hemostatic forceps	51
Hand pieces	131, 160-161
HANNA Tongue spatula	96
HARALDSSON Suction elevators	44
HARTMANN (BABY-MOSQUITO) Hemostatic forceps	50
HARTMANN Tongue depressor	91
HEGAR MAYO HM Needle holders	34
Hemostatic chisels	128
Hemostatic forceps	50-51
HM Rasp	169
HM Wire cutting pliers	136
HOEFERT DENHART Mouth gag	96
Hooks	58, 60, 139



Hooks nerve	58
Hooks orbital	83
Hooks skin	60
HOSPITAL PROVIDENCE Hemostatic forceps	50
HOURIGAN Raspatories	99

I

Iliac crest curette	150
Iliac crest graft gouge	150
Iliac crest retractors	152
Inserts for angular screwdrivers	163-164
Instruments cleft palate	138-140
Instruments lip	138-140
Instruments pelvic crest	150-152
Instruments sinuslifting	141-144
Instruments wire	134-136
Interdental osteotomes	108
Intra oral retractors	81-82, 157
Irrigating instruments	39-44

J

JAEGER Lid plate	84
JANSEN ZAUFAL Bone rongeur	124
Jeweler's forceps	25, 28-29
JOSEPH Delicate dissecting scissors	13
JOSEPH Delicate retractors	61

K

KAHRE Raspatory	140
KAHRE-WILLIGER Raspatories	98
KELLY Delicate dissecting scissors	13
KELLY Hemostatic forceps	50
KILNER RAGNELL Delicate dissecting scissors	12
KILNER-DOUGHTY Tongue depressors	90-93, 138
KLUBA Orbital hooks	83
KLUBA Speculum	148
KOCHER LANGENBECK Retractors	70
KOCHER Retractors	64, 67
KOELN Mouth gag	138
KOELN Mouth gags	93-94
KOENIG Raspatory	97
KOFLER HAJEK Rongeur	125
KRETSCHMER Holders	131
KRETSCHMER Reference pin	130
KRETSCHMER Retractor	77

L

Lacrimal probes	47
LAMBOTTE MINI Osteotomes	107
LAMBOTTE Osteotomes	108
LANGENBECK Elevators	104

LANGENBECK PARKER (US ARMY) Retractor	78
LANGENBECK Retractors	66
LANGENBECK-KOCHER Retractors	70
Lid grasping forceps	24
Lid plate	84
Lid retractors	83
LINDEMANN Burrs	161
Lip instruments	138-140
Lip retractors	86-87
LISTON RUSKIN Bone cutting forceps	120
LOCKLIN Gum scissors	17
LUCAE Delicate retractors	58
LUER Bone rongeurs	122
LUNIATSCHEK Wire instruments	134

M

MACDONALD Elevators	103
MAIER Dressing forceps	54-55
Mallets	106
Mandibular rim retractor	74
MARCHAC Bone separators	117
Marking instruments	130-131
MARQUARDT Bone rongeurs	124
MATHIEU HM Needle holders	37
Maxilla mobilizer	114
MAYO Dissecting scissors	14
MAYO-HEGAR HM Needle holders	34
MAYO-STILLE Dissecting scissors	14
MCINDOE Bone cutting forceps	120
MCINDOE Dressing forceps	21
MCINDOE Raspatories	140
MCKESSON Mouth gags	89
MEAD Bone rongeurs	121
MEAD Mallets	106
Measuring instruments	129-132
MEDICON COTTLE Osteotomes	108
MERSHON Wire pusher	134
METZENBAUM BABY Delicate dissecting scissors	12
METZENBAUM-SLIM Dissecting scissors	15
MICRO 2000 Forceps	25
MICRO 2000 Needle holders	38
Micro compass saw	169
Micro forceps	25
Micro needle holders	38
Micro oscillating saw	166
Micro sagittal saw	167
Micro saws	165-171
MICRO-ADSON Dressing forceps	22
MICRO-SLIM HM Needle holders	36
MIDDELDORPF Retractors	68-69
MILLER SENN Delicate retractors	61

MINI RUSKIN Bone rongeurs	123
MINI-LAMBOTTE Osteotomes	107
Mixing cup	151
Mobilizer	114
Mobilizing retractors	116
MOD. USA Probes with eye	45
MOELTGEN Flexometer	129
MOLT Raspatory	97
MORITZ-SCHMIDT Tongue depressors	91
MOSQUITO HALSTED Hemostatic forceps	51
MOSQUITO-BABY HARTMANN Hemostatic forceps	50
Mouth gags	93-96, 138
Mucosa stretcher	80
Myrtle leaf probes	45

N

Nasal forceps	126-127
Nasal rasps	149
Nasal retractors	85
Nasal septum osteotomes	114
Nasal spine retractor	71
Needle holders	33-38
Needle holders Micro	38
NELATON Directors	46
Nerve hooks	58
Non-sticking bipolar forceps	27-32

O

OBWEGESER Alveolar retractor	74
OBWEGESER Awls	137
OBWEGESER Blade osteotomes	111
OBWEGESER Bone separator	117
OBWEGESER Channel retractors	75
OBWEGESER Chin retractor	75
OBWEGESER Fragment adapting forceps	115
OBWEGESER-FREER Elevators	103
OBWEGESER-FREER Raspatories	101
OBWEGESER-HAKIM Raspatories	158-159
OBWEGESER HM Wire twister	135
OBWEGESER Iliac crest retractors	152
OBWEGESER Interdental osteotomes	108
OBWEGESER Mandibular rim retractor	74
OBWEGESER Maxilla mobilizer	114
OBWEGESER Nasal septum osteotomes	114
OBWEGESER Nasal spine retractors	71
OBWEGESER Osteotomes	108, 110-111, 113-114
OBWEGESER Pterygoid osteotomes	113
OBWEGESER Ramus clamps	80
OBWEGESER Ramus retractors	76
OBWEGESER Raspatories	99-102

OBWEGESER Soft tissue retractors	72-73
OBWEGESER Splitting osteotomes	110
OBWEGESER Wedge osteotomes	111
OBWEGESER Wire loop forceps	135
Operating scissors	9-10
Orbital hooks	83
Osseoscalpel	168
Osteotomes	107-114
Osteotomes blade	111
Osteotomes cylinder	153
Osteotomes interdental	108
Osteotomes nasal septum	114
Osteotomes pterygoid	113
Osteotomes splitting	109-110
Osteotomes wedge	111

P

PARKER Retractors	78
PARKER-LANGENBECK (US ARMY) Retractor	78
PARTSCH Chisels	107
PASSOW Hemostatic chisels	128
Pelvic crest instruments	150-152
PEN Suction cannulas	39-41
Plate holding forceps	156
Plier flat nose	134
Pliers wire cutting	136
Positioner	115
POTTS-SMITH HM Dressing forceps	20
Probes	45-47
Probes lacrimal	47
Probes myrtle leaf	45
Probes with eye	45
PROVIDENCE-HOSPITAL Hemostatic forceps	50
Pterygoid osteotomes	113

R

RAGNELL (KILNER) Delicate dissecting scissors	12
Ramus clamps	80
Ramus retractors	76
Raspatories	97-102, 139-140, 143, 158-159
Raspatory cleft palate	139-140
Raspatory fibula	155
Rasps nasal	149
Reference pin	130
Reposition forceps	116
Retractor alveolar	74
Retractor soft tissue	72-73
Retractors	58-79
Retractors cheek	86-87



Retractors delicate	58-63
Retractors double-ended	78-79
Retractors extra oral	81
Retractors iliac crest	152
Retractors intra oral	81-82
Retractors lid	83
Retractors lip	86-87
Retractors mandibular rim	74
Retractors mobilizing	116
Retractors nasal	85
Retractors nasal spine	71
Retractors ramus	76
Retractors self-retaining	84
Retractors vein	59-60
ROEDER BACKHAUS Towel clamps	53
Rongeurs	125
Rongeurs bone	121-124
ROUX Retractors	79
ROWE Reposition forceps	116
Rulers	129, 131
RUSKIN Bone rongeurs	123-124
RUSKIN-LISTON Bone cutting forceps	120
RUSKIN-MINI Bone rongeurs	123
S	
SACHSE Micro compass saw	169
SACHSE Micro oscillating saw	166
SACHSE Micro sagittal saw	167
SACHSE Osseoscalpel	168
Saw blades	166-169
Scalpel blades	2-4
Scalpel blades mini	4
Scalpel handles	2-4, 141, 143
Scalpel handles mini	4
Scalpels	2-4
SCHEER FREER Elevator	139
SCHMIDT MORITZ Tongue depressor	91
Scissors delicate	8
Scissors dissecting	14-16
Scissors dissecting delicate	8, 11-13
Scissors gum	16-17
Scissors operating	9-10
Scissors tonsil	10
Scissors wire cutting	135
Self-retaining retractors	84
SEMB Bone holding forceps	119
SENN-MILLER Delicate retractors	61
Separators bone	117
Sharp curettes	105
SHEPARD Cortical cutter	153
SHEPARD Cross pin	153
SHEPARD Cylinder osteotomes	153

SHEPARD Rams	153
SHEPARD Trocars	153
SILVER Osteotomes	109
Sinuslifting elevators	141-142
Sinuslifting instruments	141-144
Skin hooks	60
SLIM METZENBAUM Dissecting scissors	15
SLIM MICRO HM Needle holders	36
SMITH Bone separators	117
SMITH POTTS HM Dressing forceps	20
Soft tissue retractors	72-73
Spatulas tongue	88, 96
Speculum	148
Splitting osteotomes	109-110
STEINHAEUSER Bone holding forceps	119
STEINHAEUSER Mucosa stretcher	80
STELLBRINK Bone rongeurs	122
STERNBERG Lip and cheek retractor	87
STILLE MAYO Dissecting scissors	14
STILLER Compressor	143
STILLER Raspatory	97, 141, 143
STILLER Sinuslifting elevators	141-142
STILLER Suction cannula	43, 141, 143
Suction cannulas	39-44
Suction elevator	44
Suction instruments	39-44
Surgical hand pieces	131, 160-161
T	
TAYLOR-CUSHING Bayonet forceps	26
TAYLOR-CUSHING HM Bayonet forceps	26
TESSIER Mobilizing retractors	116
TESSIER Osteotomes	112
Tissue forceps	20-23
Tissue grasping forceps	24
Titanium collum plate	156
TOBOLD Tongue depressor	91
TOENNIS-ADSON Dissecting scissors	16
Tongue depressors	90-93, 138
Tongue seizing forceps	89
Tongue spatulas	88, 96
Tonsil scissors	10
Towel clamps	52-53
Trephines	151
TRIACA Soft tissue retractors	72-73
Tungsten carbide rasp	169
Twister wire	135
U	
UNIV. MINNESOTA CAWOOD Lip and cheek retractor	87
UNIVERSAL HM Wire Cutting Scissors	135

US-ARMY PARKER-LANGENBECK Retractor	78
V	
Vein retractors	59-60
Vestibule retractors	86
VOLKMANN Retractors	64-65
VOLKMANN Sharp curettes	105
W	
WAGNER Delicate scissors	8
WALTER Lid grasping forceps	24
WANG Raspatories	140
WANGERIN Positioner	115
WASSMUND Retractor	67
Wedge osteotomes	111
WEIL-BLAKESLEY Nasal forceps	126-127
WEITLANER-WULLSTEIN Self-retaining retractors	84
WIEDER Tongue depressors	92
WILLIAMS BOWMAN Lacrimal probe	47
WILLIGER KAHRE Raspatories	98
WILLIGER Raspatories	97
Wire cutting pliers	136
Wire cutting scissors	135
Wire instruments	134-136
Wire loop forceps	135
Wire pusher	134
Wire twister	135
Wires	133
WOOD CRILE BABY HM Needle holders	35
WOOD CRILE HM Needle holders	35
WOOD CRILE Needle holders	35
WULLSTEIN WEITLANER Self-retaining retractors	84
X	
X-ray ruler	129
Y	
YOUNG Tongue seizing forceps	89
Z	
ZAUFAL-JANSEN Bone rongeur	124
Zygoma elevator	104



A	
Abrebocas	93-96, 138
Adaptador para PEN Cánulas aspiración	41
ADSON-BABY Pinzas para disección	52
ADSON Elevador	104
ADSON HM Pinza anatómica	22
ADSON Legras	98-99
ADSON MICRO Pinzas anatómicas	22
ADSON Pinza anatómica	22
ADSON TOENNIS Tijeras para disección	16
Alambres	133
Alicate plano	134
Arcos de alambre	133
AUFRICHT GUBISCH Separador nasale	85
AUFRICHT Separador nasale	85
B	
BABY ADSON Pinzas para disección	52
BABY-CRILE-WOOD HM Porta-aguja	35
BABY-METZENBAUM Tijeras finas para disección	12
BABY-MOSQUITO HARTMANN Pinzas hemostáticas	50
BACKHAUS Pinzas de campo	52-53
BACKHAUS-ROEDER Pinza de campo	53
Bajalenguas	90-93, 138
BARSKY Ganchitos para piel	60
BENICKE Separadores finos	61
BENNET Elevador	103
BEUSE Tijeras finas para disección	11
BEYER Pinzas gubias	122, 124
Bisturíes	2-4
BLAKE Mango de bisturí	2, 141, 143
BLAKESLEY WEIL Pinzas nasales	126-127
BLOCKSMA Ganchitos	139
BLUME Osteótomo	112
BLUMENTHAL Pinzas gubias	121
BOWMAN Sondas exploradoras para canal lagrimal	47
BOWMAN (WILLIAMS) Sondas exploradoras para canal lagrimal	47
BROWN Pinzas para agarrar tejidos	24
BRUENINGS Cinceles	107
BRUENINGS Espátula bucal	88
BUCHWALD Espátula bucal	88
Bulldog clamps	49
C	
Caballote para broca	151
Cables de conexión	32
Cánulas aspiración	39-44
Cánulas con oliva	42

CASTROVIEJO Compáses	132
CASTROVIEJO-EPKER Compáses	132
CAWOOD UNIV. MINNESOTA Separador de labios y mejillas	87
Cinceles	107
Cinceles para hemostasia	128
CINELLI Osteótomos	112
Clamps Bulldog	49
Clamps para el ramo	80
CLAUDINHA Espátula bucale	96
COLLIN Pinza tiralengua	89
COLLIN Separador	78
Compáses	129, 131-132
Compáses para hueso	129, 131
Compresor	143
COTTLE Elevador óseo	109
COTTLE-MEDICON Osteótomos	108
COTTLE Osteótomo	109
COTTLE Osteótomo hendedor	109
CRILE-WOOD BABY HM Porta-aguja	35
CRILE-WOOD HM Porta-agujas	35
CRILE-WOOD Porta-agujas	35
Cucharilla para la cresta ilíaca	150
Cucharillas cortantes	105
CUSHING Ganchitos para nervios	58
CUSHING Ganchos para venas	59-60
CUSHING HM Pinzas anatómicas	21
CUSHING Pinzas anatómicas/quirúrgicas	20
CUSHING (TAYLOR) HM Pinzas en forma bayoneta	26
CUSHING (TAYLOR) Pinzas en forma bayoneta	26
D	
DANDY Pinzas hemostáticas	50
DAUBENSPECK Cucharillas cortantes	105
DEAN Tijera para amígdalas	10
DEBAKEY HM Porta-agujas	35
DENHART Abreboca	96
DENHART-HOEFERT Abreboca	96
DESMARRES Separadores para párpados	83
Destornilladores de ángulo	162-164
DIEFFENBACH Clamps Bulldog	49
DINGMAN Abrebocas	95
DINGMAN Bajalenguas	92, 95
DINGMAN Elevador zigomatico	104
DINGMAN Legra	102
DINGMAN Pinzas prensoras de huesos	118
Dispositivo	32
DOCKHORN Separadores de mejillas	87
DOUGHTY-KILNER Bajalenguas	90-93, 138
DOYEN Espátulas bucales	88

E	
Elevador aspirador	44
Elevador óseo	109
Elevador zigomático	104
Elevadores	103-104, 139, 144
Elevadores para sinus-lift	141-142
EPKER CASTROVIEJO Compás	132
ERICH Arcos de alambre	133
Escofina de carburo de tungsteno	169
Espátulas bucales	88, 96
Espéculo	148
Estiletes	45-47
Estiletes con ojete	45
Estiletes hoja de mirto	45

F	
FERGUSSON-FRAZIER Cánulas aspiración	43
FOX Tijeras para encías	16
FRAZIER Cánulas aspiración	43
FRAZIER (FERGUSSON) Cánulas aspiración	43
FRAZIER Ganchito para piel	60
FREER Elevadores	103
FREER Legra	102
FREER OBWEGESER Elevador	103
FREER OBWEGESER Legras	101
FREER-SCHEER Elevador	139
Fresas	161
FROHN Porta-algodones	46

G	
Ganchitos	58, 60, 139
Ganchitos para nervios	58
Ganchitos para piel	60
Gancho de mentón	75
Ganchos para venas	59-60
GERALD Pinzas anatómicas	21
GILLIES Elevador	104
GILLIES HM Porta-aguja	36
GILLIES Pinza quirúrgica	23
GILLIES Separadores finos	60
Goniómetro	129
GROSS Pinzas para curaciones	54-55
Gubia	150
Gubia para cresta ilíaca	150
GUBISCH-AUFRIEHT Separador nasale	85
GUTHRIE Separadores finos	62

H	
HAJEK Martillo	106
HAJEK Pinzas saca-bocadas	125
HAJEK-KOFLER Pinza saca-bocada	125
HAKIM Instrumento de adaptación	158

HAKIM Legra para fibula	155
HAKIM OBWEGESER Legras	158-159
HAKIM Pinza para agarrar	159
HAKIM Pinza para agarrar placas	156
HAKIM Placa collum de titanio	156
HAKIM Separador intra oral	157
HALSTED-MOSQUITO Pinzas hemostáticas	51
HANNA Espátula bucale	96
HARALDSSON Elevadores aspiradores	44
HARTMANN (BABY-MOSQUITO) Pinzas hemostáticas	50
HARTMANN Bajalengua	91
HEGAR-MAYO HM Porta-agujas	34
HM Escofina	169
HM Pinzas para cortar alambre	136
HOEFERT DENHART Abreboca	96
Hojas de bisturí	2-4
Hojas de bisturí mini	4
Hojas de sierra	166-169
HOSPITAL PROVIDENCE Pinzas hemostáticas	50
HOURIGAN Legras	99

I	
Insertos para destornillador de ángulo	163-164
Instrumentos de lavado	39-44
Instrumento de adaptación	158
Instrumento para posicionar alambre	134
Instrumentos de aspiración	39-44
Instrumentos para alambre	134-136
Instrumentos para fisuras paladares	138-140
Instrumentos para la cresta ilíaca	150-152
Instrumentos para labios	138-140
Instrumentos para marcar	130-131
Instrumentos para medir	129-132
Instrumentos para sinus-lift	141-144

J	
JAEGER Placa para párpados	84
JANSEN ZAUFAL Pinza gubia	124
JOSEPH Separadores finos	61
JOSEPH Tijeras finas para disección	13

K	
KAHRE Legra	140
KAHRE-WILLIGER Legras	98
KELLY Pinzas hemostáticas	50
KELLY Tijeras finas para disección	13
KILNER-DOUGHTY Bajalenguas	90-93, 138
KILNER RAGNELL Tijeras finas para disección	12
KLUBA Espéculo	148
KLUBA Separadores orbitales	83



KOCHER LANGENBECK Separadores	70
KOCHER Separadores	64, 67
KOELN Abreboca	138
KOELN Abrebocas	93-94
KOENIG Legra	97
KOFLER HAJEK Pinza saca-bocada	125
KRETSCHMER Perno de referencia	130
KRETSCHMER Separador	77
KRETSCHMER Soportes	131

L

LAMBOTTE MINI Osteótomos	107
LAMBOTTE Osteótomos	108
LANGENBECK Elevadores	104
LANGENBECK Separadores	66
LANGENBECK-KOCHER Separadores	70
LANGENBECK PARKER (US ARMY) Separadores	78
Legra para fibula	155
Legra para fisura palatina	139-140
Legras	97-102, 139-140, 143, 158-159
Leznas	137
LINDEMANN Fresas	161
LISTON RUSKIN Pinzas cortantes para huesos	120
LOCKLIN Tijeras para encías	17
LUCAE Separadores finos	58
LUER Pinzas gubias	122
LUNIATSCHEK Instrumentos para alambre	134

M

MACDONALD Elevador	103
MAIER Pinzas para curaciones	54-55
Mangos de bisturí	2-4, 141, 143
Mangos de bisturí mini	4
MARCHAC Separador de hueso	117
MARQUARDT Pinzas gubias	124
Martillos	106
MATHIEU HM Porta-agujas	37
MAYO Tijeras para disección	14
MAYO-HEGAR HM Porta-agujas	34
MAYO-STILLE Tijeras para disección	14
MCINDOE Legras	140
MCINDOE Pinza anatómica	21
MCINDOE Pinza cortante para hueso	120
MCKESSON Abrebocas	89
MEAD Martillo	106
MEAD Pinzas gubias	121
MEDICON COTTLE Osteótomos	108
MERSHON Instrumento para posicionar alambre	134

METZENBAUM BABY Tijeras finas para disección	12
METZENBAUM-SLIM Tijeras para disección	15
MICRO 2000 Pinzas	25
MICRO 2000 Porta-agujas	38
Micro pinzas	25
Micro porta-agujas	38
Micro sierra de vaivén	169
Micro sierra oscilante	166
Micro sierra sagital	167
Micro sierras	165-171
MICRO-ADSON Pinzas anatómicas	22
MICRO-SLIM HM Porta-agujas	36
MIDDELDORPF Separadores	68-69
MILLER SENN Separadores finos	61
MINI RUSKIN Pinzas gubias	123
MINI-LAMBOTTE Osteótomos	107
MOD. USA Estiletes con ojete	45
MOELTGEN Goniómetro	129
Molinos de hueso	154
MOLT Legra	97
MORITZ-SCHMIDT Bajalengua	91
MOSQUITO HALSTED Pinzas hemostáticas	51
MOSQUITO-BABY HARTMANN Pinzas hemostáticas	50
Movilizador maxilar	114

N

NELATON Sondas acanaladas	46
Non-stick pinzas bipolares no adherentes	27-32

O

OBWEGESER Clamps ramus	80
OBWEGESER-FREER Elevador	103
OBWEGESER-FREER Legras	101
OBWEGESER Gancho de mentón	75
OBWEGESER-HAKIM Legras	158-159
OBWEGESER HM Pinza para torcer alambre	135
OBWEGESER Legras	99-102
OBWEGESER Leznas	137
OBWEGESER Movilizador maxilar	114
OBWEGESER Osteótomos	108, 110-111, 113-114
OBWEGESER Osteótomos de cuña	111
OBWEGESER Osteótomos de hoja	111
OBWEGESER Osteótomos hendedores	110
OBWEGESER Osteótomos interdentes	108
OBWEGESER Osteótomos para el tabique nasal	114
OBWEGESER Osteótomos pterigoideo	113
OBWEGESER Pinza para ojete de alambre	135

OBWEGESER	
Pinzas adaptadoras para fragmentos	115
OBWEGESER Separador alveolar	74
OBWEGESER	
Separador para el borde del maxilar inferior	74
OBWEGESER Separadores de hueso	117
OBWEGESER Separadores mandibulares	75
OBWEGESER Separadores para cresta ilíaca	152
OBWEGESER Separadores para el ramo	76
OBWEGESER Separadores para espina nasal	71
OBWEGESER	
Separadores para partes blandas	72-73
Osseoscalpel	168
Osteótomos	107-114
Osteótomos cilíndricos	153
Osteótomos de cuña	111
Osteótomos de hoja	111
Osteótomos hendedores	109-110
Osteótomos interdentes	108
Osteotomos para el tabique nasal	114
Osteótomos pterigoideo	113
P	
PARKER-LANGENBECK (US ARMY)	
Separadores	78
PARKER Separadores	78
PARTSCH Cinceles	107
PASSOW Cinceles para hemostasia	128
PEN Cánulas aspiración	39-41
Perno de referencia	130
Piezas de mano quirúrgicas	131, 160-161
Pinza para agarrar	159
Pinza para agarrar placas	156
Pinza para ojetes de alambre	135
Pinza para torcer alambre	135
Pinzas adaptadoras	115
Pinzas anatómicas	19-22, 54-55
Pinzas bipolares no adherentes	27-32
Pinzas cortantes para huesos	120
Pinzas de campo	52-53
Pinzas en forma bayoneta	26, 30-31
Pinzas gubias	121-124
Pinzas hemostáticas	50-51
Pinzas micro	25
Pinzas nasales	126-127
Pinzas para agarrar párpados	24
Pinzas para agarrar tejidos	24
Pinzas para cortar alambre	136
Pinzas para curaciones	54
Pinzas para disección	52
Pinzas para joyero/relojero	25, 28-29
Pinzas para reposicionar	116

Pinzas prensoras de huesos	118-119
Pinzas quirúrgicas	20-23
Pinzas saca-bocadas	125
Pinzas tiralengua	89
Pisón para huesos	128
Placa collum de titanio	156
Placa para párpados	84
Porta-agujas	33-38
Porta-agujas micro	38
Porta-algodones	46
Posicionador	115
POTTS-SMITH HM Pinzas anatómicas	20
PROVIDENCE-HOSPITAL	
Pinzas hemostáticas	50
Punzonadora cortical	153
R	
RAGNELL (KILNER)	
Tijeras finas para disección	12
Raspadores nasales	149
Regla radiografica	129
Reglas	129, 131
ROEDER BACKHAUS Pinza de campo	53
ROUX Separadores	79
ROWE Pinzas para reposicionar	116
RUSKIN Pinzas gubias	123-124
RUSKIN-LISTON	
Pinzas cortantes para huesos	120
RUSKIN-MINI Pinzas gubias	123
S	
SACHSE Micro sierra de vaivén	169
SACHSE Micro sierra oscilante	166
SACHSE Micro sierra sagital	167
SACHSE Osseoscalpel	168
SCHEER FREER Elevador	139
SCHMIDT MORITZ Bajalengua	91
SEMB Pinza prensora de hueso	119
SENN-MILLER Separadores finos	61
Separador alveolar	74
Separador para el borde del maxilar inferior	74
Separadores	58-79
Separadores autoestáticos	84
Separadores de hueso	117
Separadores de labios	86-87
Separadores de mejillas	86-87
Separadores de movilización	116
Separadores dobles	78-79
Separadores extra orales	81
Separadores finos	58-63
Separadores intra orales	81-82, 157
Separadores mandibulares	75



Separadores nasales	85
Separadores orbitales	83
Separadores para cresta ilíaca	152
Separadores para el ramo	76
Separadores para espina nasal	71
Separadores para párpados	83
Separadores para partes blandas	72-73
Separadores vestibulares	86
SHEPARD Espiga transversal	153
SHEPARD Expulsores	153
SHEPARD Osteótomos cilíndricos	153
SHEPARD Punzonadora cortical	153
SHEPARD Trocares	153
SILVER Osteótomos	109
SLIM METZENBAUM Tijeras para disección	15
SLIM MICRO HM Porta-agujas	36
SMITH POTTS HM Pinzas anatómicas	20
SMITH Separador de hueso	117
Sondas acanaladas	46
Sondas exploradoras para canal lagrimal	47
STEINHAEUSER Pinzas prensoras de huesos	119
STEINHAEUSER Tensor de mucosa	80
STELLBRINK Pinzas gubias	122
STERNBERG Separador de labios y mejillas	87
STILLE MAYO Tijeras para disección	14
STILLER Cánula aspiración	43, 141, 143
STILLER Compresor	143
STILLER Elevadores para sinus-lift	141-142
STILLER Legra	97, 141, 143
T	
TAYLOR CUSHING HM Pinzas en forma bayoneta	26
TAYLOR CUSHING Pinzas en forma bayoneta	26
Tensor de mucosa	80
TESSIER Osteótomos	112
TESSIER Separadores de movilización	116
Tijera para cortar alambre	135
Tijeras finas	8
Tijeras finas para disección	8, 11-13
Tijeras para amígdalas	10
Tijeras para disección	14-16
Tijeras para encías	16-17
Tijeras quirúrgicas	9-10
TOBOLD Bajalengua	91
TOENNIS-ADSON Tijeras para disección	16
Trépanos	151
TRIACA Separadores para partes blandas	72-73
U	
UNIV. MINNESOTA CAWOOD Separador de labios y mejillas	87

UNIVERSAL HM Tijera para cortar alambre	135
US-ARMY PARKER-LANGENBECK Separadores	78
V	
Vaso para mezclar	151
VOLKMANN Cucharillas cortantes	105
VOLKMANN Separadores	64-65
W	
WAGNER Tijeras finas	8
WALTER Pinza para agarrar párpados	24
WANG Legras	140
WANGERIN Posicionador	115
WASSMUND Separador	67
WEIL-BLAKESLEY Pinzas nasales	126-127
WEITLANER-WULLSTEIN Separadores autoestáticos	84
WIEDER Bajalenguas	92
WILLIAMS BOWMAN Sondas exploradoras para canal lagrimal	47
WILLIGER KAHRE Legras	98
WILLIGER Legras	97
WOOD CRILE BABY HM Porta-agujas	35
WOOD CRILE HM Porta-agujas	35
WOOD CRILE Porta-agujas	35
WULLSTEIN WEITLANER Separadores autoestáticos	84
Y	
YOUNG Pinza tiralengua	89
Z	
ZAUFAL-JANSEN Pinza gubia	124

A	
Abaisse-langues	90-93, 138
Adaptateur pour PEN Canules aspiration	41
ADSON-BABY Pincés à dissection	52
ADSON Elévateur	104
ADSON HM Pince anatomique	22
ADSON MICRO Pincés anatomiques	22
ADSON Pince anatomique	22
ADSON Rugines	98-99
ADSON-TOENNIS Ciseaux à dissection	16
Alènes	137
Arcs en fil	133
AUFRICHT Ecarteur nasale	85
AUFRICHT GUBISCH Ecarteur nasale	85

B	
BABY ADSON Pincés à dissection	52
BABY METZENBAUM Ciseaux délicats à dissection	12
BABY-CRILE-WOOD HM Porte-aiguille	35
BABY-MOSQUITO HARTMANN Pincés hémostatiques	50
BACKHAUS Pincés à champs	52-53
BACKHAUS-ROEDER Pince à champs	53
Bâillons	89
BARSKY Crochets à peau	60
BENICKE Ecarteurs fins	61
BENNET Elévateur	103
BEUSE Ciseaux délicats à dissection	11
BEYER Pincés-gouges	122, 124
Bistouris	2-4
BLAKE Manche pour bistouri	2, 141, 143
BLAKESLEY WEIL Pincés nasales	126-127
BLOCKSMA Crochets	139
BLUME Ostéotome	112
BLUMENTHAL Pincés-gouges	121
BOWMAN Sondes exploratrices pour le canal lacrymal	47
BOWMAN (WILLIAMS) Sondes exploratrices pour le canal lacrymal	47
BROWN Pincés pour saisir le tissu	24
BRUENINGS Ciseaux burins	107
BRUENINGS Spatule à langue	88
BUCHWALD Spatule à langue	88
Bulldog clamps	49

C	
Câbles connecteurs	32
Canules aspiration	39-44
Canules avec olive	42
CASTROVIEJO Compas	132
CASTROVIEJO-EPKER Compas	132

CAWOOD UNIV. MINNESOTA Ecarteur de lèvres et de joues	87
CINELLI Ostéotomes	112
Ciseaux à amygdales	10
Ciseaux à dissection	14-16
Ciseaux à gencive	16-17
Ciseaux burin pour hémostase	128
Ciseaux burins	107
Ciseaux chirurgicaux	9-10
Ciseaux coupe-fil	135
Ciseaux délicats	8
Ciseaux délicats à dissection	8, 11-13
Clamps à rameau	80
Clamps Bulldog	49
Clamps d'adaptation de fragments osseux	115
CLAUDINHA Spatule à langue	96
COLLIN Ecarteur	78
COLLIN Pincés tire-langue	89
Compas	129, 131-132
Compas à os	129, 131
Compresseur	143
COTTLE Levier à os	109
COTTLE-MEDICON Ostéotomes	108
COTTLE Ostéotome	109
COTTLE Ostéotome à fendre	109
CRILE-WOOD BABY HM Porte-aiguille	35
CRILE-WOOD HM Porte-aiguilles	35
CRILE-WOOD Porte-aiguilles	35
Crochets	58, 60, 139
Crochets à mobilisation	116
Crochets à nerfs	58
Crochets à peau	60
Crochets orbitaux	83
Cupule à mélange	151
Curette pour la crête iliaque	150
Curettes tranchantes	105
CUSHING Crochets à nerfs	58
CUSHING Ecarteurs à veines	59-60
CUSHING HM Pincés anatomiques	21
CUSHING Pincés anatomiques/chirurgicales	20
CUSHING (TAYLOR) HM Pincés en forme baïonnette	26
CUSHING (TAYLOR) Pincés en forme baïonnette	26

D	
DANDY Pincés hémostatiques	50
DAUBENSPECK Curettes tranchantes	105
Daviers à os	118-119
DEAN Ciseaux à amygdales	10
DEBAKEY HM Porte-aiguilles	35



DENHART Ouvre-bouche	96
DENHART-HOEFERT Ouvre-bouche	96
DESMARRES Releveurs à paupières	83
DIEFFENBACH Clamps Bulldog	49
DINGMAN Abaisse-langues	92, 95
DINGMAN Daviers à os	118
DINGMAN Elevateur zygomatique	104
DINGMAN Ouvre-bouche	95
DINGMAN Rugine	102
Dispositif	32
DOCKHORN Ecarteurs de joues	87
DOUGHTY-KILNER Abaisse-langues	90-93, 138
DOYEN Spatules à langue	88

E

Ecarteur alveolaire	74
Ecarteur pour le bord du maxillaire inférieur	74
Ecarteurs	58-79
Ecarteurs à os	117
Ecarteurs à rameau	76
Ecarteurs à veines	59-60
Ecarteurs autostatiques	84
Ecarteurs d'épine nasale	71
Ecarteurs de joues	86-87
Ecarteurs de lèvres	86-87
Ecarteurs doubles	78-79
Ecarteurs extra-oraux	81
Ecarteurs fins	58-63
Ecarteurs intra-oraux	81-82, 157
Ecarteurs mandibulaires	75
Ecarteurs nasaux	85
Ecarteurs pour la crête iliaque	152
Ecarteurs pour parties molles	72-73
Ecarteurs vestibulaires	86
Elévateur aspirateur	44
Elévateur zygomatique	104
Elévateurs	103-104, 139, 144
Elévateurs pour sinus-lift	141-142
Embouts pour le tournevis angulaire	163-164
EPKER CASTROVIEJO Compas	132
ERICH Arcs en fil	133

F

FERGUSON FRAZIER Canules aspiration	43
Fils	133
Fixe-menton	75
FOX Ciseaux à gencive	16
Fraises	161
FRAZIER Canules aspiration	43
FRAZIER Crochets à peau	60
FRAZIER (FERGUSON) Canules aspiration	43

FREER Elévateurs	103
FREER OBWEGESER Elévateurs	103
FREER OBWEGESER Rugines	101
FREER Rugines	102
FREER-SCHEER Elévateurs	139
FROHN Porte-cotons	46

G

GERALD Pincés anatomiques	21
GILLIES Ecarteurs fins	60
GILLIES Elévateurs	104
GILLIES HM Porte-aiguilles	36
GILLIES Pincés chirurgicales	23
Goniomètre	129
Gouge	150
Gouge iliaque à transplant	150
GROSS Pincés à pansements	54-55
GUBISCH-AUFRIEHT Ecarteur nasale	85
GUTHRIE Ecarteurs fins	62

H

HAJEK Maillets	106
HAJEK Pincés emporte-pièce	125
HAJEK-KOFLER Pince emporte-pièce	125
HAKIM Ecarteur intra-oral	157
HAKIM Instrument d'adaptation	158
HAKIM OBWEGESER Rugines	158-159
HAKIM Pinca à saisir	159
HAKIM Pince pour tenir les plaques	156
HAKIM Plaque collum en titane	156
HAKIM Rugine pour fibule	155
HALSTED-MOSQUITO Pincés hémostatiques	51
HANNA Spatule à langue	96
HARALDSSON Elévateurs aspirateurs	44
HARTMANN Abaisse-langues	91
HARTMANN (BABY-MOSQUITO) Pincés hémostatiques	50
HEGAR-MAYO HM Porte-aiguilles	34
HM Pincés coupe-fil	136
HM Râpe	169
HOEFERT DENHART Ouvre-bouche	96
HOSPITAL PROVIDENCE Pincés hémostatiques	50
HOURIGAN Rugines	99

I

Instrument d'adaptation	158
Instruments à irrigation	39-44
Instruments à mesurer	129-132
Instruments d'aspiration	39-44
Instruments de marquage	130-131

Instruments pour fils	134-136
Instruments pour fissures palatines	138-140
Instruments pour la crête iliaque	150-152
Instruments pour lèvres	138-140
Instruments pour sinus-lift	141-144

J

JAEGER Plaque à paupières	84
JANSEN ZAUFAL Pince-gouge	124
JOSEPH Ciseaux délicats à dissection	13
JOSEPH Ecarteurs fins	61

K

KAHRE Rugines	140
KAHRE-WILLIGER Rugines	98
KELLY Ciseaux délicats à dissection	13
KELLY Pincés hémostatiques	50
KILNER-DOUGHTY Abaisse-langue	90-93, 138
KILNER RAGNELL Ciseaux délicats à dissection	12
KLUBA Crochets orbitaux	83
KLUBA Spéculum	148
KOCHER Ecarteurs	64, 67
KOCHER LANGENBECK Ecarteurs	70
KOELN Ouvre-bouche	138
KOELN Ouvre-bouches	93-94
KOENIG Rugines	97
KOFLER HAJEK Pince emporte-pièce	125
KRETSCHMER Ecarteurs	77
KRETSCHMER Pivot de référence	130
KRETSCHMER Supports	131

L

LAMBOTTE MINI Ostéotomes	107
LAMBOTTE Ostéotomes	108
Lames de bistouris	2-4
Lames de bistouris mini	4
Lames de scie	166-169
LANGENBECK Ecarteurs	66
LANGENBECK Elévateurs	104
LANGENBECK-KOCHER Ecarteurs	70
LANGENBECK PARKER (US ARMY) Ecarteurs	78
Levier à os	109
LINDEMANN Fraises	161
LISTON RUSKIN Pincés coupantes à os	120
LOCKLIN Ciseaux à gencive	17
LUCAE Ecarteurs fins	58
LUER Pincés-gouges	122
LUNIATSCHEK Instruments pour fils	134

M

MACDONALD Elévateur	103
---------------------	-----

MAIER Pincés à pansements	54-55
Maillets	106
Manches pour bistouris	2-4, 141, 143
Manches pour bistouris mini	4
MARCHAC Ecarteur à os	117
MARQUARDT Pincés-gouges	124
MATHIEU HM Porte-aiguilles	37
MAYO Ciseaux à dissection	14
MAYO-HEGAR HM Porte-aiguilles	34
MAYO-STILLE Ciseaux à dissection	14
MCINDOE Pince anatomique	21
MCINDOE Pince coupante à os	120
MCINDOE Rugines	140
MCKESSON Baïllons	89
MEAD Maillets	106
MEAD Pincés-gouges	121
MEDICON COTTLE Ostéotomes	108
MERSHON Positionneur à fil	134
METZENBAUM BABY Ciseaux délicats à dissection	12
METZENBAUM-SLIM Ciseaux à dissection	15
MICRO 2000 Pincés	25
MICRO 2000 Porte-aiguilles	38
Micro pinzes	25
Micro porte-aiguilles	38
Micro scie à guichet	169
Micro scie oscillante	166
Micro scie sagittale	167
Micro scies	165-171
MICRO-ADSON Pincés anatomiques	22
MICRO-SLIM HM Porte-aiguilles	36
MIDDELDORPF Ecarteurs	68-69
MILLER SENN Ecarteurs fins	61
MINI RUSKIN Pincés-gouges	123
MINI-LAMBOTTE Ostéotomes	107
Mobilisateur pour maxillaire	114
MOD. USA Stylets avec chas	45
MOELTGEN Goniomètre	129
MOLT Rugine	97
MORITZ-SCHMIDT Abaisse-langue	91
MOSQUITO HALSTED Pincés hémostatiques	51
MOSQUITO-BABY HARTMANN Pincés hémostatiques	50
Moulin à os	154

N

NELATON Sondes cannelées	46
Non-stick pincés bipolaires anti-adhésives	27-32

O

OBWEGESER Alènes	137
------------------	-----



OBWEGESER Clamps à rameau	80
OBWEGESER	
Clamps d'adaptation de fragments osseux	115
OBWEGESER Ecarteur alveolaire	74
OBWEGESER	
Ecarteur pour le bord du maxillaire inférieur	74
OBWEGESER Ecarteurs à os	117
OBWEGESER Ecarteurs à rameau	76
OBWEGESER Ecarteurs d'épine nasale	71
OBWEGESER Ecarteurs iliaques	152
OBWEGESER Ecarteurs mandibulaires	75
OBWEGESER Ecarteurs pour parties molles	72-73
OBWEGESER Fixe-menton	75
OBWEGESER-FREER Elévateur	103
OBWEGESER-FREER Rugines	101
OBWEGESER-HAKIM Rugines	158-159
OBWEGESER HM Pince à torsader le fil	135
OBWEGESER Mobilisateur pour maxillaire	114
OBWEGESER Ostéotomes	108, 110-111, 113-114
OBWEGESER Ostéotomes à fendre	110
OBWEGESER Ostéotomes cunéiformes	111
OBWEGESER Ostéotomes en lame	111
OBWEGESER Ostéotomes interdentaires	108
OBWEGESER	
Ostéotomes pour cloison nasale	114
OBWEGESER Ostéotomes pterygoïdes	113
OBWEGESER Pince pour oeillets en fil métallique	135
OBWEGESER Rugines	99-102
Osséoscalpel	168
Ostéotomes	107-114
Ostéotomes à fendre	109-110
Ostéotomes cunéiformes	111
Ostéotomes cylindriques	153
Ostéotomes en lame	111
Ostéotomes interdentaires	108
Ostéotomes pour cloison nasale	114
Ostéotomes pterygoïdes	113
Ouvre-bouches	93-96, 138
P	
PARKER Ecarteurs	78
PARKER-LANGENBECK (US ARMY)	
Ecarteurs	78
PARTSCH Ciseaux burins	107
PASSOW Ciseaux burins pour hémostase	128
PEN Canules aspiration	39-41
Perforateur cortical	153
Pièces à main chirurgicales	131, 160-161
Pinca à saisir	159
Pince à saisir les paupières	24

Pince à torsader le fil	135
Pince plate	134
Pince pour oeillets en fil métallique	135
Pince pour tenir les plaques	156
Pincés à champs	52-53
Pincés à dissection	52
Pincés à pansements	54
Pincés à réposition	116
Pincés anatomiques	19-22, 54-55
Pincés bipolaires anti-adhésives	27-32
Pincés chirurgicales	20-23
Pincés coupantes à os	120
Pincés coupe-fil	136
Pincés emporte-pièce	125
Pincés en forme baïonnette	26, 30-31
Pincés hémostatiques	50-51
Pincés micro	25
Pincés nasales	126-127
Pincés pour joaillier/horloger	25, 28-29
Pincés pour saisir le tissu	24
Pincés tire-langue	89
Pincés-gouges	121-124
Pivot de référence	130
Plaque à paupières	84
Plaque collum en titane	156
Porte-aiguilles	33-38
Porte-aiguilles micro	38
Porte-cotons	46
Porte-forets	151
Positionneur	115
Positionneur à fil	134
POTTS-SMITH HM Pincés anatomiques	20
Poussoirs à os	128
PROVIDENCE-HOSPITAL	
Pincés hémostatiques	50
R	
RAGNELL (KILNER)	
Ciseaux délicats à dissection	12
Râpe en carbure de tungstène	169
Râpes nasales	149
Règle pour radiographie	129
Règles	129, 131
Releveurs à paupières	83
ROEDER BACKHAUS Pincés à champs	53
ROUX Ecarteurs	79
ROWE Pincés à réposition	116
Rugine pour fibule	155
Rugine pour fissures palatines	139-140
Rugines	97-102, 139-140, 143, 158-159
RUSKIN Pincés-gouges	123-124

RUSKIN-LISTON Pincés coupantes à os	120
RUSKIN-MINI Pincés-gouges	123
S	
SACHSE Micro scie à guichet	169
SACHSE Micro scie oscillante	166
SACHSE Micro scie sagittale	167
SACHSE Osséoscalpel	168
SCHEER FREER Elévateur	139
SCHMIDT MORITZ Abaisse-langue	91
SEMB Daviers à os	119
SENN-MILLER Ecarteurs fins	61
SHEPARD Embout transversal	153
SHEPARD Ostéotomes cylindriques	153
SHEPARD Perforateur cortical	153
SHEPARD Poussoirs	153
SHEPARD Trocart	153
SILVER Ostéotomes	109
SLIM METZENBAUM Ciseaux à dissection	15
SLIM MICRO HM Porte-aiguilles	36
SMITH Ecarteur à os	117
SMITH POTTS HM Pincés anatomiques	20
Sondes cannelées	46
Sondes exploratrices pour le canal lacrymal	47
Spatules à langue	88, 96
Spéculum	148
STEINHAEUSER Daviers à os	119
STEINHAEUSER Tendeur de muqueuse	80
STELLBRINK Pincés-gouges	122
STERNBERG Ecarteur de lèvres et de joues	87
STILLE-MAYO Ciseaux à dissection	14
STILLER Canule aspiration	43, 141, 143
STILLER Compresseur	143
STILLER Elévateurs pour sinus-lift	141-142
STILLER Rugine	97, 141, 143
Stylets	45-47
Stylets avec chas	45
Stylets feuille de myrte	45
T	
TAYLOR-CUSHING HM Pincés en forme baïonnette	26
TAYLOR-CUSHING Pincés en forme baïonnette	26
Tendeur de muqueuse	80
TESSIER Crochets à mobilisation	116
TESSIER Ostéotomes	112
TOBOLD Abaisse-langue	91
TOENNIS-ADSON Ciseaux à dissection	16
Tournevis angulaire	162-164
Tréfans	151
TRIACA Ecarteurs pour parties molles	72-73

U	
UNIV. MINNESOTA CAWOOD Ecarteur de lèvres et de joues	87
UNIVERSAL HM Ciseaux coupe-fil	135
US-ARMY PARKER-LANGENBECK Ecarteurs	78
V	
VOLKMANN Curettes tranchantes	105
VOLKMANN Ecarteurs	64-65
W	
WAGNER Ciseaux délicats	8
WALTER Pince à saisir les paupières	24
WANG Rugines	140
WANGERIN Positionneur	115
WASSMUND Ecarteur	67
WEIL-BLAKESLEY Pincés nasales	126-127
WEITLANER-WULLSTEIN Ecarteurs autostatiques	84
WIEDER Abaisse-langues	92
WILLIAMS BOWMAN Sondes exploratrices pour le canal lacrymal	47
WILLIGER KAHRE Rugines	98
WILLIGER Rugines	97
WOOD CRILE BABY HM Porte-aiguilles	35
WOOD CRILE HM Porte-aiguilles	35
WOOD CRILE Porte-aiguilles	35
WULLSTEIN WEITLANER Ecarteurs autostatiques	84
Y	
YOUNG Pince tire-langue	89
Z	
ZAUFAL-JANSEN Pince-gouge	124



A	
Abassalingua	90-93, 138
Adattatore per PEN Cannule aspirazione	41
ADSON-BABY Pinze per dissezione	52
ADSON Elevatore	104
ADSON HM Pinza anatomica	22
ADSON MICRO Pinze anatomiche	22
ADSON Periostotomi	98-99
ADSON Pinza anatomica	22
ADSON-TOENNIS Forbici per dissezione	16
Apribocca	93-96, 138
Arci di filo	133
AUFRIEHT Divaricatori nasale	85
AUFRIEHT GUBISCH Divaricatori nasale	85
B	
BABY ADSON Pinze per dissezione	52
BABY-CRILE-WOOD HM Portaghi	35
BABY-METZENBAUM Forbici delicate per dissezione	12
BABY-MOSQUITO HARTMANN Pinze emostatiche	50
BACKHAUS Pinze fissateli	52-53
BACKHAUS-ROEDER Pinza fissateli	53
BARSKY Uncini per pelle	60
BENICKE Divaricatori delicati	61
BENNET Elevatore	103
BEUSE Forbici delicate per dissezione	11
BEYER Pinze sgorbie	122, 124
Bisturi	2-4
BLAKE Manico per bisturi	2, 141, 143
BLAKESLEY WEIL Pinze nasali	126-127
BLOCKSMA Uncini	139
BLUME Osteotomo	112
BLUMENTHAL Pinze sgorbie	121
BOWMAN Sonde esploratrici per canale lacrimale	47
BOWMAN (WILLIAMS) Sonde esploratrici per canale lacrimale	47
BROWN Pinze per afferrare tessuti	24
BRUENINGS Scalpelli	107
BRUENINGS Spatola per lingua	88
BUCHWALD Spatola per lingua	88
Bulldog pinze	49
C	
Cacciaviti angolati	162-164
Cannule aspirazione	39-44
Cannule con oliva	42
CASTROVIEJO Compassi	132
CASTROVIEJO-EPKER Compassi	132
Cavi di connessione	32

CAWOOD UNIV. MINNESOTA Divaricatore di labbra e guance	87
CINELLI Osteotomi	112
CLAUDINHA Spatola per lingua	96
COLLIN Divaricatore	78
COLLIN Pinza tirlingua	89
Compassi	129, 131-132
Compasso per ossa	129, 131
Compressore	143
COTTLE Elevatore per ossa	109
COTTLE-MEDICON Osteotomi	108
COTTLE Osteotomo	109
COTTLE Osteotomo per splittaggio osseo	109
CRILE-WOOD BABY HM Portaghi	35
CRILE-WOOD HM Portaghi	35
CRILE-WOOD Portaghi	35
Cucchiai taglienti	105
Cucchiaio per la cresta iliaca	150
CUSHING Divaricatori per vene	59-60
CUSHING HM Pinze anatomiche	21
CUSHING Pinze anatomiche/chirurgiche	20
CUSHING (TAYLOR) HM Pinze a forma di baionetta	26
CUSHING (TAYLOR) Pinze a forma di baionetta	26
CUSHING Uncini per nervi	58
D	
DANDY Pinze emostatiche	50
DAUBENSPECK Cucchiai taglienti	105
DEAN Forbice per tonsille	10
DEBAKEY HM Portaghi	35
DENHART Apribocca	96
DENHART-HOEFERT Apribocca	96
DESMARRES Elevatori per palpebre	83
DIEFFENBACH Pinze Bulldog	49
DINGMAN Abassalingua	92, 95
DINGMAN Apribocca	95
DINGMAN Elevatore zigomatico	104
DINGMAN Periostotomo	102
DINGMAN Tenaglie per ossa	118
Dispositivo	32
Divaricatore per il bordo della mascella inferiore	74
Divaricatore per spina nasale	71
Divaricatori	58-79
Divaricatori autostatici	84
Divaricatori delicati	58-63
Divaricatori doppi	78-79
Divaricatori extraorali	81
Divaricatori intraorali	81-82, 157
Divaricatori nasali	85

Divaricatori osseo	117
Divaricatori per cresta iliaca	152
Divaricatori per guance	86-87
Divaricatori per labbra	86-87
Divaricatori per mobilizzazione	116
Divaricatori per ramo	76
Divaricatori per tessuti molli	72-73
Divaricatori per vene	59-60
Divaricatori vestibulari	86
DOCKHORN Divaricatori delle guance	87
DOUGHTY KILNER Abassalingua	90-93, 138
DOYEN Spatole per lingua	88

E	
Elevatore con aspirazione	44
Elevatore per ossa	109
Elevatore zigomatico	104
Elevatori	103-104, 139, 144
Elevatori per palpebre	83
Elevatori per sinus-lifting	141-142
EPKER CASTROVIEJO Compassi	132
ERICH Arci di filo	133

F	
FERGUSSON FRAZIER Cannula aspirazione	43
Fibula periostotomo	155
Fili	133
Forbice per fili d'acciaio	135
Forbici chirurgiche	9-10
Forbici delicate	8
Forbici delicate per dissezione	8, 11-13
Forbici per dissezione	14-16
Forbici per gengiva	16-17
Forbici per tonsille	10
FOX Forbici per gengiva	16
FRAZIER Cannule aspirazione	43
FRAZIER (FERGUSSON) Cannule aspirazione	43
FRAZIER Uncino per pelle	60
FREER Elevatori	103
FREER OBWEGESER Elevatori	103
FREER OBWEGESER Periostotomi	101
FREER Periostotomo	102
FREER-SCHEER Elevatore	139
Frese	161
FROHN Portacotone	46

G	
Gancio per mento	75
GERALD Pinze anatomiche	21
GILLIES Divaricatori delicati	60
GILLIES Elevatore	104
GILLIES HM Portaghi	36

GILLIES Pinza chirurgica	23
Goniometro	129
GROSS Pinze per medicazione	54-55
GUBISCH-AUFRIECHT Divaricatore nasale	85
GUTHRIE Divaricatori delicati	62

H	
HAJEK Laminotomi	125
HAJEK Martello	106
HAJEK-KOFLER Laminotomo	125
HAKIM Divaricatore intraorale	157
HAKIM Fibula periostotomi	155
HAKIM OBWEGESER Periostotomi	158-159
HAKIM Pinza da presa per placche	156
HAKIM Pinza per afferrare	159
HAKIM Placca collum in titanio	156
HAKIM Strumento per adattamento	158
HALSTED-MOSQUITO Pinze emostatiche	51
HANNA Spatola per lingua	96
HARALDSSON Elevatore aspiratore	44
HARTMANN (BABY-MOSQUITO) Pinze emostatiche	50
HARTMANN Abassalingua	91
HEGAR MAYO HM Portaghi	34
HM Pinze per tagliare fili d'acciaio	136
HM Raspa	169
HOEFERT DENHART Apribocca	96
HOSPITAL PROVIDENCE Pinze emostatiche	50
HOURIGAN Periostotomi	99

I	
Impattatori per ossa	128
Inseriti per cacciavite angolato	163-164

J	
JAEGER Piastra per palpebre	84
JANSEN ZAUFAL Pinza sgorbia	124
JOSEPH Divaricatori delicati	61
JOSEPH Forbici delicate per dissezione	13

K	
KAHRE Periostotomo	140
KAHRE-WILLIGER Periostotomi	98
KELLY Forbici delicate per dissezione	13
KELLY Pinze emostatiche	50
KILNER-DOUGHTY Abassalingua	90-93, 138
KILNER RAGNELL Forbici delicate per dissezione	12
KLUBA Retrattori orbitale	83
KLUBA Specolo	148
KOCHER Divaricatori	64, 67
KOCHER LANGENBECK Divaricatori	70



KOELN Apribocca	93-94
KOELN Apribocca	138
KOENIG Periostotomo	97
KOFLER HAJEK Laminotomo	125
KRETSCHMER Divaricatore	77
KRETSCHMER Perno di referenza	130
KRETSCHMER Sostegni	131

L

LAMBOTTE MINI Osteotomi	107
LAMBOTTE Osteotomi	108
Lame da sega	166-169
Lame per bisturi	2-4
Lame per bisturi mini	4
Laminotomi	125
LANGENBECK Divaricatori	66
LANGENBECK Elevatori	104
LANGENBECK-KOCHER Divaricatori	70
LANGENBECK PARKER (US ARMY) Divaricatori	78
LINDEMANN Frese	161
LISTON RUSKIN Pinze ossivore	120
LOCKLIN Forbici per gengiva	17
LUCAE Divaricatori delicati	58
LUER Pinze sgorbie	122
LUNIATSCHEK Strumenti per fili	134

M

MACDONALD Elevatore	103
MAIER Pinze per medicazione	54-55
Manici per bisturi	2-4, 141, 143
Manici per bisturi mini	4
Manipoli chirurgici	131, 160-161
MARCHAC Separatore osseo	117
MARQUARDT Pinze sgorbie	124
Martelli	106
MATHIEU HM Portaghi	37
MAYO Forbici per dissezione	14
MAYO-HEGAR HM Portaghi	34
MAYO-STILLE Forbici per dissezione	14
MCINDOE Periostotomi	140
MCINDOE Pinza anatomica	21
MCINDOE Pinza ossivore	120
MCKESSON Apribocca	89
MEAD Martelli	106
MEAD Pinze sgorbie	121
MEDICON COTTLE Osteotomi	108
MERSHON Posizionatore per filo	134
METZENBAUM BABY Forbici delicate per dissezione	12
METZENBAUM-SLIM Forbici per dissezione	15
MICRO 2000 Pinze	25

MICRO 2000 Portaghi	38
Micro pinze	25
Micro portaghi	38
Micro sega	169
Micro sega oscillante	166
Micro sega sagittale	167
Micro seghe	165-171
MICRO-ADSON Pinze anatomiche	22
MICRO-SLIM HM Portaghi	36
MIDDELDORPF Divaricatori	68-69
MILLER SENN Divaricatori delicati	61
MINI RUSKIN Pinze sgorbie	123
MINI-LAMBOTTE Osteotomi	107
Mobilizzatore per mascella	114
MOD. USA Specilli con ansa	45
MOELTGEN Goniometro	129
MOLT Periostotomo	97
MORITZ-SCHMIDT Abassalingua	91
MOSQUITO-BABY HARTMANN Pinze emostatiche	50
MOSQUITO HALSTED Pinze emostatiche	51
Mulini per ossa	154

N

NELATON Sonde scanalate	46
Non-stick pinze bipolari antiaderenti	27-32

O

OBWEGESER Divaricatore osseo	117
OBWEGESER Divaricatore per il bordo della mascella inferiore	74
OBWEGESER Divaricatori mandibolari	75
OBWEGESER Divaricatori per cresta iliaca	152
OBWEGESER Divaricatori per ramo	76
OBWEGESER Divaricatori per spina nasale	71
OBWEGESER Divaricatori per tessuti molli	72-73
OBWEGESER-FREER Elevatori	103
OBWEGESER-FREER Periostotomi	101
OBWEGESER Gancio per mento	75
OBWEGESER-HAKIM Periostotomi	158-159
OBWEGESER HM Pinza per torcere fili	135
OBWEGESER Mobilizzatore per mascella	114
OBWEGESER Osteotomi	108, 110-111, 113-114
OBWEGESER Osteotomi a forma di cuneo	111
OBWEGESER Osteotomi a forma di lama	111
OBWEGESER Osteotomi interdentali	108
OBWEGESER Osteotomi per setto nasale	114
OBWEGESER Osteotomi per splittaggio osseo	110
OBWEGESER Osteotomi pterigoidei	113
OBWEGESER Periostotomi	99-102
OBWEGESER Pinza occhiello per filo metallico	135

OBWEGESER Pinze per avvicinare frammenti	115
OBWEGESER Pinze per ramus	80
OBWEGESER Punteruoli	137
OBWEGESER Uncino alveolare	74
Osseoscalpello	168
Osteotomi	107-114
Osteotomi a forma di cuneo	111
Osteotomi a forma di lama	111
Osteotomi cilindrici	153
Osteotomi interdentali	108
Osteotomi per setto nasale	114
Osteotomi per splittaggio osseo	109-110
Osteotomi pterigoidei	113
P	
PARKER Divaricatori	78
PARKER-LANGENBECK (US ARMY) Divaricatori	78
PARTSCH Scalpelli	107
PASSOW Scalpelli per emostasi	128
PEN Cannule aspirazione	39-41
Perforatore corticale	153
Periostotomi	97-102, 139-140, 143, 158-159
Periostotomi per fessura del palato	139-140
Perno di referenza	130
Piastra per palpebre	84
Pinza da presa per placche	156
Pinza occhiello per filo metallico	135
Pinza per afferrare	159
Pinza per torcere fili	135
Pinze a forma di baionetta	26, 30-31
Pinze anatomiche	19-22, 54-55
Pinze bipolari antiaderenti	27-32
Pinze Bulldog	49
Pinze chirurgiche	20-23
Pinze d'addattamento	115
Pinze emostatiche	50-51
Pinze fissateli	52-53
Pinze micro	25
Pinze nasali	126-127
Pinze ossivore	120
Pinze per afferrare palpebre	24
Pinze per afferrare tessuti	24
Pinze per avvicinare frammenti	115
Pinze per dissezione	52
Pinze per gioielliere/orologioiaio	25, 28-29
Pinze per medicazione	54
Pinze per ramo	80
Pinze per riposizione	116
Pinze per tagliare fili d'acciaio	136
Pinze sgorbie	121-124

Pinze tirlingua	89
Placca collum in titanio	156
Portacotone	46
Portaghi	33-38
Portaghi micro	38
Posizionatore	115
Posizionatore per filo	134
POTTS-SMITH HM Pinze anatomiche	20
PROVIDENCE-HOSPITAL Pinze emostatiche	50
Punteruoli	137

R	
RAGNELL (KILNER) Forbici delicate per dissezione	12
Raspa in carburo di tungsteno	169
Raspe nasali	149
Retrattori orbitale	83
Righelli	129, 131
Righello per radiografia	129
ROEDER BACKHAUS Pinza fissateli	53
ROUX Divaricatori	79
ROWE Pinze per riposizione	116
RUSKIN Pinze sgorbie	123-124
RUSKIN-LISTON Pinze ossivore	120
RUSKIN-MINI Pinze sgorbie	123

S	
SACHSE Micro sega	169
SACHSE Micro sega oscillante	166
SACHSE Micro sega sagittale	167
SACHSE Osseoscalpello	168
Scalpelli	107
Scalpelli per emostasi	128
SCHEER FREER Elevatore	139
SCHMIDT MORITZ Abassalingua	91
Scodella per miscelare	151
SEMB Tenaglie per ossa	119
SENN-MILLER Divaricatori delicati	61
Separatori mandibolari	75
Sgorbia	150
Sgorbia per cresta iliaca	150
SHEPARD Espulsori	153
SHEPARD Osteotomi cilindrici	153
SHEPARD Perforatore corticale	153
SHEPARD Perno trasversale	153
SHEPARD Trocar	153
SILVER Osteotomi	109
SLIM METZENBAUM Forbici per dissezione	15
SLIM MICRO HM Portaghi	36
SMITH POTTS HM Pinze anatomiche	20
SMITH Separatore osseo	117
Sonde esploratrici per canale lacrimale	47



Spatole per lingua	88, 96
Specilli	45-47
Specilli a foglia di mirto	45
Specilli con ansa	45
Specilli scanalati	46
Specolo	148
STEINHAEUSER Tenaglie per ossa	119
STEINHAEUSER Tenditore di mucosa	80
STELLBRINK Pinze sgorbie	122
STERNBERG Divaricatore di labbra e guance	87
STILLE MAYO Forbici per dissezione	14
STILLER Cannula aspirazione	43, 141, 143
STILLER Compressore	143
STILLER Elevatori per sinus-lifting	141-142
STILLER Periostotomo	97, 141, 143
Strumenti per aspirazione	39-44
Strumenti per fessure del palato	138-140
Strumenti per fili	134-136
Strumenti per la cresta iliaca	150-152
Strumenti per labbra	138-140
Strumenti per lavaggio	39-44
Strumenti per marcare	130-131
Strumenti per misurare	129-132
Strumenti per sinus-lifting	141-144
Strumento per adattamento	158
Supporto perforatori	151
T	
TAYLOR CUSHING HM Pinze a forma di baionetta	26
TAYLOR CUSHING Pinze a forma di baionetta	26
Tenaglia piatta	134
Tenaglie per ossa	118-119
Tenditore di mucosa	80
TESSIER Divaricatori per mobilizzazione	116
TESSIER Osteotomi	112
TOBOLD Abassalingua	91
TOENNIS-ADSON Forbici per dissezione	16
Trapani	151
TRIACA Divaricatori per tessuti molli	72-73
U	
Uncini	58, 60, 139
Uncini per nervi	58
Uncini per pelle	60
Uncino alveolare	74
UNIV. MINNESOTA CAWOOD Divaricatore di labbra e guance	87
UNIVERSAL HM Forbice per fili d'acciaio	135
US-ARMY PARKER-LANGENBECK Divaricatori	78

V	
VOLKMANN Cucchiai taglienti	105
VOLKMANN Divaricatori	64-65
W	
WAGNER Forbice delicata	8
WALTER Pinza per afferrare palpebre	24
WANG Periostotomi	140
WANGERIN Posizionatore	115
WASSMUND Divaricatore	67
WEIL-BLAKESLEY Pinze nasali	126-127
WEITLANER-WULLSTEIN Divaricatori autostatici	84
WIEDER Abassalingua	92
WILLIAMS BOWMAN Sonde esploratrici per canale lacrimale	47
WILLIGER KAHRE Periostotomi	98
WILLIGER Periostotomi	97
WOOD CRILE BABY HM Portaghi	35
WOOD CRILE HM Portaghi	35
WOOD CRILE Portaghi	35
WULLSTEIN WEITLANER Divaricatori autostatici	84
Y	
YOUNG Pinze tirlingua	89
Z	
ZAUFAL-JANSEN Pinza sgorbia	124

MEDICON

instruments

OMF - SURGERY

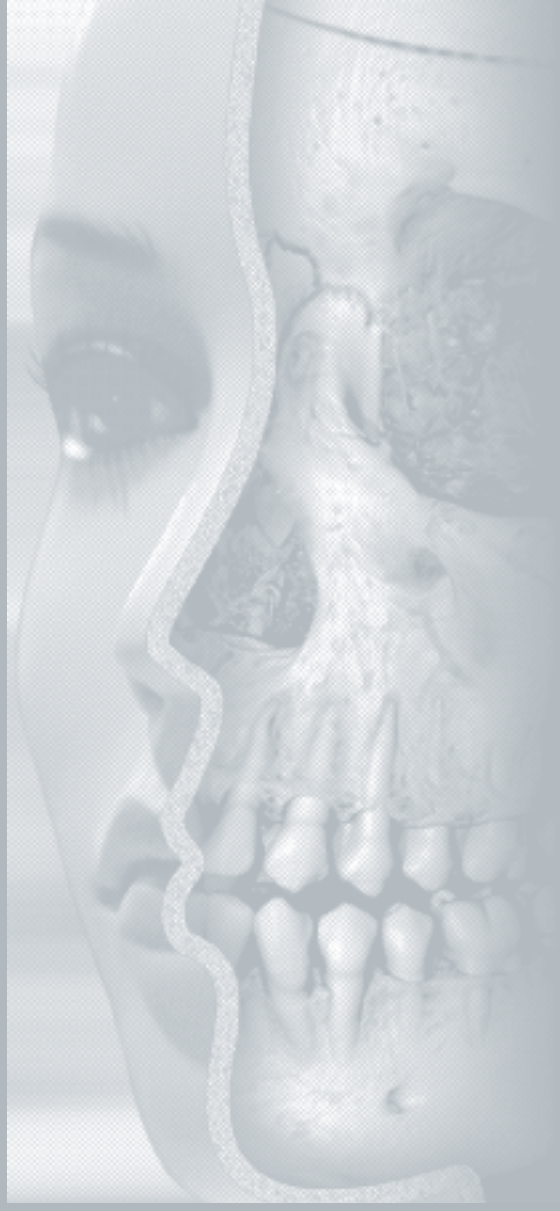



NUMERICAL INDEX



E06

Numerischer Index
Numerical Index
Indice numérico
Index numérique
Indice numerico

01.22.10	2	03.50.64	14	06.02.11	19	07.60.07	25
01.22.11	2	03.51.14	14	06.02.13	19	07.64.03	25
01.22.12	2	03.51.64	14	06.02.14	19	07.64.04	25
01.22.15	2	03.56.15	14	06.02.15	19	07.64.13	25
01.22.18	3	03.56.65	14	06.02.16	19	07.64.14	25
01.22.19	3	03.57.15	14	06.02.18	19	09.08.13	45
01.22.20	3	03.57.65	14	06.03.65	20	09.08.14	45
01.22.21	3	04.13.13	12	06.03.68	20	09.08.16	45
01.22.22	3	04.13.15	12	06.03.73	20	09.08.20	45
01.22.23	3	04.13.63	12	06.10.13	23	09.10.13	45
01.22.24	3	04.13.65	12	06.10.14	23	09.10.14	45
01.22.25	3	04.32.11	12	06.10.16	23	09.10.16	45
01.27.03	2	04.32.61	12	06.10.18	23	09.10.20	45
01.27.07	2	04.33.11	12	06.10.20	23	09.11.13	45
01.27.13	2	04.33.61	12	06.11.13	23	09.11.14	45
01.27.17	2	04.34.14	15	06.11.14	23	09.11.15	45
01.27.23	2	04.34.18	15	06.11.16	23	09.11.18	45
01.27.40	2	04.34.20	15	06.11.20	23	09.11.20	45
01.28.04	3	04.34.64	15	06.11.84	23	09.15.11	46
01.28.14	3	04.34.68	15	06.11.86	23	09.15.14	46
01.28.24	3	04.34.70	15	06.20.12	22	09.15.16	46
01.30.32	4	04.35.14	15	06.20.62	22	09.15.18	46
01.30.36	4	04.35.18	15	06.21.62	22	09.15.20	46
01.30.38	2, 143	04.35.20	15	06.22.12	22	09.16.66	46
01.30.65	4	04.35.64	15	06.22.15	22	09.20.12	46
01.30.67	4	04.35.68	15	06.23.12	22	09.20.14	46
02.06.12	8	04.35.70	15	06.23.15	22	09.20.16	46
02.07.12	8	04.50.15	13	06.40.15	21	09.79.70	42
02.26.12	8	04.51.15	13	06.40.85	23	09.79.71	42
02.27.12	8	04.54.16	13	06.60.17	20	09.79.72	42
02.40.12	11	04.54.66	13	06.60.18	20	09.79.73	42
02.40.62	11	04.55.16	13	06.60.68	21	09.79.74	42
02.41.12	11	04.55.66	13	06.60.69	21	09.79.75	42
02.41.62	11	04.63.18	16	06.60.87	20	09.79.76	42
02.70.14	11	04.63.68	16	06.60.88	20	09.79.85	42
02.71.14	11	04.80.13	16	06.60.90	21	09.83.07	43, 143
03.02.14	9	04.80.63	16	06.60.91	21	09.83.56	43
03.02.64	9	04.81.13	16	06.60.92	21	09.83.58	43
03.03.14	9	04.81.63	16	06.60.93	21	09.83.60	43
03.03.64	9	04.83.16	17	07.10.15	24	09.83.62	43
03.04.14	9	04.83.17	17	07.10.20	24	09.83.73	43
03.04.64	9	04.83.26	17	07.10.25	24	09.83.76	43
03.05.14	9	04.83.27	17	07.26.18	26	09.83.78	43
03.05.64	9	06.00.11	19	07.26.19	26	09.83.80	43
03.06.14	10	06.00.13	19	07.26.68	26	09.83.82	43
03.06.64	10	06.00.14	19	07.27.18	26	09.99.01	40
03.07.14	10	06.00.15	19	07.60.03	25	09.99.03	41
03.07.64	10	06.00.16	19	07.60.04	25	09.99.07	40
03.50.14	14	06.00.18	19	07.60.05	25	09.99.08	40

09.99.09	40	14.30.11	136	20.17.08	59	20.67.02	63
09.99.11	40	14.30.13	136	20.17.10	59	20.67.03	63
09.99.12	40	14.30.17	136	20.17.12	59	20.67.04	63
09.99.13	40	14.46.14	134	20.17.14	59	22.12.15	78
10.18.65	34	15.10.38	49	20.17.16	59	22.14.13	78
10.18.68	34	15.10.51	49	20.17.18	59	22.14.18	78
10.18.70	34	15.11.38	49	20.17.28	59	22.16.00	79
10.18.73	34	15.11.51	49	20.17.30	59	22.16.14	79
10.18.74	34	15.12.35	49	20.17.32	59	22.16.15	79
10.18.76	34	15.12.55	49	20.17.34	59	22.16.16	79
10.18.80	34	15.13.35	49	20.17.36	59	22.18.21	78
10.18.85	34	15.13.55	49	20.17.38	59	22.30.02	65
10.18.88	34	15.32.09	50	20.17.50	60	22.30.03	65
10.18.90	34	15.33.09	50	20.22.01	58	22.30.04	65
10.18.93	34	15.44.12	51	20.22.02	58	22.31.02	65
10.20.15	35	15.44.14	51	20.22.03	58	22.31.03	65
10.20.18	35	15.44.32	51	20.22.31	58	22.31.04	65
10.20.20	35	15.45.12	51	20.22.32	58	22.34.01	64
10.20.23	35	15.45.14	51	20.22.36	58	22.34.51	64
10.20.64	35	15.45.32	51	20.22.37	58	22.35.01	64
10.20.65	35	15.46.12	51	20.30.12	60	22.42.01	64
10.20.68	35	15.46.32	51	20.30.19	60	22.43.01	64
10.20.70	35	15.47.12	51	20.30.20	60	23.05.10	66
10.20.73	35	15.47.32	51	20.35.01	60	23.05.14	66
10.20.75	35	15.50.14	50	20.35.02	60	23.05.16	66
10.20.76	35	15.51.14	50	20.48.10	61	23.20.11	66
10.20.80	35	15.70.14	50	20.48.11	61	23.20.12	66
10.24.65	36	15.71.14	50	20.50.02	61	23.20.13	66
10.24.66	36	16.11.84	50	20.50.05	61	23.21.01	67
10.24.68	36	16.11.94	50	20.50.07	61	23.21.02	67
10.24.69	36	17.05.14	52	20.50.10	61	23.25.01	70
10.24.70	36	17.05.19	52	20.52.10	62	23.25.02	70
10.24.71	36	17.55.08	52	20.52.11	62	23.25.03	70
10.24.73	36	17.55.10	52	20.53.42	62	23.25.04	70
10.59.65	36	17.55.13	52	20.53.43	62	23.25.05	70
11.20.64	37	17.55.15	52	20.53.50	62	23.25.06	70
11.20.67	37	17.55.20	53	20.64.01	63	23.25.07	70
11.20.70	37	17.55.23	53	20.64.02	63	23.25.08	70
11.20.74	37	17.55.83	53	20.64.03	63	23.25.09	70
11.22.64	37	19.14.20	54	20.64.04	63	23.25.10	70
11.22.67	37	19.14.26	54	20.65.01	63	23.25.11	70
11.22.70	37	19.15.20	54	20.65.02	63	23.25.12	70
12.18.66	38	19.15.26	54	20.65.03	63	23.25.13	70
12.18.67	38	19.16.20	55	20.65.04	63	23.25.14	70
12.18.68	38	19.16.26	55	20.66.01	63	23.33.01	68
12.18.69	38	19.17.20	55	20.66.02	63	23.33.02	68
12.18.74	38	19.17.26	55	20.66.03	63	23.33.03	68
12.18.75	38	20.05.08	61	20.66.04	63	23.33.11	69
14.23.62	135	20.05.09	61	20.67.01	63	22.33.12	69



E06

Numerischer Index
Numerical Index
Indice numérico
Index numérique
Indice numerico

23.33.13	69	27.64.07	108	30.30.15	122	46.35.22	151
24.26.13	84	27.64.09	108	30.30.35	122	47.50.60	151
24.26.14	84	27.64.12	108	30.71.02	122	60.00.40	132
26.29.07	104	27.92.04	107	30.71.03	122	60.00.41	132
26.29.10	104	27.92.06	107	30.76.17	122	60.00.42	132
26.35.00	139	27.92.08	107	30.76.18	122	60.00.43	132
26.35.01	102	27.92.10	107	31.04.02	123	60.05.10	83
26.35.02	103	27.95.03	128	31.04.03	123	60.05.11	83
26.35.03	103	27.95.05	128	31.05.02	123	60.05.12	83
26.37.07	97	27.95.07	128	31.05.03	123	60.05.13	83
26.37.08	97, 143	27.95.09	128	31.06.05	124	60.05.14	83
26.37.12	103	27.95.11	128	31.06.25	123	60.05.95	84
26.37.90	103	27.95.12	128	31.07.05	124	60.34.10	47
26.40.06	97	28.62.26	150	31.07.25	123	60.34.11	47
26.42.03	97	28.62.26P	150	31.11.04	124	60.34.12	47
26.42.05	97	28.94.04	108	31.11.05	124	60.34.14	47
26.42.06	98	28.94.06	108	31.11.13	124	60.34.16	47
26.42.07	97	28.94.08	108	33.56.18	120	60.34.18	47
26.42.08	98	28.94.10	108	33.57.18	120	60.34.31	47
26.42.14	98	28.94.12	108	33.59.17	120	60.34.32	47
26.42.15	98	28.94.15	108	35.11.13	118	60.34.34	47
26.42.56	98	28.94.20	108	35.11.14	118	60.34.36	47
26.42.58	98	28.94.25	108	35.15.18	118	60.34.38	47
26.48.01	98	28.94.30	108	35.15.19	118	60.55.40	24
26.48.02	104	28.94.40	108	35.20.20	119	63.45.07	131, 160
26.48.03	99	28.94.44	108	35.24.20	119	63.45.11	131, 161
26.48.04	99	28.94.50	108	44.37.15	129	63.45.13	131, 161
27.04.20	106	29.51.24	105	44.37.20	129, 131	63.45.15	161
27.06.20	106	29.51.33	105	44.37.30	129	63.45.44	131, 160
27.06.21	106	29.51.42	105	44.37.50	129	63.45.48	160
27.06.30	106	29.51.50	105	44.37.95	129	63.90.70	151
27.06.31	106	29.51.51	105	44.38.10	129	63.90.80	151
27.10.31	106	29.51.52	105	44.38.40	129, 131	66.01.20	148
27.10.32	106	29.51.53	105	45.51.31	90	66.28.01	126
27.10.33	106	29.51.54	105	45.51.32	90	66.28.02	126
27.57.02	107	29.51.55	105	45.51.33	90	66.28.03	126
27.57.04	107	29.51.56	105	45.51.34	90	66.28.04	126
27.57.06	107	29.51.60	150	45.51.35	90	66.28.05	126
27.57.08	107	29.68.42	105	45.52.30	94, 138	66.28.11	126
27.57.10	107	29.68.50	105	45.52.31	94, 138	66.28.12	126
27.57.12	107	29.68.51	105	45.57.11	90, 94, 138	66.28.13	126
27.57.15	107	29.68.52	105	45.57.12	90	66.28.14	126
27.57.90	107	30.07.14	121	45.57.13	90	66.28.31	126
27.61.02	107	30.07.15	121	45.57.14	90	66.28.32	126
27.61.03	107	30.15.14	121	45.57.15	90	66.28.33	126
27.61.04	107	30.15.17	121	45.57.17	89	66.28.34	126
27.61.06	107	30.25.30	121	45.81.17	89	66.28.71	127
27.61.08	107	30.25.45	121	45.82.16	89	66.28.72	127
27.64.04	108	30.25.90	121	45.82.17	89	66.28.73	127

66.28.74	127	68.01.44	73	68.03.04	108	68.06.15	73
66.28.75	127	68.01.45	73	68.03.07	110	68.06.16	73
66.28.81	127	68.01.46	73	68.03.07P	110	68.07.10	159
66.28.82	127	68.01.47	73	68.03.10	110	68.07.11	158
66.28.83	127	68.01.53	74	68.03.10P	110	68.07.12	158
66.28.84	127	68.01.56	76	68.03.12	111	68.07.15	157
66.38.10	125	68.01.57	76	68.03.12P	111	68.07.18	159
66.38.21	125	68.01.63	74	68.03.13	111	68.07.23	158
66.38.22	125	68.01.65	71	68.03.13P	111	68.07.24	156
66.38.31	125	68.01.67	152	68.03.14	111	68.09.05	102
66.38.32	125	68.01.68	152	68.03.14P	111	68.09.20	104
67.15.98	44	68.01.72	80	68.03.16	111	68.15.05	133
67.21.32	85	68.01.73	80	68.03.16P	111	68.15.10	133
67.21.33	85	68.01.80	75	68.03.17	111	68.15.50	134
67.21.35	85	68.01.81	75	68.03.17P	111	68.18.91	67
67.32.80	109	68.01.82	75	68.03.18	111	68.18.92	87
67.37.10	112	68.01.97	86	68.03.18P	111	68.18.93	87
67.37.12	112	68.01.98	86	68.03.19	111	68.24.00	166
67.37.14	112	68.01.99	86	68.03.19P	111	68.24.01	166
67.37.16	112	68.02.00	99	68.03.29	114	68.24.02	167
67.37.20	112	68.02.01	99	68.03.30	113	68.24.03	167
67.38.10	109	68.02.02	99	68.03.31	113	68.24.05	168
67.38.11	109	68.02.03	99	68.03.32	113	68.24.06	168
67.38.12	109	68.02.04	99	68.03.34	113	68.24.10	169
67.61.00	149	68.02.06	100	68.03.35	113	68.24.11	169
67.61.01	149	68.02.07	100	68.03.39	108	68.24.12	169
67.61.03	149	68.02.08	100	68.03.50	112	68.24.13	169
67.61.10	149	68.02.09	100	68.03.51	112	68.24.14	169
67.61.11	149	68.02.11	101	68.03.52	112	68.24.15	169
67.61.12	149	68.02.12	101	68.03.53	112	68.24.16	169
67.61.13	149	68.02.13	101	68.03.71	114	68.24.19	166-169
67.61.14	149	68.02.19	103	68.03.72	114	68.24.20	166-169
67.61.15	149	68.02.20	101	68.03.73	114	68.24.21	169
67.61.16	149	68.02.21	101	68.03.76	114	68.24.22	169
67.61.17	149	68.02.22	101	68.04.05	137	68.24.24	166
67.61.18	149	68.02.24	102	68.04.10	137	68.24.25	166
67.61.19	149	68.02.25	102	68.04.15	137	68.24.26	166
68.01.20	71	68.02.31	102	68.04.73	135	68.24.27	166
68.01.25	76	68.02.33	102	68.04.76	135	68.24.28	166
68.01.31	72	68.02.40	155	68.05.20	115	68.24.29	166
68.01.32	72	68.02.69	81	68.05.30	77	68.24.30	166
68.01.33	72	68.02.70	81	68.06.02	72	68.24.31	166
68.01.34	72	68.02.73	81	68.06.03	72	68.24.35	168
68.01.35	72	68.02.74	81	68.06.04	72	68.24.36	168
68.01.36	72	68.02.75	82	68.06.05	72	68.24.37	168
68.01.37	72	68.02.76	82	68.06.07	72	68.24.70	167
68.01.41	73	68.02.77	82	68.06.11	73	68.24.71	167
68.01.42	73	68.02.78	82	68.06.12	73	68.24.72	167
68.01.43	73	68.03.02	108	68.06.14	73	68.24.73	167



E06

Numerischer Index
Numerical Index
Indice numérico
Index numérique
Indice numerico

68.24.74	167	68.82.12	139	72.08.13	92, 94-95, 138	88.08.01	30
68.24.75	167	68.82.20	140			88.08.02	30
68.25.20	80	68.82.25	140	72.08.14	93	88.08.03	30
68.25.21	80	68.82.27	140	72.08.15	93	88.08.04	30
68.25.88	119	68.82.31	83	72.08.20	95	88.08.05	30
68.25.89	119	68.82.32	83	72.10.01	89	88.08.06	30
68.30.01	162	68.82.33	83	72.10.02	89	88.08.07	30
68.30.05	162	68.82.49	144	72.10.03	89	88.08.08	30
68.30.06	163	68.82.50	144	72.45.50	10	88.08.09	30
68.30.07	163	68.82.51	144	76.01.03	133	88.08.10	30
68.30.08	163	68.82.53	142	76.01.04	133	88.08.11	30
68.30.10	162	68.82.54	142	76.01.05	133	88.08.12	30
68.30.18	163	68.82.55	142	78.41.02	153	88.08.13	30
68.30.19	163	68.82.56	142	78.41.05	153	88.08.14	30
68.30.20	163	68.82.57	142	78.41.06	153	88.08.15	30
68.30.21	163	68.82.58	143	78.41.08	153	88.08.71	31
68.30.34	164	68.82.75	154	78.41.11	153	88.08.72	31
68.30.36	164	68.82.76	154	78.41.12	153	88.08.73	31
68.30.37	164	68.82.81	140	78.41.13	153	88.08.76	31
68.30.38	164	68.82.82	140	78.41.14	153	88.08.77	31
68.30.39	164	68.82.83	140	78.41.15	153	88.08.81	31
68.30.48	164	68.82.84	140	78.41.16	153	88.08.82	31
68.30.49	164	68.84.00	130	78.41.18	153	88.08.91	31
68.30.50	164	68.84.04	131	88.00.20	32	88.08.92	31
68.30.51	164	68.84.05	131	88.00.21	32	88.08.93	31
68.30.52	164	68.84.06	131	88.00.22	32	202.40.12	11
68.30.53	164	72.00.01	88	88.00.23	32	202.40.62	11
68.40.01	115	72.00.10	88	88.00.24	32	202.41.12	11
68.40.02	115	72.00.15	88	88.00.27	32	202.41.62	11
68.40.04	117	72.00.18	88	88.00.40	32	203.02.14	9
68.40.08	117	72.00.27	88	88.07.02	28	203.03.14	9
68.40.10	117	72.00.28	88	88.07.03	28	203.04.14	9
68.45.10	104	72.00.50	88	88.07.07	28	203.05.14	9
68.50.01	116	72.00.52	96	88.07.08	28	203.06.14	10
68.50.02	116	72.00.56	96	88.07.12	28	203.07.14	10
68.50.03	116	72.00.85	91	88.07.13	28	203.50.14	14
68.50.04	116	72.01.15	91	88.07.14	28	203.50.64	14
68.51.01	116	72.01.25	91	88.07.15	28	203.51.14	14
68.51.02	116	72.01.40	92	88.07.20	29	203.51.64	14
68.61.01	161	72.01.41	92	88.07.23	29	203.56.15	14
68.61.02	161	72.02.10	87	88.07.56	29	203.56.65	14
68.61.03	161	72.02.15	87	88.07.57	29	203.57.15	14
68.61.05	161	72.05.61	96	88.07.58	29	203.57.65	14
68.61.06	161	72.05.63	96	88.07.81	28	204.13.13	12
68.70.82	156	72.08.00	95	88.07.82	28	204.13.15	12
68.70.82A	156	72.08.11	92, 94-95, 138	88.07.83	28	204.13.63	12
68.81.31	139			88.07.91	29	204.13.65	12
68.81.32	139	72.08.12	92, 94-95, 138	88.07.92	29	204.32.11	12
68.82.11	139			88.07.93	29	204.32.61	12

||| CMF

||| SURGICAL

||| NEURO+SPINE



Medicon eG

Gänsäcker 15
D-78532 Tuttlingen

P. O. Box 44 55
D-78509 Tuttlingen

Tel.: +49 (0) 74 62 / 20 09-0
Fax: +49 (0) 74 62 / 20 09-50

E-Mail: sales@medicon.de
Internet: www.medicon.de

Germany

450.00.62

medicon[®]

||| CMF

